

Hydraulikk as



kNm Hydraulikk AS
Skvadronvegen 27
4050 Sola

post@knm-hydraulikk.no
www.knm-hydraulikk.no

RENTAL CATALOG

SAFETY **STARTS WITH KNOWLEDGE**

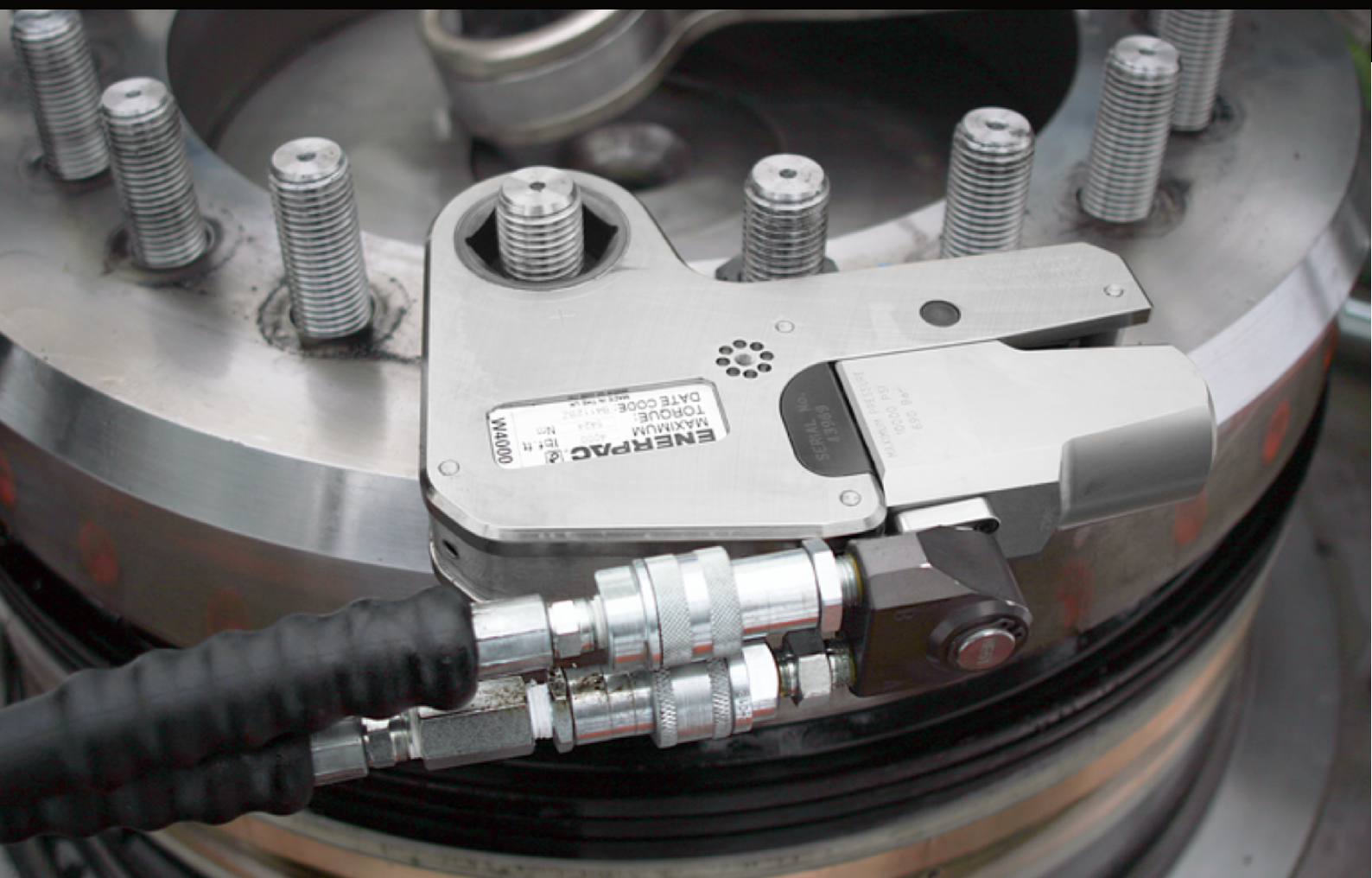

ABOUT US

kNm Hydraulikk have over 25 years experience with the design, sale and rental of tools and known for being an experienced and knowledgeable supplier of products and services within bolt tension and flange-work. Our expertly trained staff coupled with our extensive product portfolio puts us in a strong position to solve our clients bolting, flange work and hydraulic needs.

We are a certified Enerpac-Hydratight supplier and offer their torque tools, tensioner tools and standard hydraulics for both sale and rental. The products we offer are innovative and market leaders within their field.

kNm Hydraulikk put their customer first and can offer a vast array of technical support services from calibration, services and repairs.

OUR KNOWLEDGE - YOUR SAFETY is a slogan we stand for. We aim to build relationships that last and willing to go the extra mile to ensure client satisfaction and this is evident as the majority of our clients have been with us long term.



CONTENTS

Torque Tools	6 - 9
Impact Sockets	10
Pneumatic & Cordless Tools	11 - 13
Torque Wrenches	14 - 18
Safety Tools	19 - 20
Torque Pumps- Air Driven	21 - 22
Torque Pumps- Electric.....	23 - 24
Tensioners	25 - 26

WHAT WE OFFER

- HIGH LEVEL OF CUSTOMER SERVICE
- FULLY SERVICED, CALIBRATED AND CERTIFIED EQUIPMENT
- INNOVATIVE & HIGH QUALITY EQUIPMENT
- TAILORED RENTAL PACKAGES
- FLEXIBLE HIRE PERIODS
- SAME DAY DELIVERY
- LARGE RENTAL FLEET
- NO MINIMUM HIRE PERIODS
- TRAINING FROM OUR EXPERIENCED STAFF
- COURSES & TRAINING IN FLANGEWORK (NS-EN 1591-4)

Tensioner Pumps	27 - 28
Industrial Cutters	29 - 31
Flange Spreading Tools	32 - 37
Cylinders	38 - 39
Hand Pumps	40
Components – Hoses	41 - 42
Components – Gauges.....	43 - 44
Components – Manifolds	45 - 46



Our Rental Park



The rental park we have available enables us to cover several clients simultaneously. The equipment is used offshore on a daily basis and has been developed over a long period of time to withstand the harsh environment that we have on the Norwegian Continental Shelf.

We have a large selection of tools in our rental park that facilitate work with the assembly, disassembly and maintenance of flanges and bolts. For assembly work and maintenance of flanges, we offer the Enerpac Equalizer range of mechanical and hydraulic flange spreaders and flange adjustment tools. When it comes to subsea bolting and tensioning, it is very important that the equipment being used is easy to operate by divers. Through our partner Enerpac Hydratight we offer most dimensions within subsea tensioning equipment for rental.

kNm Hydraulikk has developed a number of products within HSE that can be made available for rental. When using hydraulic torque wrenches, falling objects and injuries are the greatest potential dangers within the field. In our rental park, we offer equipment for various HSE needs, such as safety wrenches and equipment for bolt tightening, preventing dangers such as falling objects and crush injuries. We also offer manually calibrated torque wrenches for rental for smaller bolt dimensions.

Why Rent Tools?

Tight project **timeline** & budget

When budget and project schedule is tight, it is often easier and faster to approve a weekly or monthly tool rental expense within a operating budget.

Asset management **burden**?

The ability to store, repair, insure and manage inventory is not an option for all companies. Many businesses prefer kNm Hydraulikk to carry the burden of owning assets

Rare & **specialized** tools?

Determining whether the tools can be used again in the future (and how often) has a significant impact on the financial comparison. For instance, the hydraulic cylinders and torque wrenches may not fit the next application making rental the better option for those

Considerations	Rent	Buy
Tight project timeline & budget	√	
Initial investment cost	√	
Asset management burden	√	
Access to rare specialized tools	√	
Well-maintained equipment	√	√
Ready access when needed	√	√

Low Profile Torque Wrench - W

Low Profile Torque Wrenches in the W-series from Enerpac have a superior strength to size ratio and provide easy access to difficult to reach applications without sacrificing endurance.

The X-Edition drive units, cassettes and most accessories are compatible with standard edition tools. These wrenches are ATEX-certified and have been developed with a tough manifold design with added safety feature for enhanced operator safety.



Model	Min. Nm	Max. Nm	Weight*	Hex Range "	Hex Range mm
W2000PX	276	2766	1,4 kg	1 1/16" - 2 3/8"	30- 60 mm
W4000PX	566	5661	2,0 kg	1 15/16" - 3 3/8"	36-85 mm
W8000PX	1148	11 484	3,0 kg	1 7/8" - 4 1/8"	50- 105 mm
W15000PX	2078	20 785	5,0 kg	2 7/16" - 4 5/8"	65- 115 mm
W22000X	3050	30 506	7,7 kg	2 15/16" - 5 3/8"	75- 135 mm
W35000X	4745	47 454	11,4 kg	3 1/8" - 6 1/8"	80- 155 mm

*Weight without hexagon cassette

Square Drive Torque Wrench - S

Torque Wrenches in the S-series have a compact, high-strength uni-body construction that provides small operating radius without sacrificing the endurance of the tool. They have been developed with a 360° click-on reaction arm with quick release lever that provides easier handling, even when wearing gloves



 ATEX CERTIFIED

Model	Min. Nm	Max. Nm	Weight	Square Drive
S1500X	195	1952	3,2 kg	3/4
S3000X	438	4373	5,6 kg	1
S6000X	834	7484	9,2 kg	1 1/2
S11000X	1516	15 151	15,8 kg	1 1/2
S25000X	3545	35 455	32,2 kg	2 1/2

Low Profile Torque Wrench - RTX

Low profile torque wrenches in the RTX-series from Atlas Copco combine high power-to-weight ratio, durability and hands-free operation. The result is a tool that is perfectly suited for low clearance applications that require high torque.

Use the RTX torque wrenches with standard set up or customize with accessories.



Model	Min. Nm	Max. Nm	Weight	Hex Range "	Hex Range mm
RTX-2	348	2318	2 kg	3/4" - 2 3/4"	19- 65 mm
RTX-4	784	5227	4,4 kg	1" - 3 1/8"	25- 85 mm
RTX-8	1658	11 051	9 kg	1 5/8" - 4 1/8"	46- 105 mm
RTX-14	2725	18 168	15 kg	2 1/2" - 5 3/8"	60- 135 mm
RTX-18	3879	24 191	23 kg	3 1/2" - 5 1/2"	75- 140 mm
RTX-30	6467	43 114	35,5 kg	3 1/2" - 6 1/2"	90- 165 mm

Square Drive Torque Wrench - RT

The RT Square Drive tool is robust, powerful and accurate. Perfectly suited for low clearance applications that require high torque. The splined square drive distributes load evenly through the drive components, providing full heavy-duty transmission of force.



Model	Min. Nm	Max. Nm	Weight	Square Drive
RT-05	75	538	0,4 kg	1/2"
RT-01	271	1817	1,9 kg	3/4"
RT-03	651	4379	3,9 kg	1"
RT-05	1132	7578	7,5 kg	1 1/2"
RT-08	1627	10 845	11,5 kg	1 1/2"
RT-10	2379	15 617	13,4 kg	1 1/2"

Impact Sockets



Drive Size	1/2"	3/4"	1"	1 1/2"	2 1/2"
Size Range	10- 32 mm	17- 41 mm	22- 46 mm	46- 120 mm	75- 160 mm
Type	Regular /Long	Regular / Long	Regular /Long	Regular /Long	Regular/Long

*Impact sockets are available in metric or imperial sizes



Pneumatic Torque Wrench - PTW

Enerpac Pneumatic torque wrenches are tough and reliable tools that are designed to provide fast, safe, and simple fastening for applications that require controlled bolting solutions.

The pneumatic torque wrenches are robust enough to withstand tough job site conditions, and are ideal for applications with a high volume of fastenings.



Model	Min. Nm	Nominal Nm	Weight	Square Drive "	Speed (RPM)
PTW1000C	407	1356	8,2 kg	1	12,6
PTW2000C	678	2712	8,8 kg	1	8,0
PTW3000C	1220	4067	10,4 kg	1	3,1
PTW6000C	1763	8135	17,7 kg	1 1/2	2,5

Cordless Screwdriver - LDA/LAW

Gedore LDA/LAW Solution cordless screwdrivers are made from lightweight high-performance aluminum, scores points with reliable documentation software, clear color display, low weight and maximum performance.

For maximum precision, the LDA/LAW Solution offers an optical zero-defect strategy: a sun-light-readable, digital color display visually represents the entire work process.



Model	Min. Nm	Max. Nm	Weight	Ø D (mm)	H (mm)
LDA-22	300	2200	5,6 kg	90	321
LDA-32	400	3200	6,1 kg	88	344
LDA-40	500	4000	6,1 kg	88	344
LDA-60	700	6000	7,8 kg	102	359

Cordless Torque Wrench - B-RAD

B-RAD offers higher speed and longer battery life while incorporating a new torque display with buttons. The B-RAD is especially suitable for pre-torque and service jobs where electricity or compressed air are not available.



Model	Min. Nm	Max. Nm	Weight	Drive Size “	Speed (RPM)
B-RAD 1400	270	1400	3,5 KG	0,75”	10,5
B-RAD 2000	400	2000	4,0 KG	1”	6,0
B-RAD 4000	800	4000	6,0 KG	1”	3,0
B-RAD 7000	1350	7000	8,8 KG	1.5”	2,1

Torque Wrench - Torcofix

Robust torque wrench with square drive and integrated ratchet-head function for controlled bi-directional tightening. Torcofix K torque wrenches offers controlled screw tightening in the most widely used range of 1- 850 Nm.



Drive Size"	Nm	Scale Ring	Weight
1/4	1-5	0,025 Nm	0,323 KG
1/4	5- 25	0,1 Nm	0,450 KG
3/8	10 - 50	0,25 Nm	0,540 KG
1/2	20 - 100	0,5 Nm	0,900 KG
1/2	40- 200	1 Nm	1,1 KG
1/2	60- 300	1 Nm	1,3 KG
3/4	80 - 400	1 Nm	1,86 KG
3/4	110- 550	1 Nm	3,56 KG
3/4	150- 750	1 Nm	4,5 KG
3/4	250- 850	1 Nm	4,7 KG

Torque Wrench - Dremaster

Dremaster® AM torque wrenches are lightweight and sturdy, very workshop-friendly with maximum precision even when subjected to extreme continuous use.

Most Dremometer models have separate ratchet heads, making it possible to work with or without the ratchet head function as desired.



Code	Drive Size"	No	Nm
2641232	1/2	DMK100	20- 100
2641240	1/2	DMK200	40- 200
2641259	1/2	DMK300	60- 300
2641267	3/4	DMK400	80- 400
2641275	3/4	DMK550	110- 550
2641283	3/4	DMK750	150- 750
2641291	3/4	DMK850	250- 850

Torque Wrench - Dremometer

Dremometer Z / SE torque wrenches from Gedore have a square drive and an integrated ratchet for extra control. Torque wrenches in the Z/SE-series have been developed with a replaceable head and a "push-button" release.

Dremometer Z and SE torque wrenches make a clicking sound when the desired torque is reached.



Type	Nm	Drive Size"	Code
AM	6- 30	1/4	7775440
A	8-40	3/8	7682000
B	25- 120	1/2	7683320
BC	40 - 200	1/2	7685530
C	60- 300	1/2	7685450
CD	80- 360	3/4	7688470
DS	110- 550	3/4	1427516
D	155- 760	3/4	7691500
DX	520- 1000	3/4	7674010
EK	600- 1500	1	2311267
E	750- 2000	1	7695250
F	1500- 3000	1 1/2	7717160

Torque Wrench - Stahlwille

Stahlwille Torque Wrenches are relentlessly tested, resulting in durability, strength, and longevity. These torque wrenches are used extensively in the aerospace, energy, and transport industries.

Stahlwille torque tools are designed for error-free selection of settings. They feature vibrant colour coding on the scale to easily differentiate between foot pounds and newton meters in bright sunlight or when covered by work debris.



Model	Nm
71/80	160- 800 N
730 Quick	80- 40 Nm
730/80	160- 800 Nm
721 Quick	30- 150
721 Quick	40- 200
721Nf	200- 1000
730N	4- 20
730 Fix	10- 50
701/2	1- 20
730D	10- 100
712R/6	3- 60



Safety Tools - kNm Hydraulikk

kNm Hydraulikk developed the kNm Safety Wrench to reduce the risk of falling objects and crush injuries for operators.

When using hydraulic torque wrenches, these are the greatest potential hazards.

The Safety Wrench developed by kNm Hydraulikk eliminates the use of impact wrenches and prevents rotation of the nut.

kNm Safety Wrench	"	mm
107	1 7/16	36,1
110	1 5/8	41,3
113	1 13/16	46
200	2	50,8
203	2 13/16	55,6
206	2 3/8	60,3
209	2 9/16	65,1
212	2 3/4	69,9
215	2 15/16	74,6
302	3 1/8	79,4
308	3 1/2	89,9
314	3 7/8	98,4
404	4 1/4	108
410	4 5/8	117,5



Safety Tools - kNm Hydraulikk

kNm Hydraulikk developed the kNm Safety Nut to reduce the risk of falling objects and crush-danger for operators. When using hydraulic torque wrenches, these are the greatest potential hazards. kNm Safety Nut is screwed onto the bolt connector after the torque wrench is mounted, meaning that the operator does not hold the tool during operation.

kNm Safety Nut comes with both metric and inch thread. The material is aluminum or POM.

kNm Safety Nut	Dimension
0_875	7/8-9 UNC
1_000	1-8 UNC
1_125	1 1/8-8 UN
1_250	1 ¼-8 UN
1_375	1 3/8-8 UN
1_500	1 ½-8 UN
1_625	1 5/8-8 UN
1_750	1 ¾-8 UN
1_875	1 7/8-8 UN
2_000	2-8 UN
2_250	2 ¼-8 UN
2_500	2 ½-8 UN



Torque Pumps - Air Driven



ATEX CERTIFIED

Type	Air Driven
Model	ZA4208TX-QR0P
Weight	52,2 KG
Max. Operating Pressure	700 bar
Oil Capacity	6,8 Liter
Oil Flow at 7 bar	5,7 l/min
Oil Flow at 350 bar	1,3 l/min
Oil Flow at 700bar	1 l/min

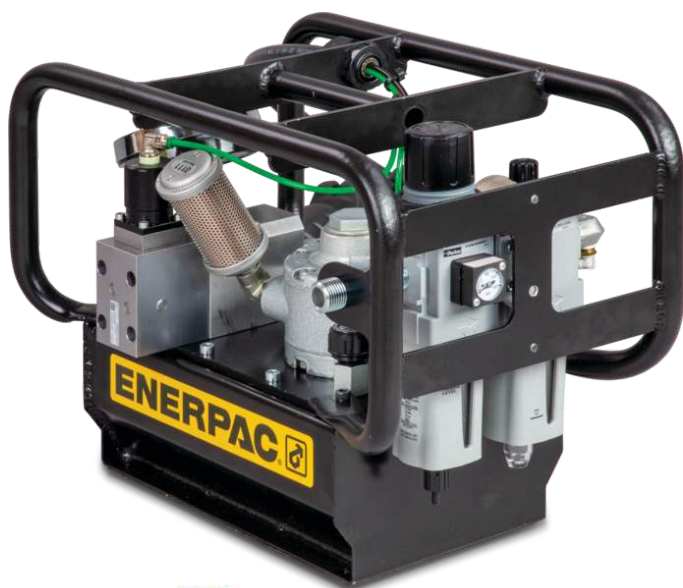

ATEX CERTIFIED

Type	Air Driven
Model	LA2504TX-QR
Weight	18 KG
Max. Operating Pressure	700 bar
Oil Capacity	3,0 Liter
Oil Flow at 350 bar	0,6 l/min
Oil Flow at 700bar	0,4 l/min

Torque Pumps - Air Driven



Type	Air Driven
Model	ZA4204TXQ
Weight	42,6 KG
Max. Operating Pressure	700 bar
Oil Capacity	2,7 Liter
Oil Flow at 50 bar	4,8 l/min
Oil Flow at 350 bar	1,1 l/min
Oil Flow at 700bar	0,8 l/min



Type	Air Driven
Model	Panther 380
Weight	22 KG
Max. Operating Pressure	700 bar
Oil Capacity	5.67 Liter
Ports	4
Oil Flow at 86bar	11.5 l/min
Oil Flow at 250bar	3.5 l/min
Oil Flow at 700bar	1.3 l/min

Torque Pumps - Electric



Type	Battery - 28 V, 3 Ah
Model	XC-1202MB
Weight	11,0 KG
Max. Operating Pressure	700 bar
Oil Capacity	2,0 Liter
Oil Flow at no load	2,05 l/min
Oil Flow at 140 bar	0,49 l/min
Oil Flow at 700bar	0,25 l/min



Type	Electric
Model	E-Pulse®
Weight	18 KG
Max. Operating Pressure	700 bar
Oil Capacity	3,0 Litres
Motor Size	1,63 kW
Flow at Rated Pressure	0,52 l/min



Type	Electric
Model	ZE2
Weight	42,4
Max. Operating Pressure	700- 800 bar
Flow at Rated Pressure	0,8- 1,0 l/min
Air Consumption	600- 2840 l/min
Reservoir Capacity	1,0- 8,0 Litres

Torque Pumps - Electric



Type	Electric
Model	ZU4T
Weight	32-34 KG
Max. Operating Pressure	700- 800 bar
Oil Capacity	4,0- 8,0 Litres
Motor Size	1,25 kW
Flow at Rated Pressure	1,0 l/min



Type	Battery - 82 V, 4 Ah
Model	ZC
Weight	33,3 KG
Max. Operating Pressure	700 bar
Oil Capacity	6,6 Liter
Motor Size	1,0 kW
Oil Flow at 276 bar	1,31 l/min
Oil Flow at 700bar	0,52 l/min

Tensioners Pumps



HYDRAMAX® TOPSIDE TENSIONER

Type	HM
Bolt Range	M20- M39
Bolt Range - "	¾- 1 ½"
Max. Load Capacity	134 - 624 kN
Stroke	10- 15 mm
Max. Operating Pressure	1500 bar



AQUAJACK® SUBSEA TENSIONER

Type	AJ
Bolt Range	M16- M90
Bolt Range - "	¾- 3 ½"
Max. Load Capacity	72,4 - 2316 kN
Stroke	30 mm
Max. Operating Pressure	1500 bar



CRANE TENSIONER- CUSTOMISABLE

Type	Crane Tensioner
Bolt Range	Customisable
Max. Load Capacity	Customisable
Stroke	Customisable
Max. Operating Pressure	Customisable

Tensioners



AQUAMAX® SUBSEA TENSIONER

Type	AM
Bolt Range	M20- M100
Bolt Range - "	¾- 4"
Max. Load Capacity	134 - 4643 kN
Stroke	30 mm
Max. Operating Pressure	1500 bar



HL TENSIONER

Type	HL
Bolt Range	M16- M100
Bolt Range - "	¾- 4"
Max. Load Capacity	140 - 2704 kN
Stroke	15 mm
Max. Operating Pressure	1041 bar



POWER GENERATION BOLT TENSIONERS

Type	PGT
Bolt Range	M20- M72
Max. Load Capacity	203,7 - 2969,6 kN
Stroke	15 mm
Max. Operating Pressure	1350- 1500 bar

Tensioner Pumps



Type	Electric
Model	ZUTP
Weight	29,5 KG
Max. Operating Pressure	1500 bar
Motor Size	1,25 kW
Flow at Rated Pressure	0,13 l/min
Reservoir Capacity	4,0 Litres
Output Flow Rate at 1500 bar	2,90 l/min



Type	Air Driven
Model	D600
Weight	26,5 KG
Max. Operating Pressure	1500 bar
Ports	2
Oil Capacity	9 Liter
Oil Flow at 250 bar	0,9 l/min
Oil Flow at 700 bar	0,7 l/min

Tensioner Pumps



Type	Air Driven
Model	D500
Weight	22,5 KG
Max. Operating Pressure	1500 bar
Ports	2
Oil Capacity	9 Liter
Oil Flow at 250 bar	0,3 l/min
Oil Flow at 700 bar	0,2 l/min



Type	Air Driven
Model	D500 HP
Weight	22,5 KG
Max. Operating Pressure	2275 bar
Oil Capacity	9 Litres
Oil Flow at 250 bar	0,3 l/min
Oil Flow at 700 bar	0,2 l/min

Nut Splitters & Nut Cutters

MODEL	TYPE	POWER SOURCE	MAX. CAPACITY	Weight
WMC	Self-Contained Cutter	Hydraulic	3 - 20 ton	3,6 - 11,3 KG
EBC	Cordless Bar Cutter	Battery (12 and 18 Volt)	HRc 43	8,7 KG
EBH	Bar Cutter	Hydraulic	HRc 43	21 - 136 KG
EBE	Bar Cutter	Electric	HRc 43	13,2 - 15,9 KG
ECCE	Chain Cutter	Electric	HRc 46	25 - 48 KG
WHC	Cutter Head	Hydraulic	3 - 20 ton	3,2 - 14,5 KG
WMC	Self-Contained Cutter	Hydraulic	3 - 20 ton	3,6 - 11,3 KG
WHC	Wire & Cable Cutter	Hydraulic	3 - 20 ton	3,2 - 14,5 KG
EWCH	Wire & Cable Cutter	Hydraulic	65 daN/mm ²	54 - 150 KG
EWCE	Wire & Cable Cutter	Electric	HRc 48	25 KG
EFBE	Flat Bar Cutter	Electric	HRc 33	21 - 30 KG
EDCH	Decommissioning Cutter	Hydraulic	65 daN/mm ²	11,5 - 24,2 KG



Nut Splitters & Nut Cutters



Model	NC-Series
Type	Hydraulic Nut Cutter
Bolt Range	M6 - M478
Power Head	Single - Acting
Hexagon Nut Range	10- 75 mm
Capacity - Cutting Force	49 - 882 kN
Max. Operating Pressure	700 bar

Nut Splitters & Nut Cutters



Model	NS & NSH-Series
Type	Hydraulic Nut Splitter
Bolt Range	M45 - M90
Power Head	Single & Double - Acting
Hexagon Nut Range	70- 130 mm
Capacity - Cutting Force	1025 - 1733 kN
Max. Operating Pressure	700 bar

Flange Spreader Tools



MODEL SWI1214TMSTDEX

TYPE Mechanical

MAX. FORCE 140 kN

CAPACITY 14 Metric Ton

MAX. SPREAD 103,5 mm

WEIGHT 17 KG

 ATEX CERTIFIED



MODEL SWI2025TEMAXEX

TYPE Hydraulic (External)

MAX. FORCE 240 kN

CAPACITY 24 Metric Ton

MAX. SPREAD 103,5 mm

WEIGHT 27,5 KG

 ATEX CERTIFIED



MODEL SWi2025TISTDEX

TYPE Hydraulic (Integral)

MAX. FORCE 240 kN

CAPACITY 24 Metric Ton

MAX. SPREAD 103,5 mm

WEIGHT 17,5 KG

 ATEX CERTIFIED

Flange Spreader Tools



MODEL	SWI1214TMSTD-SPB
TYPE	Mechanical
MAX. FORCE	140 kN
CAPACITY	14 Metric Ton
MAX. SPREAD	103,5 mm
WEIGHT	13 KG



MODEL	SWi2025TESTDSPB
TYPE	Hydraulic (External)
MAX. FORCE	240 kN
CAPACITY	24 Metric Ton
MAX. SPREAD	103,5 mm
WEIGHT	20,7 KG



MODEL	SWi2025TISTDSPB
TYPE	Hydraulic (Integral)
MAX. FORCE	240 kN
CAPACITY	24 Metric Ton
MAX. SPREAD	103,5 mm
WEIGHT	9,3 KG

Flange Alignment Tools



Model	FA1TM
Type	Mechanical
Max. Reaction Force	10 kN
Capacity	1 Metric Ton
Min. Bolt Size	16 mm
Weight	2,3 KG



Model	FA4TM
Type	Mechanical
Max. Reaction Force	40 kN
Capacity	4 Metric Ton
Min. Bolt Size	25 mm
Weight	8,6 KG



Model	FA9TESTD
Type	Hydraulic
Max. Reaction Force	90 kN
Capacity	9 Metric Ton
Min. Bolt Size	35,5 mm
Weight	14,5 KG

Flange Alignment Tools



Model	ATM2
Type	Flange Alignment
Max. Reaction Force	10 kN
Capacity	1 Metric Ton
Min. Bolt Size	16 mm
Weight	1,6 KG



Model	ATM4
Type	Flange Alignment
Max. Reaction Force	4 Metric Ton
Capacity	40 kN
Min. Bolt Size	25 mm
Weight	8,6 KG



Model	ATM9
Type	Flange Alignment
Max. Reaction Force	90 kN
Capacity	35,5 mm
Min. Bolt Size	35,5 mm
Weight	14,5 KG

Flange Secure Grip Tools

The Equalizer™ range of patented flange spreading tools have been developed to aid and simplify the maintenance of flange joints. No longer will those tasked with separating flanges have to rely on using ropes and pulleys, podgers, tirsors, come-alongs or hammers – there is a safe, quick and effective alternative, the Equalizer™ range of spreaders. These spreaders use mechanical and hydraulic principles for separating flanges and can spread small, medium or large flange joints. Tool selection is made on the basis of the access gap between the flange faces, the flange size and the required scope of work.



Model	Max. Spreading Force	Max. Spreading Distance	Weight
SG4TM	4.2 TON	75 mm	4,5 KG
SG6TM	6.7 TON	80 mm	7,5 KG
SG11TM	12.4 TON	90 mm	10,5 KG
SG13TE	14.6 TON	115 mm	21,5 KG
SG15TES	16.9 TON	100 mm	26 KG

Ola Spreader

kNm flange spreader was developed to simplify the disassembly and replacement of gaskets in flanged connections.

The spreader is designed and adapted for flanges up to 6" in pressure class 600.

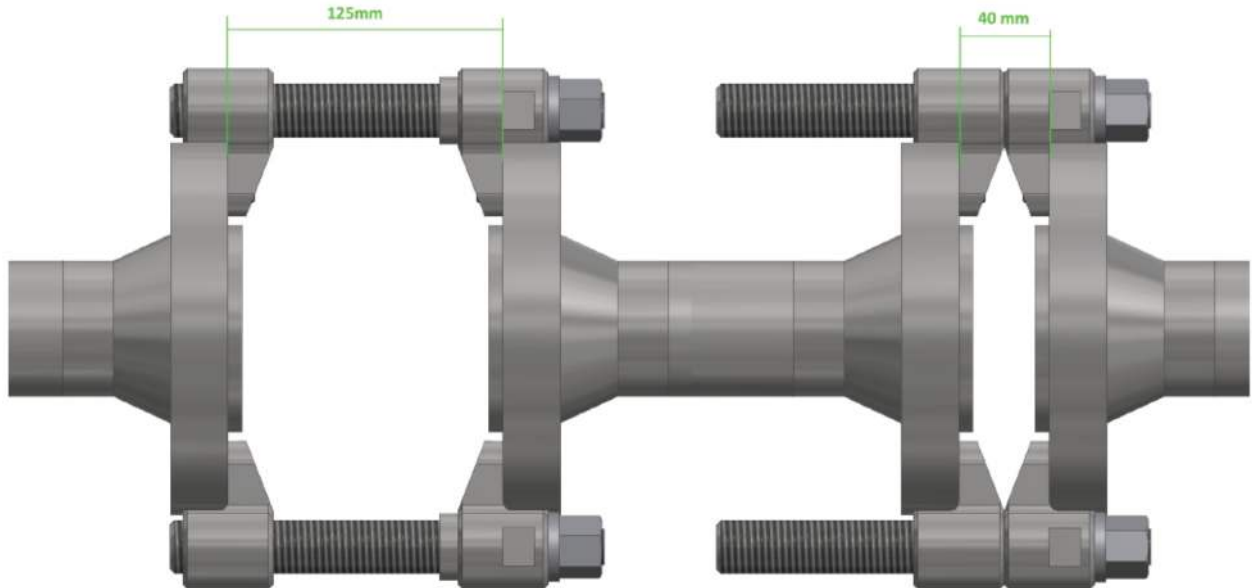

Weight	Max. Spreading Force	Max. Torque
1.3 KG	2000 KG	80 Nm

CYLINDERS

MODEL	TYPE	CAPACITY	STROKE
RC TRIO	Single-Acting	5 - 95 TON	16 - 362 mm
RAC	Single-Acting	10 - 150 TON	50 - 250 mm
RACL	Single-Acting Lock Nut Cylinders	20 - 150 TON	50 - 250 mm
RACH	Single-Acting Hollow Plunger Cylinders	20 - 150 TON	50 - 250 mm
RAR	Double-Acting	20 - 150 TON	50 - 250 mm
RARH	Double-Acting Hollow Plunger Cylinders	30 - 150 TON	50 - 250 mm
CULP	Ultra-Flat Cylinders with Stop Ring	10 - 100 TON	6 mm
CUSP	Ultra-Flat High-Tonnage Cylinders	10 - 1000 TON	Stroke Straight / Tilted Stroke: 7 - 17 mm / 6 - 10 mm



CYLINDERS

MODEL	TYPE	CAPACITY	STROKE
LPL	Single-Acting Low-Height Lock Nut Cylinders	60 - 500 TON	45 - 50 mm
RSM & RCS	Single-Acting Low-Height Cylinders	5 - 150 TON	6 - 62 mm
RLT	Single-Acting Low-Height Telescopic Cylinders	4,4 - 74,1 TON	17 - 40 mm
RT	Single-Acting Telescopic Cylinders	14 - 31 TON	270 - 600 mm
BRC/BRP	Single-Acting Pull Cylinders	2,5 - 50 TON	127 - 154 mm
RCH	Single-Acting Hollow Plunger Cylinders	13 - 95 TON	8 - 155 mm
RRH	Double-Acting Hollow Plunger Cylinders	30 - 145 TON	38 - 258 mm
RR	Double-Acting Long Stroke Cylinders	10 - 520 TON	57 - 1219 mm



Hand Pumps

Model	Pump Type	Useable Oil Capacity	Max. Flow at Rated Pressure	Valve Operation	Operating Pressure	Weight
P141	Single Speed	327 cm ³	0,90 cm ³ /stroke	Manual	700 bar	2,4 KG
P142	Two Speed	327 cm ³	0,90 cm ³ /stroke	Manual	700 bar	2,4 KG
P391	Single Speed	901 cm ³	2,47 cm ³ /stroke	Manual	700 bar	4,1 KG
P392	Two Speed	901 cm ³	2,47 cm ³ /stroke	Manual	700 bar	4,1 KG
P80	Two Speed	2200 cm ³	2,46 cm ³ /stroke	Manual	700 bar	10,7 KG
P84	Two Speed	2200 cm ³	2,46 cm ³ /stroke	Manual	700 bar	11,8 KG
P801	Two Speed	4100 cm ³	2,46 cm ³ /stroke	Manual	700 bar	14,1 KG
HPT1500	Two Speed	2540 cm ³	0,61 cm ³ /stroke	Manual	1500 bar	9,0 KG
P2282	Two Speed	983 cm ³	0,61 cm ³ /stroke	Manual	2800 bar	6,4 KG



Components - Hoses

Hose Length	Operating Pressure
0,6 M	700 bar
0,9 M	700 bar
1,8 M	700 bar
3,0 M	700 bar
6,1 M	700 bar
15,0 M	700 bar
30,0 M	700 bar
1,8 M	1500 bar
3,0 M	1500 bar
6,1 M	1500 bar
9,1 M	1500 bar
15,0 M	1500 bar
30,0 M	1500 bar

*Different couplers available

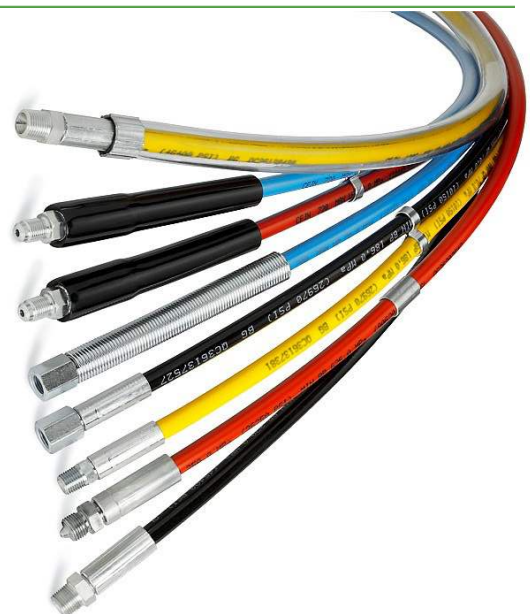

Hose Reels



TYPE	Operating Pressure
Single Hose Reel	1500 bar
Twin Hose Reel	700 bar
Hose Reel Stand	*No fittings



Components - Gauges



MODEL	T- Series
Pressure Range	0- 3500 bar
Face Diameter	162- 192 mm
Accuracy	± 0,5- 1,5%
Material	Alloy & Stainless Steel



MODEL	DGR- Series
Pressure Range	0- 1380 bar
Voltage	3 Volt (Battery)
Accuracy	± 0,25%
Display	Bar, psi, Mpa & kg/cm ²

Components - Gauges



MODEL	GA45GC
Pressure Range	0- 700 bar
Scale	Dual
Accuracy	± 0,5- 1,5%
Material	Alloy & Stainless Steel



MODEL	G- Series
Scale	Dual
Pressure Range	0- 1000 bar
Face Diameter	63- 100 mm
Accuracy	± 1,0- 1,5%
Display	Bar, psi, Mpa & kg/cm2

Components - Manifolds



Model	SFM - Series
Compatibility	Single-Acting
Inlet Connection	1 x Power Pump
Outlet Connection	Max. 4 Cylinders
Min. Pump Flow	0,82 l/min
Max. Operating Pressure	700 bar



Model	AMGC41	AMGC42
Compatibility	Single Acting	Double Acting
Inlet Connection	1	1
Outlet Connection	4	4
Max. Operating Pressure	700 bar	700 bar
Weight	10,8 KG	17,4 KG

Components - Manifolds



Model **AM21**

Inlet Ports	2
Outlet Ports	2
Oil Ports	3/8" NPTF
Max. Operating Pressure	700 bar



Model **AM41**

Inlet Ports	1
Outlet Ports	4
Oil Ports	3/8" NPTF
Max. Operating Pressure	700 bar

kNm Hydraulikk
Skvadronvegen 27
4050 Sola

post@knm-hydraulikk.no
www.knm-hydraulikk.no



www.knm-hydraulikk.no