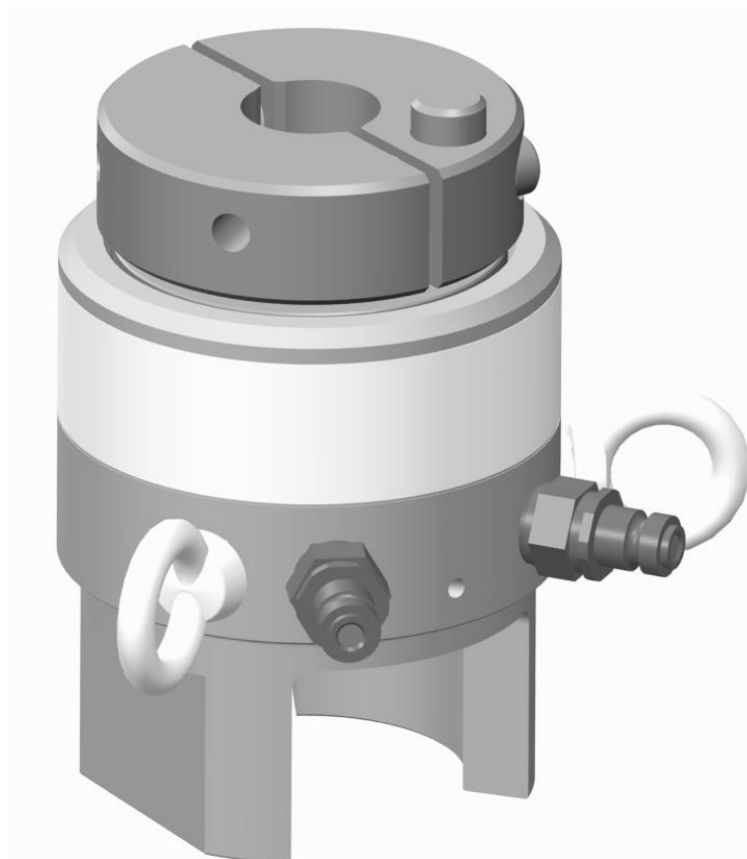


## AQUAMAX<sup>®</sup> BOLT TENSIONER



Operating and Maintenance Instructions  
Original Instructions



**INDEX**

**1. SAFETY NOTES ..... 3**

**2. INTRODUCTION ..... 6**

    2.1. GENERAL ..... 6

    2.2. INTENDED USE OF THE EQUIPMENT ..... 7

    2.3. INCORRECT USE OF THE EQUIPMENT ..... 7

    2.4. TENSIONER FEATURES (FIGURE 1) ..... 8

**3. TECHNICAL SPECIFICATION ..... 10**

    3.1. MAXIMUM WORKING PRESSURE ..... 10

    3.2. STEP-UP WASHERS ..... 11

    3.3. PUMP REQUIREMENTS ..... 13

**4. ASSEMBLY ..... 14**

    4.1. APPLICATION PREPARATION ..... 14

    4.2. TENSIONING TOOL ASSEMBLY ..... 17

    4.3. HOSE CONNECTION ..... 17

**5. OPERATING PROCEDURES ..... 20**

    5.1. AQUAMAX® BOLT TENSIONING PROCEDURE – 100% TOOL COVER ..... 20

    5.2. AQUAMAX® BOLT TENSIONING PROCEDURE – 50% TOOL COVER ..... 21

    5.3. AQUAMAX® BOLT DE-TENSIONING PROCEDURE ..... 22

    5.4. RAM RETRACTION ..... 23

    5.5. USING THE OVERSTROKE ELIMINATION DEVICE ..... 23

**6. MAINTENANCE ..... 26**

    6.1. PRE-USE MAINTENANCE ..... 26

    6.2. POST-USE MAINTENANCE ..... 26

    6.3. AQUAMAX® TENSIONER FULL MAINTENANCE / SERVICE ..... 27

    6.4. CHANGING THE SEALS ..... 27

    6.5. ASSEMBLY OF BANJO FITTINGS ..... 31

**7. TROUBLESHOOTING ..... 32**

**8. EMERGENCY MEASURES ..... 33**

    8.1. STANDARD HEXAGONAL NUTS USED AS REACTION NUTS ..... 33

**9. STORAGE AND TRANSPORTATION OF EQUIPMENT ..... 34**

    9.1. STORAGE ..... 34

    9.2. TRANSPORTATION ..... 34

**10. ANCILLARY/SPARE PARTS ..... 35**

    10.1. ANCILLARY EQUIPMENT ..... 35

    10.2. RECOMMENDED SPARES ..... 37

    10.3. SPARE PART ORDERING INFORMATION ..... 37

**11. APPROVED DISTRIBUTORS ..... 37**

**12. TRAINING ..... 37**

**13. REVISION HISTORY ..... 37**

**ANNEX 1. CE DECLARATION OF CONFORMITY ..... 38**

**ANNEX 2. ENVIRONMENTAL STATEMENT ..... 39**

Issuer: GRM  
 Approval: MH  
 Revision: AH  
 Date: 12-Jul-16

# 1. SAFETY NOTES



**READ THE OPERATING INSTRUCTIONS**



**CAUTION:** Keep away from oil leakages at high pressure. Fluid escaping from highly pressurised equipment can penetrate the skin, which can cause blood poisoning. In the event of such an accident immediate medical attention should be sought.



**In the event of accident or breakdown:**  
Stop pump, disconnect equipment and turn off air supply.



Wear safety glasses to protect against flying particles



Wear safety shoes at all times



Wear ear protection during operation. Prolonged exposure to high intensity noise may cause loss of hearing



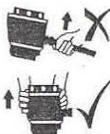
Wear safety gloves



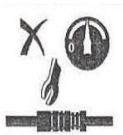
Wear protective clothing



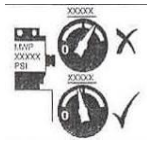
Eye protection must be used.  
Wear gloves at all times  
Rope off working area and place warning signs.



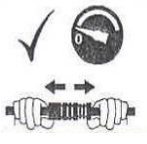
Do not pick up tools by hydraulic hose.  
Observe correct lifting procedure at all times.



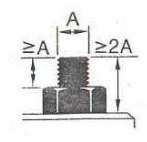
Do not tamper with hose connections when under pressure



Do not exceed the maximum working pressure of the tool.  
21750psi (1500 bar)



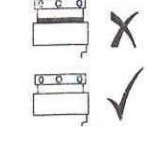
System must be at zero pressure before couplings are disconnected.  
Check integrity of system before applying any pressure.



Ensure that the distance between the nut seating face and end of stud is more than twice the thread diameter.  
Ensure the length of exposed thread is greater than the stud diameter.  
Ensure that the nut height is equivalent to the diameter of the stud (except metric).



Never apply pressure to disconnected fittings.  
Always check that all connections are good before applying pressure to the system.



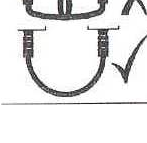
Do not exceed the maximum stroke of the tool as indicated on the ram of the tool.



Never leave the system unattended when under pressure.



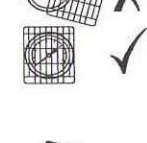
When the system is under pressure DO NOT STAND IN LINE with the direction of force of the tensioners. This is a danger area. Keep this area clear of personnel at all times when the system is under pressure.



Do not over-bend or kink hoses.



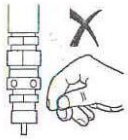
Never pressurise the pump with a disconnected fitting.



Do not remove gauge covers when fitted.



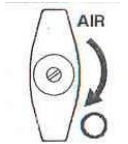
Site pump on a secure, flat, level surface.



Do not tamper with air pressure relief safety valve on pump.



Check date of calibration certification. If recalibration date has passed, recalibrate gauge.



If air supply is interrupted, turn off air stop valve on pump.



24 Hour emergency contact number 44 (0)121 505 0600



Only use genuine Hydratight parts.

## **2. INTRODUCTION**

### **2.1. GENERAL**

- 2.1.1.** The aim of the AquaMax<sup>®</sup> Bolt Tensioning System is to quickly and accurately apply a pre-determined load to a nut and bolt assembly. It has been primarily developed for use in the subsea environment where speed, ease of operation and reliability are paramount.
- 2.1.2.** In use, an AquaMax<sup>®</sup> tensioner is attached to every stud bolt in the joint assembly allowing simultaneous and uniform bolt tightening. The AquaMax<sup>®</sup> Tensioner is applied to an extended portion of stud bolt passing through a pre-drilled standard hexagon nut. A reaction nut is then fitted to the stud bolt protruding above the tensioner and screwed down until it seats against the tensioner ram. Each AquaMax<sup>®</sup> Tensioner is connected together using high pressure flexible hoses to form a hydraulic 'harness' which is connected to the pump unit at the surface via the downline hose, mounted on the hose reel.
- 2.1.3.** A pre-determined hydraulic pressure is applied to the system, thus stretching the stud bolt as the ram pushes against the reaction nut. As the stud bolt stretches, the pre-drilled standard nut lifts from the flange surface. The bolt load is retained in each bolt by inserting a tommy bar through the bridge window, into the pre-drilled hole in each flat of the hexagonal nut and turning in a clockwise direction until the nut seats against the flange surface. The hydraulic pressure is released and the load is retained in each bolt. The AquaMax<sup>®</sup> Tensioners are then removed as bolt tightening is complete.
- 2.1.4.** Modification to any part of the equipment outlined in this manual should not be attempted, nor any component part be replaced without first consulting Hydratight. Modifications may render the equipment dangerous. Component parts are each rated to suit the demands of the overall equipment design and replacement with similar items without provenance may lead to unexpected and dangerous accidental features.

If any equipment abuse is evident, the warranty will be invalidated and Hydratight will not be made responsible for an injury due to misuse or failure to comply with the above safety notes.

## 2.2. INTENDED USE OF THE EQUIPMENT

The standard range of AquaMax<sup>®</sup> Tensioners has been designed to interface with the following application conditions:

- 2.2.1. The stud bolt has been prepared in accordance with Section 4.1.
  - 2.2.2. Thread form to suit the application.
  - 2.2.3. Nut height:
    - Inch heavy series hexagon nut i.e. nut height = 1 x bolt diameter (Ref: BS4882 / ANSI B18.2.2)
    - Metric normal series hexagon nut i.e. nut height = 0.8 x bolt diameter (Ref: BS4882)
    - Metric heavy series hexagon nut i.e. nut height = 1 x bolt diameter (Ref: BS EN ISO4033 / ANSI B18.2.4)
    - (Other nut configurations and of different proportions can be accommodated, but with modifications to tooling).
  - 2.2.4. Nut A/F:
    - Inch heavy series hexagon nut (Ref: BS4882 / ANSI B18.2.2)
    - Metric normal series hexagon nut (Ref: BS4190 / ISO 272 to Normal Series)
    - (Other nut configurations and of different proportions can be accommodated, but with modifications to standard tooling).
- NOTE: Metric heavy series nut A/F sizes in accordance with ASME B18.2.4.6M and ISO 272 can result in certain tensioners not fitting. Care should be taken to ensure the correct tools are selected in such instances.*
- 2.2.5. The contact area for the bridge is flat and complete. If washers are used, they must be greater than the bridge diameter and strong enough to withstand the tensioner force.
  - 2.2.6. The tensioner is removed from the application once the load has been induced into the threaded fastener. The tensioner is not designed to induce and maintain the load in the fastener for a long period of time (i.e. used as a hydraulic nut).
  - 2.2.7. Designed for use on Standard, Non-Live (i.e. no line pressure or medium present) ANSI B16.5, MSS-SP44, API 6A/17D and compact flanges, although the compact design enables use on many other applications. Non-standard applications will require a dimensional clearance check.
  - 2.2.8. Ensure that the strengths of the fasteners are known and that the recommended tensioning applied loads are well within the safe limits.

## 2.3. INCORRECT USE OF THE EQUIPMENT

The AquaMax<sup>®</sup> Tensioner must not be used in the following scenarios or severe component damage may occur:

- 2.3.1. As multiple units on the same fastener (i.e. one tensioner being placed on top of another to increase the load in the fastener). Load will be transferred to the bottom tensioner possibly resulting in tool failure.
- 2.3.2. When the tensioner is not sitting squarely on the flange surface i.e. the axis of the tool is not parallel to the axis of the fastener. Possible causes are due to the flange/pipe weld obstructing the load cell or the flange hub radius obstructing the bridge. Upon pressurisation the tensioner will have a tendency to self-align which may result in damage to the tensioner or plant.
- 2.3.3. Without a Hydratight Quick-Fastening or solid reaction nut. The ram has been specifically designed to interface with Hydratight reaction nuts and adaptor washers.

## 2.4. TENSIONER FEATURES (FIGURE 1)

Since the subsea environment is particularly harsh for both equipment and operator, the AquaMax<sup>®</sup> Tensioner has been purposely designed to include a host of features to benefit its use and operation.

### 2.4.1. OVERSTROKE ELIMINATION (1)

All Tensioners in the AquaMax<sup>®</sup> range are designed to ensure that maximum strokes can be used without overstroking the ram. As the tensioner operates, the pre-drilled nut lifts from the flange surface at a proportional rate to the ram stroke. As the ram approaches its maximum stroke, the top surface of the pre-drilled nut will contact the underside of the tensioner body, preventing further movement of the ram.

### 2.4.2. LONG RAM STROKE (2)

30mm maximum ram stroke (20mm for AM01 & AM02) ensures that in most cases joints can be tensioned without the need to reset the ram.

### 2.4.3. HIGH LOAD CAPACITY AND COMPACT DESIGN (3)

This range of tools has been designed to fit Compact flanges whilst developing enough load for those applications the resulting compact tool design allows easier access into restricted applications and low headroom clearances.

### 2.4.4. MISALIGNMENT COMPENSATION (4)

Unique floating ram design allows tilt in any direction, thus eliminating ram seizure and aiding tensioner retraction.

### 2.4.5. RAM STROKE INDICATOR (5)

The integral ram stroke indicator allows ram stroke to be viewed, measured and controlled.

### 2.4.6. SEALS (6)

Low friction, composite seals and rigid back-up rings are incorporated within a unique ram design for improved life and reliability.

### 2.4.7. QUICK-FASTENING REACTION NUT (7)

Quick Fastening reaction nut design allows rapid tensioner removal as well as quick application to long bolts and damaged threads.

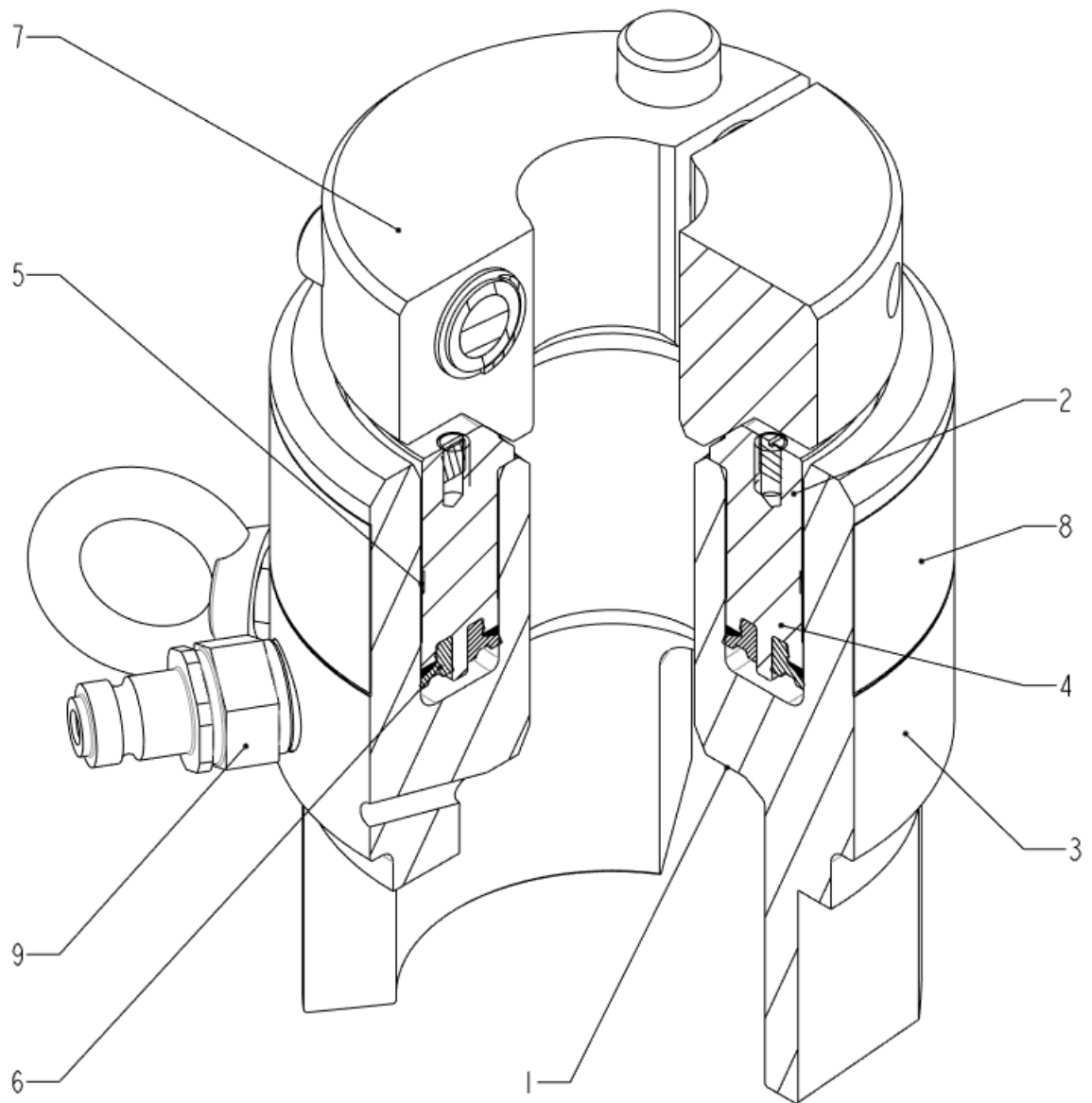
### 2.4.8. ANTI-SLIP SURFACES (8)

Special anti-slip and photoluminescent tensioner surface improves operator grip and visibility. The photoluminescent surface can be charged by either natural or artificial light.

### 2.4.9. HOSE CONNECTION (9)

Integral manifold design simplifies hose connection particularly in areas of poor visibility.

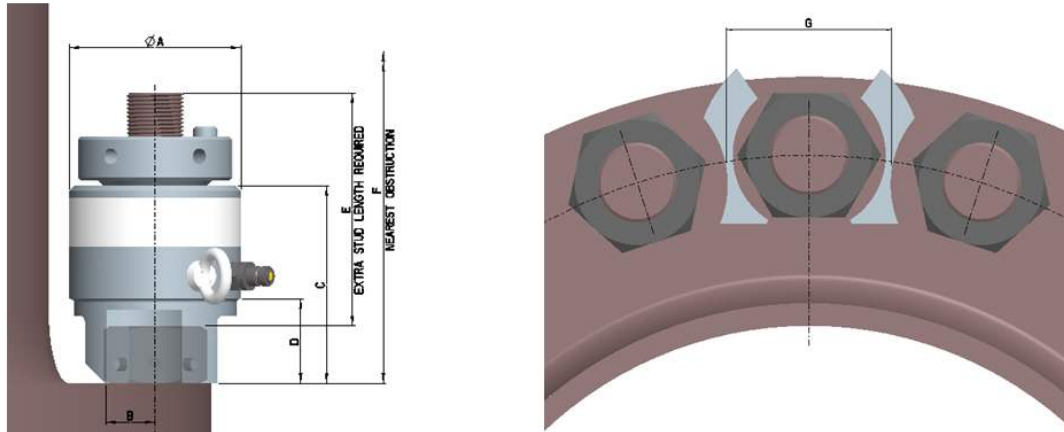




**Figure 1: THE AQUAMAX® BOLT TENSIONER**

### 3. TECHNICAL SPECIFICATION

#### 3.1. MAXIMUM WORKING PRESSURE



| Tool Ref | Bolt Diameter      |             | Tool HYD Area   |                 | Max Load |         |        | Weight |       | A     | B    | C     | D     | E   | F     | G     |
|----------|--------------------|-------------|-----------------|-----------------|----------|---------|--------|--------|-------|-------|------|-------|-------|-----|-------|-------|
|          | in                 | mm          | in <sup>2</sup> | mm <sup>2</sup> | Tonf     | lbf     | kN     | lb     | kg    | mm    | mm   | mm    | mm    | mm  | mm    | mm    |
| AM01     | 3/4"               | M20         | 1.39            | 894             | 13.45    | 30128   | 134.0  | 3.6    | 1.65  | 64.0  | 15.6 | 96.0  | 35.0  | 101 | 224.0 | 48.1  |
| AM02     | 3/4"               | M20         | 1.92            | 1241            | 18.67    | 41821   | 186.0  | 4.1    | 1.85  | 69.0  | 18.8 | 93.5  | 35.0  | 101 | 224.0 | 55.5  |
|          | 7/8"               | M22         |                 |                 |          |         |        |        |       |       |      |       |       |     |       |       |
| AM03     | 7/8" *<br>1"       | M20         | 2.52            | 1627            | 24.48    | 54835   | 244.0  | 6.6    | 3.00  | 81.0  | 19.9 | 122.5 | 46.0  | 128 | 295.0 | 59.4  |
|          |                    | M24         |                 |                 |          |         |        |        |       |       |      |       |       |     |       |       |
|          |                    | M27         |                 |                 |          |         |        |        |       |       |      |       |       |     |       |       |
| AM04     | 1"<br>1 1/8"       | M24         | 3.34            | 2154            | 32.42    | 72621   | 323.0  | 7.9    | 3.59  | 89.0  | 23.2 | 125.5 | 50.0  | 129 | 303.0 | 73.8  |
|          |                    | M27         |                 |                 |          |         |        |        |       |       |      |       |       |     |       |       |
|          |                    | M30         |                 |                 |          |         |        |        |       |       |      |       |       |     |       |       |
| AM05     | 1 1/8" *<br>1 1/4" | M30         | 4.26            | 2748            | 41.36    | 92646   | 412.1  | 9.8    | 4.45  | 98.0  | 27.2 | 130.8 | 52.0  | 134 | 313.0 | 74.0  |
|          |                    | M33         |                 |                 |          |         |        |        |       |       |      |       |       |     |       |       |
| AM06     | 1 1/4"<br>1 3/8"   | M33         | 5.29            | 3414            | 51.38    | 115091  | 512.0  | 11.6   | 5.24  | 107.0 | 31.6 | 132.0 | 55.0  | 128 | 309.0 | 86.4  |
|          |                    | M36         |                 |                 |          |         |        |        |       |       |      |       |       |     |       |       |
| AM07     | 1 3/8" *<br>1 1/2" | M36         | 6.44            | 4155            | 62.53    | 140067  | 623.0  | 14.4   | 6.52  | 115.5 | 33.2 | 138.0 | 58.5  | 137 | 326.0 | 86.3  |
|          |                    | M39         |                 |                 |          |         |        |        |       |       |      |       |       |     |       |       |
| AM08     | 1 1/2"<br>1 5/8"   | M39         | 7.70            | 4969            | 74.78    | 167507  | 745.1  | 17.8   | 8.05  | 125.0 | 34.0 | 144.5 | 61.5  | 144 | 339.0 | 96.0  |
|          |                    | M42         |                 |                 |          |         |        |        |       |       |      |       |       |     |       |       |
| AM09     | 1 5/8" *<br>1 3/4" | M42         | 9.08            | 5855            | 88.12    | 197389  | 878.1  | 21.5   | 9.76  | 133.5 | 38.2 | 153.0 | 65.5  | 154 | 360.0 | 96.8  |
|          |                    | M45         |                 |                 |          |         |        |        |       |       |      |       |       |     |       |       |
| AM10     | 1 3/4"<br>1 7/8"   | M45         | 10.57           | 6817            | 102.59   | 229802  | 1022.2 | 24.2   | 10.99 | 142.5 | 42.9 | 154.0 | 67.5  | 149 | 360.0 | 108.4 |
|          |                    | M48         |                 |                 |          |         |        |        |       |       |      |       |       |     |       |       |
| AM11     | 1 7/8"<br>2"       | M48         | 12.17           | 7849            | 118.13   | 264611  | 1177.1 | 27.1   | 12.27 | 152.0 | 49.3 | 155.0 | 70.0  | 147 | 363.0 | 116.6 |
|          |                    | M52         |                 |                 |          |         |        |        |       |       |      |       |       |     |       |       |
| AM12     | 2" *<br>2 1/4"     | M52         | 15.70           | 10130           | 152.46   | 341510  | 1519.1 | 35.3   | 16.03 | 170.5 | 49.3 | 164.0 | 76.0  | 156 | 382.0 | 130.2 |
|          |                    | M56         |                 |                 |          |         |        |        |       |       |      |       |       |     |       |       |
| AM13     | 2 1/4"<br>2 1/2"   | M56         | 19.68           | 12696           | 191.08   | 428019  | 1904.0 | 42.5   | 19.27 | 185.5 | 58.9 | 168.0 | 82.0  | 154 | 390.0 | 143.4 |
|          |                    | M60         |                 |                 |          |         |        |        |       |       |      |       |       |     |       |       |
| AM14     | 2 1/2" *<br>2 3/4" | M60         | 21.82           | 14078           | 211.88   | 474611  | 2111.2 | 48.9   | 22.19 | 198.0 | 62.9 | 177.5 | 87.0  | 164 | 392.0 | 158.7 |
|          |                    | M64         |                 |                 |          |         |        |        |       |       |      |       |       |     |       |       |
|          |                    | M68         |                 |                 |          |         |        |        |       |       |      |       |       |     |       |       |
| AM15     | 2 3/4"<br>3"       | M68         | 26.25           | 16934           | 254.85   | 570864  | 2539.4 | 61.4   | 27.86 | 214.5 | 68.6 | 188.0 | 95.0  | 173 | 438.0 | 176.0 |
|          |                    | M72         |                 |                 |          |         |        |        |       |       |      |       |       |     |       |       |
|          |                    | M76         |                 |                 |          |         |        |        |       |       |      |       |       |     |       |       |
| AM16     | 3" *<br>3 1/4"     | M76         | 31.07           | 20048           | 301.72   | 675853  | 3006.3 | 75.2   | 34.12 | 233.0 | 69.4 | 195.0 | 103.0 | 184 | 460.0 | 186.1 |
|          |                    | M80         |                 |                 |          |         |        |        |       |       |      |       |       |     |       |       |
|          |                    | M85         |                 |                 |          |         |        |        |       |       |      |       |       |     |       |       |
| AM17     | 3 1/4"<br>3 1/2"   | M80         | 36.30           | 23421           | 352.48   | 789555  | 3512.1 | 87.2   | 39.55 | 248.0 | 78.2 | 200.0 | 109.0 | 180 | 467.0 | 198.6 |
|          |                    | M85         |                 |                 |          |         |        |        |       |       |      |       |       |     |       |       |
|          |                    | M90         |                 |                 |          |         |        |        |       |       |      |       |       |     |       |       |
| AM18     | 3 1/2"<br>3 3/4"   | M90         | 41.95           | 27062           | 407.29   | 912330  | 4058.2 | 116.3  | 52.77 | 270.0 | 80.6 | 222.5 | 114.5 | 217 | 520.0 | 217.4 |
|          |                    | M95         |                 |                 |          |         |        |        |       |       |      |       |       |     |       |       |
| AM19     | 3 3/4"<br>4"       | M95<br>M100 | 47.99           | 30964           | 466.02   | 1043885 | 4643.4 | 139.7  | 63.37 | 288.0 | 89.7 | 234.3 | 121.0 | 223 | 544.0 | 232.0 |

Notes:

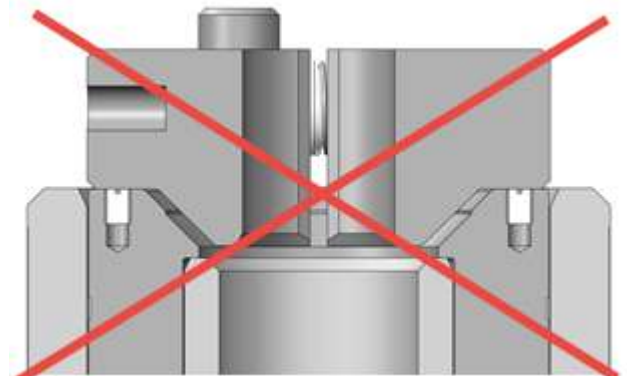
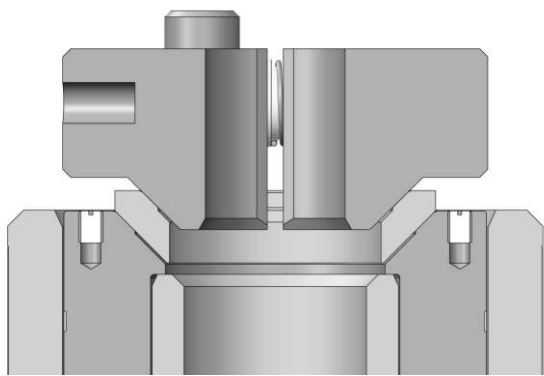
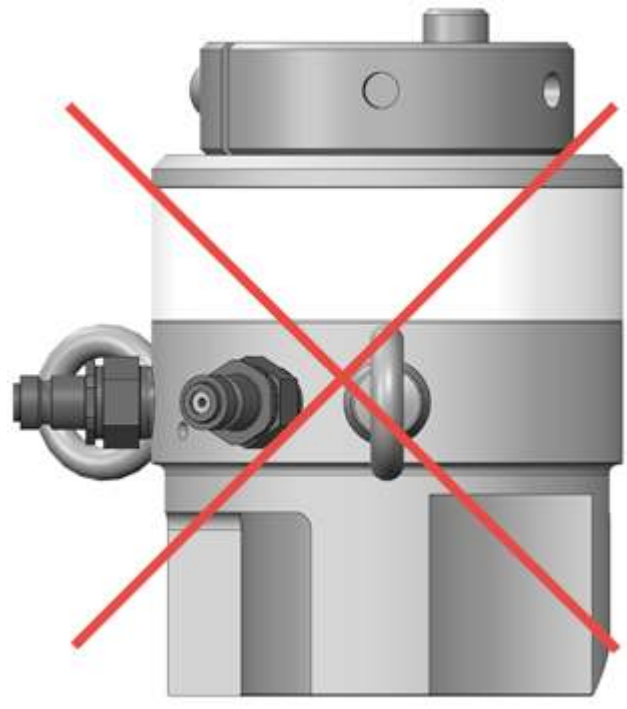
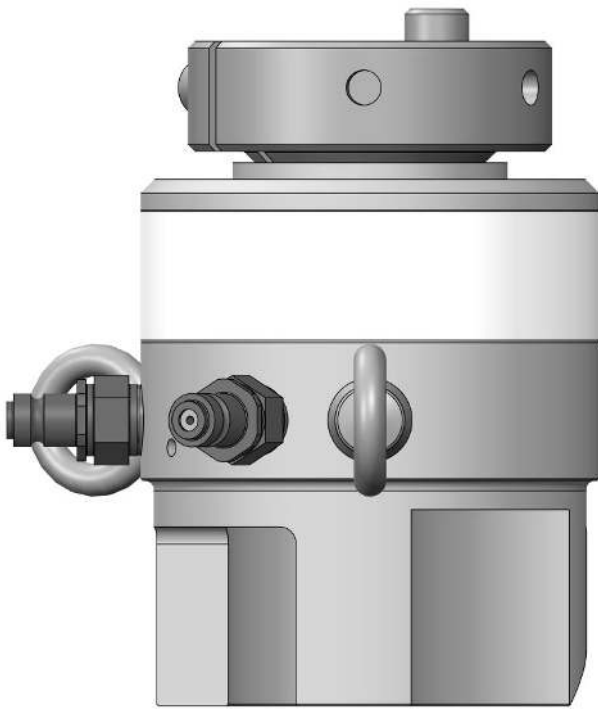
1. Maximum Working Pressure 1500 Bar (21750psi)
  2. All tools have 30mm stroke except AM01 and AM02 = 20mm
  3. Weight excludes Reaction Nut
  4. Eccentric shaped tool applies to AM01, AM02 and AM03.
  5. Tools forming the core range are AM03, AM05, AM07, AM09, AM11, AM13, AM15 & AM17
  6. Dimension "G" is measured on tool centreline.
  7. Product development is continually taking place and therefore certain dimensions could be subject to change.
- \* Requires Reaction Nut Step-Up Washer

### 3.2. STEP-UP WASHERS

The AquaMax® Tensioner must be used with a step-up washer for the following tool and bolt combinations to ensure the correct assembly.

Without the use of the correct step-up washer, tool failure will occur.

| Step-Up Washer | Tensioner Part Number | Tool Ref | Bolt Dia Imperial | Bolt Dia Metric |
|----------------|-----------------------|----------|-------------------|-----------------|
| C0307C0000XX   | C0400C0012AF          | AM03     | 3/4"              |                 |
|                | C0400C0014AF          |          | 7/8"              |                 |
|                | C0400CM020AY          |          |                   | M20             |
|                | C0400CM022AY          |          |                   | M22             |
| C0307D0000XX   | C0400E0100AF          | AM05     | 1"                |                 |
|                | C0400E0102AF          |          | 1.1/8"            |                 |
|                | C0400EM024AZ          |          |                   | M24             |
|                | C0400EM027AZ          |          |                   | M27             |
|                | C0400EM030BA          |          |                   | M30             |
| C0307E0000XX   | C0400G0104AF          | AM07     | 1.1/4"            |                 |
|                | C0400G0106AF          |          | 1.3/8"            |                 |
|                | C0400GM033BA          |          |                   | M33             |
|                | C0400GM036BB          |          |                   | M36             |
| C0307F0000XX   | C0400J0108AF          | AM09     | 1.1/2"            |                 |
|                | C0400J0110AF          |          | 1.5/8"            |                 |
|                | C0400JM039BB          |          |                   | M39             |
|                | C0400JM042BC          |          |                   | M42             |
| C0307G0000XX   | C0400N0112AF          | AM12     | 1.3/4"            |                 |
|                | C0400N0114AF          |          | 1.7/8"            |                 |
|                | C0400N0200AF          |          | 2"                |                 |
|                | C0400NM045BC          |          |                   | M45             |
|                | C0400NM048BD          |          |                   | M48             |
|                | C0400NM052BD          |          |                   | M52             |
| C0307H0000XX   | C0400R0204AF          | AM14     | 2.1/4"            |                 |
|                | C0400R0206AF          |          | 2.1/2"            |                 |
|                | C0400RM056BE          |          |                   | M56             |
|                | C0400RM060BE          |          |                   | M60             |
|                | C0400RM064BF          |          |                   | M64             |
| C0307J0000XX   | C0400T0212AF          | AM16     | 2.3/4"            |                 |
|                | C0400T0300AF          |          | 3"                |                 |
|                | C0400TM068BF          |          |                   | M68             |
|                | C0400TM072BF          |          |                   | M72             |
|                | C0400TM076BF          |          |                   | M76             |



**Figure 2a: STEP-UP WASHER USED**

**Figure 2b: NO STEP-UP WASHER**

### 3.3. PUMP REQUIREMENTS

This bolt tensioning equipment has been designed to be used in conjunction with a hydraulic pump unit. Hydratight can offer a range of pump options to suit particular applications and thus operators should refer to the specific instructions manual for the pump to be used. The safety rationale used in the design of this tensioner has assumed a pump maximum working pressure appropriate the tool and using hydraulic oil between ISO 22 and ISO 68. Hydraulic connection is made using quick disconnect male & female couplings. In the event an alternative pump unit is used, additional safety measures such as pressure relief valves or bursting discs must be considered to ensure over-pressurisation cannot occur.

The following are recommended pump parameters.

AIR SUPPLY                    1/2" nominal bore supply line

AIR CONSUMPTION        50 CFM

AIR PRESSURE             75 psi maximum

Refer to pump manual for operating instructions.

## 4. ASSEMBLY

### 4.1. APPLICATION PREPARATION

#### 4.1.1. HEXAGONAL NUT DRILLING DETAILS

In order to allow the rotation of the standard hexagonal nut, tommy bar holes are required to be drilled into the flat of each nut. Drilling details are shown below in Figure 3.

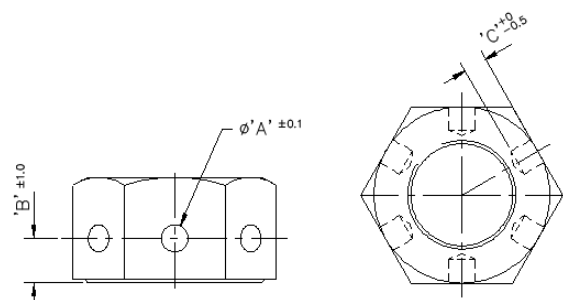
| HEXAGON NUT DRILLING – METRIC HEAVY SERIES |       |     |     |         |                    |
|--|-------|-----|-----|---------|--------------------|
| BOLT DIA.                                  | Ø 'A' | 'B' | 'C' | NUT A/F | TOMMY BAR DIAMETER |
|  | mm    | mm  | mm  | mm      |                    |
| M16  | 5.2   | 7   | 4*  | 24      | 5                  |
| M20  | 5.2   | 7   | 4*  | 30      | 5                  |
| M22  | 5.2   | 7   | 4*  | 32      | 5                  |
| M24  | 6.2   | 9   | 5*  | 36      | 6                  |
| M27  | 6.2   | 9   | 5*  | 41      | 6                  |
| M30  | 8.2   | 12  | 6*  | 46      | 8                  |
| M33  | 8.2   | 12  | 7*  | 50      | 8                  |
| M36  | 10.2  | 15  | 8*  | 55      | 10                 |
| M39  | 10.2  | 15  | 8   | 60      | 10                 |
| M42  | 10.2  | 15  | 9   | 65      | 10                 |
| M45  | 10.2  | 15  | 9   | 70      | 10                 |
| M48  | 12.4  | 18  | 11  | 75      | 12                 |
| M52  | 12.4  | 18  | 12  | 80      | 12                 |
| M56  | 14.4  | 21  | 12  | 85      | 14                 |
| M60  | 14.4  | 21  | 12  | 90      | 14                 |
| M64  | 16.4  | 24  | 14  | 95      | 16                 |
| M68  | 16.4  | 24  | 14  | 100     | 16                 |
| M72  | 16.4  | 24  | 14  | 105     | 16                 |
| M76  | 16.4  | 24  | 15  | 110     | 16                 |
| M80  | 16.4  | 30  | 15  | 115     | 16                 |
| M85  | 16.4  | 30  | 15  | 120     | 16                 |
| M90  | 16.4  | 30  | 18  | 130     | 16                 |
| M95  | 16.4  | 30  | 18  | 135     | 16                 |
| M100                                       | 16.4  | 30  | 18  | 145     | 16                 |

| HEXAGON NUT DRILLING – IMPERIAL HEAVY SERIES |       |     |     |          |                    |
|--|-------|-----|-----|----------|--------------------|
| BOLT DIA.                                    | Ø 'A' | 'B' | 'C' | NUT A/F  | TOMMY BAR DIAMETER |
|  | mm    | mm  | mm  | in       |                    |
| 5/8"   | 5.2   | 7   | 4*  | 1.1/16"  | 5                  |
| 3/4"   | 6.2   | 9   | 5*  | 1.1/4"   | 6                  |
| 7/8"   | 6.2   | 9   | 5*  | 1.7/16"  | 6                  |
| 1"   | 6.2   | 9   | 6*  | 1.5/8"   | 6                  |
| 1.1/8"                                       | 6.2   | 9   | 6*  | 1.13/16" | 6                  |
| 1.1/4"                                       | 8.2   | 12  | 8*  | 2"       | 8                  |
| 1.3/8"                                       | 8.2   | 12  | 8*  | 2.3/16"  | 8                  |
| 1.1/2"                                       | 10.2  | 15  | 9   | 2.3/8"   | 10                 |
| 1.5/8"                                       | 10.2  | 15  | 9   | 2.9/16"  | 10                 |
| 1.3/4"                                       | 10.2  | 15  | 10  | 2.3/4"   | 10                 |
| 1.7/8"                                       | 10.2  | 15  | 10  | 2.15/16" | 10                 |
| 2"   | 12.4  | 18  | 12  | 3.1/8"   | 12                 |
| 2.1/4"                                       | 12.4  | 18  | 12  | 3.1/2"   | 12                 |
| 2.1/2"                                       | 14.4  | 21  | 14  | 3.7/8"   | 14                 |
| 2.3/4"                                       | 14.4  | 21  | 14  | 4.1/4"   | 14                 |
| 3"   | 16.4  | 24  | 16  | 4.5/8"   | 16                 |
| 3.1/4"                                       | 16.4  | 24  | 17  | 5"       | 16                 |
| 3.1/2"                                       | 16.4  | 24  | 18  | 5.3/8"   | 16                 |
| 3 3/4"                                       | 16.4  | 24  | 18  | 5 3/4"   | 16                 |
| 4"   | 16.4  | 24  | 18  | 6 1/8"   | 16                 |

**Notes:**

1. The above tables are for use with imperial heavy series nuts and metric series hexagon nuts to ANSI B18.2.2 only. (Where the nut height = the stud diameter)
2. Dimension 'C' denotes maximum hole depth to drill point. Unless otherwise specified.

\* Indicates the use of a Flat Bottom Drill

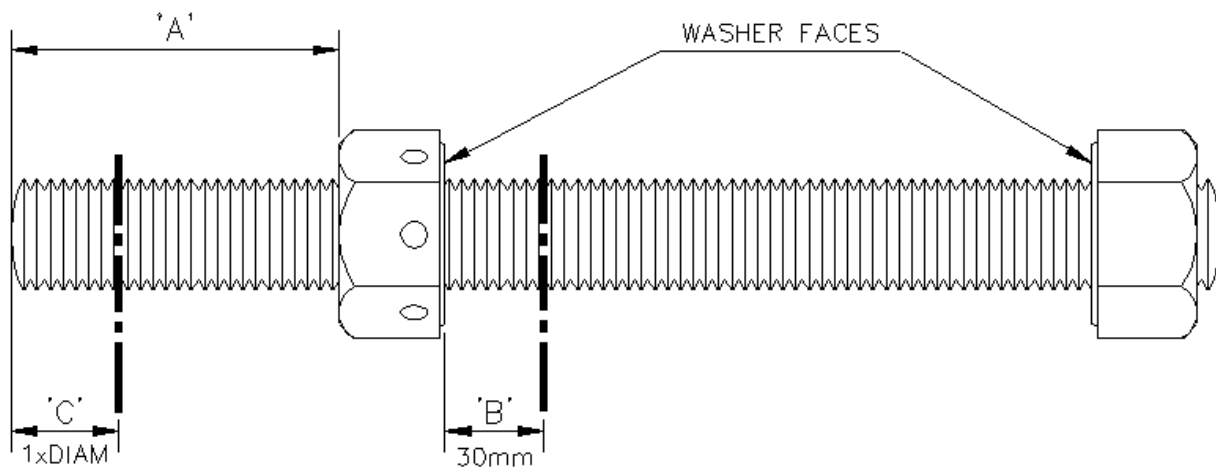


**Figure 3: DRILLED NUT**

**4.1.2. BOLT PREPARATION**

Simple bolt preparation, carried out topsides, will significantly reduce the risk of problems occurring during tensioner application and operation. Therefore, we would recommend that the following preparations and checks are adopted whenever possible.

- 4.1.2.1. To accommodate the AquaMax® tensioner an extended portion of bolt is required above the drilled hexagonal nut (Figure 4). It is recommended that this extension (length 'A') be pre-set before lowering the bolts underwater.
- 4.1.2.2. The required bolt protrusion must be through a drilled hexagonal nut and nut washer faces must point inwards. Visibly check that the nut drilled holes are nearest to the nut washer face.
- 4.1.2.3. The drilled hexagonal nut must be free-running on all bolts over the entire length 'A' and especially over the 30 mm length 'B' (Figure 4).
- 4.1.2.4. Assemble the Quick-Fastening reaction nuts to the end of the bolt protrusions, length 'C' (Figure 4), ensuring that the Quick-Fastening reaction nut locking mechanism fully and easily engages.  
Alternatively, if solid reaction nuts are used, ensure free running over bolt protrusion, length 'C'.
- 4.1.2.5. Protect the bolt protrusion using sleeves, adhesive tape, etc. This will not only protect the threads from knocks and damage during installation but prevent movement of the pre-drilled nut, which may alter the pre-set length 'A'.



**Figure 4: BOLT PREPARATION**

|                   |              |              |                  |                  |                  |                  |                  |                  |                  |                  |
|-------------------|--------------|--------------|------------------|------------------|------------------|------------------|------------------|------------------|------------------|------------------|
| <b>AquaMax® :</b> | <b>AM01</b>  | <b>AM02</b>  | <b>AM03</b>      | <b>AM04</b>      | <b>AM05</b>      | <b>AM06</b>      | <b>AM07</b>      | <b>AM08</b>      | <b>AM09</b>      | <b>AM10</b>      |
| <b>BOLT DIA</b>   | 3/4"         | 3/4"<br>7/8" | 7/8"<br>1"       | 1"<br>1 1/8"     | 1 1/8"<br>1 1/4" | 1 1/4"<br>1 3/8" | 1 3/8"<br>1 1/2" | 1 1/2"<br>1 5/8" | 1 5/8"<br>1 3/4" | 1 3/4"<br>1 7/8" |
| <b>LENGTH 'A'</b> | 101          | 101          | 128              | 129              | 134              | 128              | 137              | 144              | 154              | 149              |
| <b>AquaMax® :</b> | <b>AM11</b>  | <b>AM12</b>  | <b>AM13</b>      | <b>AM14</b>      | <b>AM15</b>      | <b>AM16</b>      | <b>AM17</b>      | <b>AM18</b>      | <b>AM19</b>      |                  |
| <b>BOLT DIA</b>   | 1 7/8"<br>2" | 2"<br>2 1/4" | 2 1/4"<br>2 1/2" | 2 1/2"<br>2 3/4" | 2 3/4"<br>3"     | 3"<br>3 1/4"     | 3 1/4"<br>3 1/2" | 3 1/2"<br>3 3/4" | 3 3/4"<br>4"     |                  |
| <b>LENGTH 'A'</b> | 147          | 156          | 154              | 164              | 173              | 184              | 180              | 217              | 223              |                  |

### 4.1.3. FLANGE AND BOLT ASSEMBLY

Prior to installation of the flange bolts, it is recommended that the flange is squared and brought into close contact using methods such as the Hydratight flange puller. Once the flange faces are square and in close proximity the bolts and gasket may then be installed.

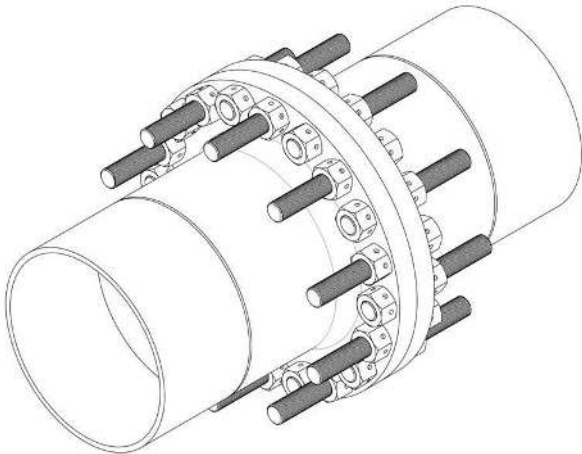
The bolts must be installed in a specific manner depending upon whether 100% tensioner coverage or 50% coverage is adopted.

#### 4.1.3.1. BOLT INSTALLATION FOR 100% TENSIONER COVERAGE (Figure 5a)

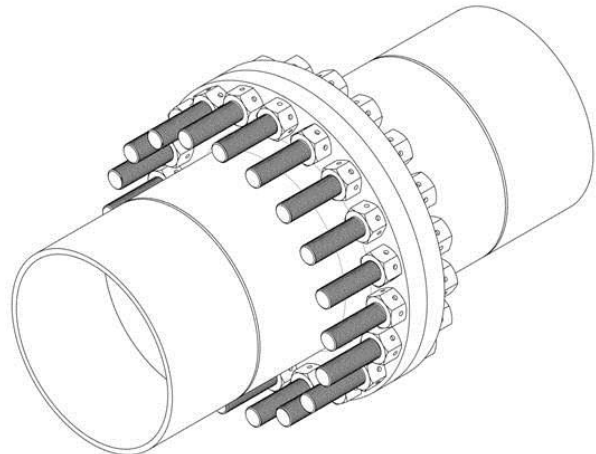
Using this method of assembly all bolts are tensioned in one operation. In order to achieve this, the bolts must be assembled with the thread protrusions staggered over each side of the flanged joint as illustrated in Figure 5a.

#### 4.1.3.2. BOLT INSTALLATION FOR 50% TENSIONER COVERAGE (Figure 5b)

This method of installation is normally used where bolts are required to be tensioned from one side of the flange only, due to an access restriction on the opposite. It is basically a two stage tensioning operation where 50% of the bolts are tensioned in the first stage, followed by the remaining 50% of bolts in the second stage. In order to adopt this method the bolts must be assembled with the protrusions on the same side of the flange as illustrated in Figure 5b.



**Figure 5a:**  
**100% TENSIONER COVER**



**Figure 5b:**  
**50% TENSIONER COVER**



## 4.2. TENSIONING TOOL ASSEMBLY

### 4.2.1. ASSEMBLING THE AQUAMAX® TENSIONERS

*NOTE: If de-tensioning, refer to Section 5.3.*

- 4.2.1.1.** Ensure that all rams are fully retracted, i.e. rams flush with the top of the body.
- 4.2.1.2.** Assemble one tensioner onto every bolt (every other bolt for 50% coverage) by sliding them over the bolt protrusions.
- 4.2.1.3.** Slide the Quick-Fastening reaction nut over the remaining bolt thread protrusion, tapered side toward the AquaMax®, and squeeze the nut halves together until the locking mechanism engages.
- 4.2.1.4.** Whilst supporting the weight of the tool, if located horizontally, and ensuring the bridge access window points radially outward, using a Tommy bar, screw the Quick-Fastening reaction nut down until it firmly seats against the ram taper. Do not advance the ram to the Quick-Fastening reaction nut as this does not ensure correct engagement. This, in effect, will centralise the assembly, retain the AquaMax® and lock the Quick-Fastening reaction nut in position.

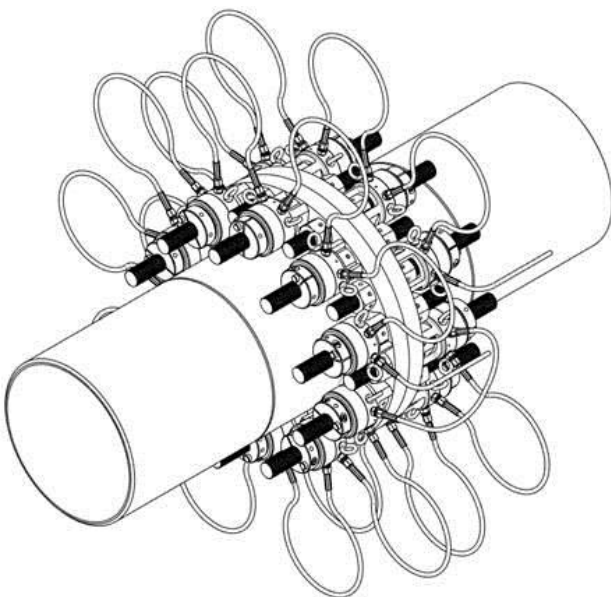
*NOTE: If solid reaction nuts are used, ensure that they do not bind on the bolt threads causing the bolt to turn through the hexagonal nut on the opposite side of the flange. Should this occur, then upon application of tensioning load, insufficient thread engagement may exist and could lead to stripping of the bolt threads.*

- 4.2.1.5.** The AquaMax® Tensioners are now assembled, ready for hose connection.

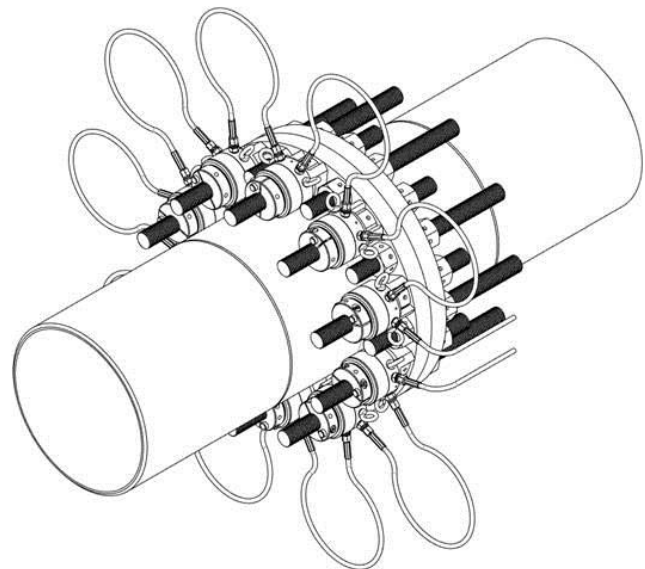
## 4.3. HOSE CONNECTION

Due to the AquaMax® Tensioner coupling arrangement, hose connection is very simple as shown below.

- 4.3.1.** Figure 6a illustrates a typical harness assembly for 100% tensioner coverage).
- 4.3.2.** Figure 6b illustrates a typical harness assembly for 50% tensioner coverage).



**Figure 6a:**  
**100% TENSIONER COVERAGE**



**Figure 6b:**  
**50% TENSIONER COVERAGE**

### 4.3.3. HOSE CONNECTION NOTES

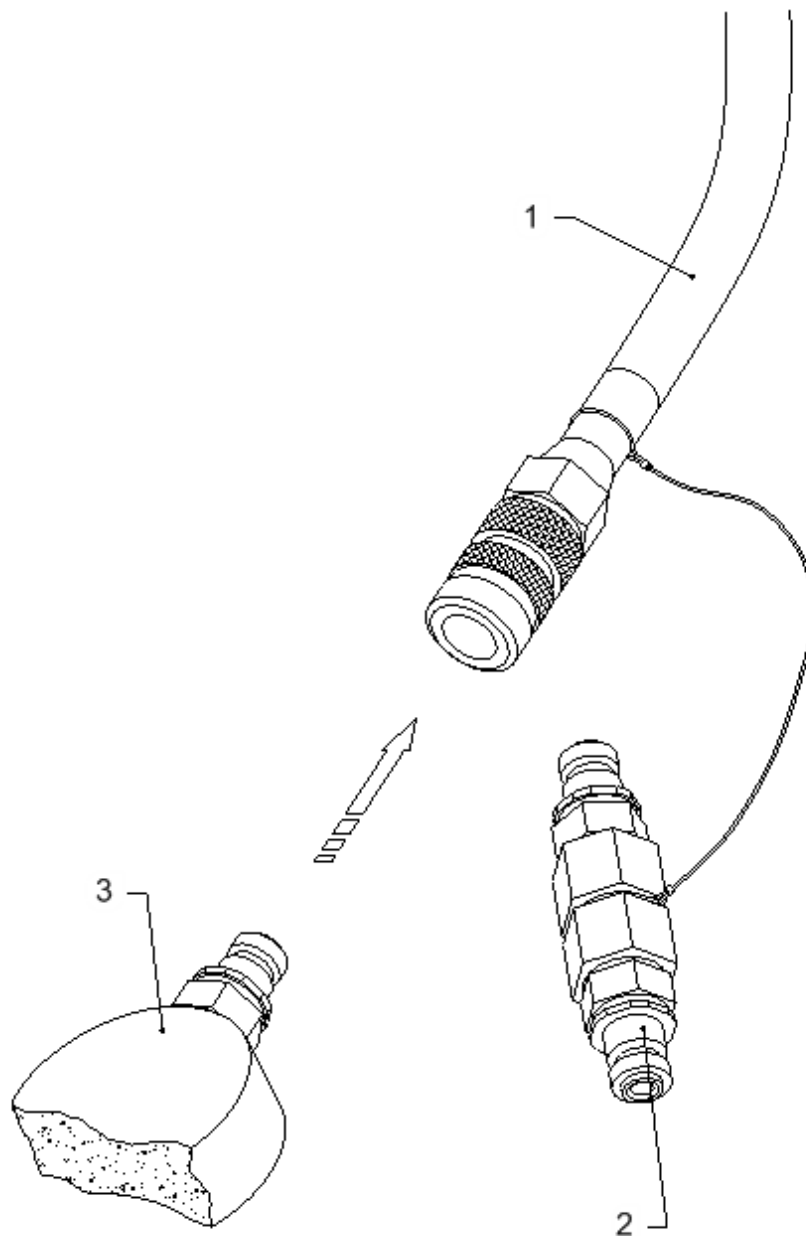
- 4.3.3.1.** Ensure the pump hydraulic oil return valve is fully open.
- 4.3.3.2.** Always connect the tensioners together working either in a clockwise or anti clockwise direction around the flange. This will minimise incorrect connections.
- 4.3.3.3.** For 100% tensioner coverage ensure that a link hose connecting tensioners on one side of the flange to the other exists. (Refer to Figure 6a).
- 4.3.3.4.** Both feed hoses must always be used with the downline manifold.
- 4.3.3.5.** The female quick disconnect coupling on downline hoses only, are equipped with locking collars which when screwed up behind the coupling sleeve prevents disengagement. The locking collar on the end of the downline must be backed off before the downline hoses can be disconnected.
- 4.3.3.6.** Should an interconnecting or feed hose be missing or damaged then the downline is equipped with a 'sacrificial hose' which is connected between the manifold and the end of the downline. This may be disconnected, the manifold re-connected to the end of the downline and the sacrificial hose used to replace the damaged or missing hose.

*NOTE: After removing the sacrificial hose, before the downline (Figure 7-1) can be re-connected to the downline manifold (Figure 7-3), the adaptor coupling (Figure 7-2) (chained to the end of the downline) must first be disconnected.*

- 4.3.3.7.** All hoses are fitted with self-sealing quick disconnect couplings ensuring that hydraulic fluid will not flow through the coupling unless fully connected. Therefore it is extremely important to check for complete coupling connection prior to pressurisation of the system.
- 4.3.3.8.** Ensure that the hoses are free of obstructions and do not cross such that upon pressurisation, detrimental loads will be induced on the connectors and adaptors potentially leading to failure.
- 4.3.3.9.** Quick-disconnect couplings are susceptible to knocks and damage therefore, take care when handling the equipment. A damaged coupling may prove very difficult to connect.

Should any of the quick disconnect couplings prove difficult to fully assemble, then it may be due to the following:

- a) Damage to the coupling
- b) Internal pressure within the AquaMax<sup>®</sup> due to over tightening the reaction nut during assembly. In such a case, the reaction nut must be released, the hose connected, and the reaction nut re-tightened.
- c) Internal pressure within the hose itself caused by previous use at a greater depth. This may be remedied by returning the hose to the surface and venting the internal pressure as described in Section 6.2.



**Figure 7: DOWNLINE ADAPTOR COUPLING**

#### **4.3.4. HOSE CONNECTION – RESTRICTED ACCESS**

##### **4.3.4.1. BANJO ASSEMBLIES**

In certain situations, where access is restricted, it may not be possible to attach the hydraulic hoses to the tensioner as shown, in Figures 6a and 6b. In such situations, it may be necessary to attach the hoses at 90° to that shown. This is achieved using banjo assemblies. Reference must be made to Section 6.5 for instructions regarding the assembly of these fittings onto the tools.

##### **4.3.4.2. ELBOW COUPLINGS**

Should difficulty be experienced in routing interconnecting hoses due to space restrictions such as overhead pipes, etc. then included in the standard accessory kit are elbow couplings which can quickly be assembled onto the hose allowing the hose to be directed axially rather than radially outward.

## 5. OPERATING PROCEDURES

### 5.1. AQUAMAX<sup>®</sup> BOLT TENSIONING PROCEDURE – 100% TOOL COVER

#### 5.1.1. SCOPE

This is a general tightening procedure for use with AquaMax<sup>®</sup> type bolt tensioners for the tension tightening of standard pressure containing flanged joints fitted with standard gaskets. (i.e. Spiral Wound, RTJ, CAF, etc.). The procedure has been compiled to accurately and efficiently achieve a pre-determined residual bolt stress.

#### 5.1.2. PRE-REQUISITES

The Client must be satisfied that:

- 5.1.2.1. Risk to personnel and assets have been assessed and all necessary safety precautions are being carried out.
- 5.1.2.2. The Client must approve this procedure prior to commencement of work
- 5.1.2.3. All personnel employed in using this procedure are competent and trained in the use of the equipment and joint tightening procedures
- 5.1.2.4. Tensioning pressures to be used are those as recommended or compiled by Hydratight.

#### 5.1.3. PROCEDURE

For each flange/joint to be tensioned refer to Hydratight's Informate Software (details can be found at hydratight.com). In order to correctly apply this required residual bolt load a controlled tensioning procedure must be adopted.

- 5.1.3.1. Ensure that the gap between the flange faces is uniform around the entire perimeter.
- 5.1.3.2. Assemble the tensioners and harness as per Section 4.3. Obtain final confirmation from the diver at the work site that he is satisfied with the set-up and ready for pressurisation to begin.
- 5.1.3.3. Apply a nominal hydraulic tool pressure of 1000 psi. Check tensioners for squareness and centralisation. Ensure reaction nuts are firmly engaged.
- 5.1.3.4. Apply the hydraulic tool pressure as specified on the 'Subsea Bolt Tensioning Data Sheet', and check to ensure that all rams project from the tensioner body. Turn down the pre-drilled hexagonal nuts within the tensioner bridge window using a tommy bar (whilst tensioners are under pressure), firmly seating each nut against the flange surface.

*NOTE: If both 1<sup>st</sup> and 2<sup>nd</sup> Pass pressures (A and B) are listed, the 1<sup>st</sup> Pass pressure should be ignored when adopting 100% tool coverage.*

*Do not use intermediate hydraulic tool pressures as this may interfere with the primary overstroke elimination feature (see Section 5.5)*

- 5.1.3.5. Release the system pressure and reapply the hydraulic pressure twice further, i.e. apply pressure and turn down nuts three times.
- 5.1.3.6. As a final check, ensure the gap between the flange faces is still uniform, apply the hydraulic tool pressure once more and attempt to further tighten the flange nuts. If the nuts cannot be turned then tensioning is complete and the system may be depressurised and the tensioners removed.
- 5.1.3.7. If the nuts can be turned, then reapply and release the tool pressure until the nuts cannot be rotated any further. Should repeated cycling be necessary, check that the correct grade of bolt/nut is being used.

The above tensioning procedure is typical only. Should the operator wish to adopt their own 'tried and tested' subsea tensioning procedures with the AquaMax<sup>®</sup> equipment, then Hydratight will be pleased to advise accordingly.

## 5.2. AQUAMAX<sup>®</sup> BOLT TENSIONING PROCEDURE – 50% TOOL COVER

### 5.2.1. SCOPE

This is a general tightening procedure for use with AquaMax<sup>®</sup> type bolt tensioners for the tension tightening of standard pressure containing flanged joints fitted with standard gaskets. (i.e. Spiral Wound, RTJ, CAF, etc.). The procedure has been compiled to accurately and efficiently achieve a pre-determined residual bolt stress.

### 5.2.2. PRE-REQUISITES

The Client must be satisfied that:

- 5.2.2.1. Risk to personnel and assets have been assessed and all necessary safety precautions are being carried out.
- 5.2.2.2. The Client must approve this procedure prior to commencement of work
- 5.2.2.3. All personnel employed in using this procedure are competent and trained in the use of the equipment and joint tightening procedures
- 5.2.2.4. Tensioning pressures to be used are those as recommended or compiled by Hydratight.

### 5.2.3. PROCEDURE

For each flange/joint to be tensioned refer to Hydratight's Informate Software (details can be found at hydratight.com). In order to correctly apply this required residual bolt load a controlled tensioning procedure must be adopted.

- 5.2.3.1. Ensure that the gap between the flange faces is uniform around the entire perimeter.
- 5.2.3.2. Assemble the tensioners and harness to the first 50% of the bolts as per Section 4.3. Obtain final confirmation from the diver at the work site that he is satisfied with the set-up and ready for pressurisation to begin.
- 5.2.3.3. Apply a nominal hydraulic tool pressure of 1000 psi. Check tensioners for squareness and centralisation. Ensure reaction nuts are firmly engaged.
- 5.2.3.4. Apply the 1<sup>st</sup> Pass pressure (Pressure A) as specified on the 'Subsea Bolt Tensioning Data Sheet' and check to ensure that all rams project from the tensioner body. Turn down ALL of the pre-drilled hexagonal nuts, including those without a tensioner fitted, using a tommy bar whilst maintaining the tensioner pressure. Firmly seat each nut against the flange surface.

*NOTE: Do not use intermediate hydraulic tool pressures as this may interfere with the primary overstroke elimination feature (see Section 5.5)*

- 5.2.3.5. Release the system pressure and reapply the 1<sup>st</sup> Pass pressure twice further, i.e. apply the 1<sup>st</sup> Pass pressure and turn down nuts three times.

*NOTE: At this stage, if the rams have advanced more than 3/4 of their maximum stroke due to pulling in the joint, then the tensioners must be manually retracted by screwing down the reaction nut using a tommy bar.*

- 5.2.3.6. Transfer the tensioning tools to the remaining 50% of the bolts and apply a nominal hydraulic tool pressure of 1000 psi. Check the tensioners for squareness and centralisation. Ensure the reaction nuts are firmly engaged.
- 5.2.3.7. Apply the 2<sup>nd</sup> Pass pressure (Pressure B) as specified on the 'Subsea Bolt Tensioning

Data Sheet' and check to ensure that all rams project from the tensioner body. Turn down the pre-drilled hexagonal nuts using a tommy bar whilst maintaining the tensioner pressure, firmly seating each nut against the flange surface.

- 5.2.3.8.** Release the system pressure and reapply the 2<sup>nd</sup> Pass pressure twice further, i.e. apply 2<sup>nd</sup> Pass pressure and turn down nuts three times.
- 5.2.3.9.** As a final check, reassemble the tensioners to the initial 50% of the bolts.
- 5.2.3.10.** Ensuring that the gap between the flange faces is still uniform, apply the 2<sup>nd</sup> Pass hydraulic tool pressure and attempt to further tighten the pre-drilled nuts using a tommy bar. If the nuts cannot be turned then tensioning is complete and the system may be depressurised and the tensioners removed.
- If the nuts can be turned then re-apply the 2<sup>nd</sup> Pass hydraulic tool pressure and turn down the pre-drilled hexagon nuts twice further.
- 5.2.3.11.** Transfer the tensioners to the remaining 50% of the bolts and apply the 2<sup>nd</sup> Pass hydraulic tool pressure and attempt to further tighten the pre-drilled nuts using a tommy bar. If the nuts cannot be turned then tensioning is complete and the system may be depressurised and the tensioners removed.
- 5.2.3.12.** If the nuts can be turned then re-apply and release the 2<sup>nd</sup> Pass pressure until the nuts cannot be rotated any further. Should repeated cycling be necessary, check that the correct grade of stud bolt/nut is being used.

The above tensioning procedure is typical only. Should the operator wish to adopt their own 'tried and tested' subsea tensioning procedures with the AquaMax<sup>®</sup> equipment, then Hydratight will be pleased to advise accordingly.

### 5.3. AQUAMAX<sup>®</sup> BOLT DE-TENSIONING PROCEDURE

A hydraulic tool pressure for de-tensioning is not normally provided as it is not always possible to predict the pressure at which the nut will break free. However, it is beneficial to be aware of the original 'make-up' tensioning pressure before the de-tensioning procedure is carried out as generally, the de-tensioning pressure is marginally higher than the original make-up pressure.

A general subsea de-tensioning procedure is described below.

- 5.3.1.1.** Pre-set the pump to the maximum allowable working pressure for the fastener in question. Note: Do not exceed the maximum working pressure of the tools 21750 psi (1500 bar).
- 5.3.1.2.** Before lowering the tensioners underwater; advance the ram of each tool approximately 10 mm.
- 5.3.1.3.** Assemble the tensioners and harness as per Section 4.3. Obtain final confirmation from the diver at the work site that he is satisfied with the set-up and ready for pressurisation to begin.
- 5.3.1.4.** With the tensioners assembled and the hydraulic harness connected, apply a nominal hydraulic tool pressure of 1000psi. Check the tensioners for squareness and centralisation. Ensure the reaction nuts are firmly engaged.
- 5.3.1.5.** Insert the tommy bar into the pre-drilled hexagon nuts. Increase the hydraulic pressure to the system. As the pressure builds attempt to loosen the nut, as soon as it turns, stop pressuring. (This pressure is normally slightly higher than the make-up tensioning pressure).
- 5.3.1.6.** Turn back each pre-drilled nut two complete turns i.e. 12 flats.
- 5.3.1.7.** Depressurise the system and remove the tensioners

## 5.4. RAM RETRACTION

The AquaMax<sup>®</sup> tensioner ram must be retracted if:

- a) The maximum ram stroke indicator becomes visible (the stroke indicator is in the form of a yellow band marked around the periphery of the ram).
- b) The operator is unsure of the maximum ram stroke.
- c) The operator would like to ensure that maximum stroke is available.

Under normal circumstances ram retraction will only be carried out during post-use maintenance, as the ram stroke available is more than adequate for most subsea tensioning operations. However, occasionally the AquaMax<sup>®</sup> may be required to be retracted during subsea tensioning, particularly where long strokes are used to close joints or if the two pass tensioning procedure is adopted (50% tensioner coverage).

### 5.4.1. RAM RETRACTION SUBSEA

**5.4.1.1.** Prior to opening the pump hydraulic oil return valve, turn down the pre-drilled nuts within the bridge window. This will prevent the joint from re-opening as the pressure is released.

*NOTE: When attempting to turn down the pre-drilled nuts, should one or two of the nuts be locked onto the underside of the tensioner (due to overstroking, see Section 5.5), do not attempt to release the locked nuts but simply turn down the remaining 'free' nuts. The locked nuts will become free when the system pressure is released and can then be turned down.*

*Should all, or the majority, of the pre-drilled nuts be locked onto the underside of the tensioner, then momentarily open, then shut the pump hydraulic oil return valve until the nuts become free and can then be turned down.*

**5.4.1.2.** Depressurise the system and ensure the pump hydraulic oil return valve is FULLY open.

**5.4.1.3.** Screw down the reaction nuts, using a tommy bar if necessary, until all rams are fully retracted.

### 5.4.2. RAM RETRACTION TOPSIDE

Refer to Section 6.2 'Post Use Maintenance'.

## 5.5. USING THE OVERSTROKE ELIMINATION DEVICE

The AquaMax<sup>®</sup> tensioner has been purposely designed with a long ram stroke to ensure that the majority of tensioning operations can be completed without the fear of the ram overstroking.

Overstroking the ram can be dangerous and injury may occur by the high pressure oil released from the tensioner as the ram is ejected from the cylinder.

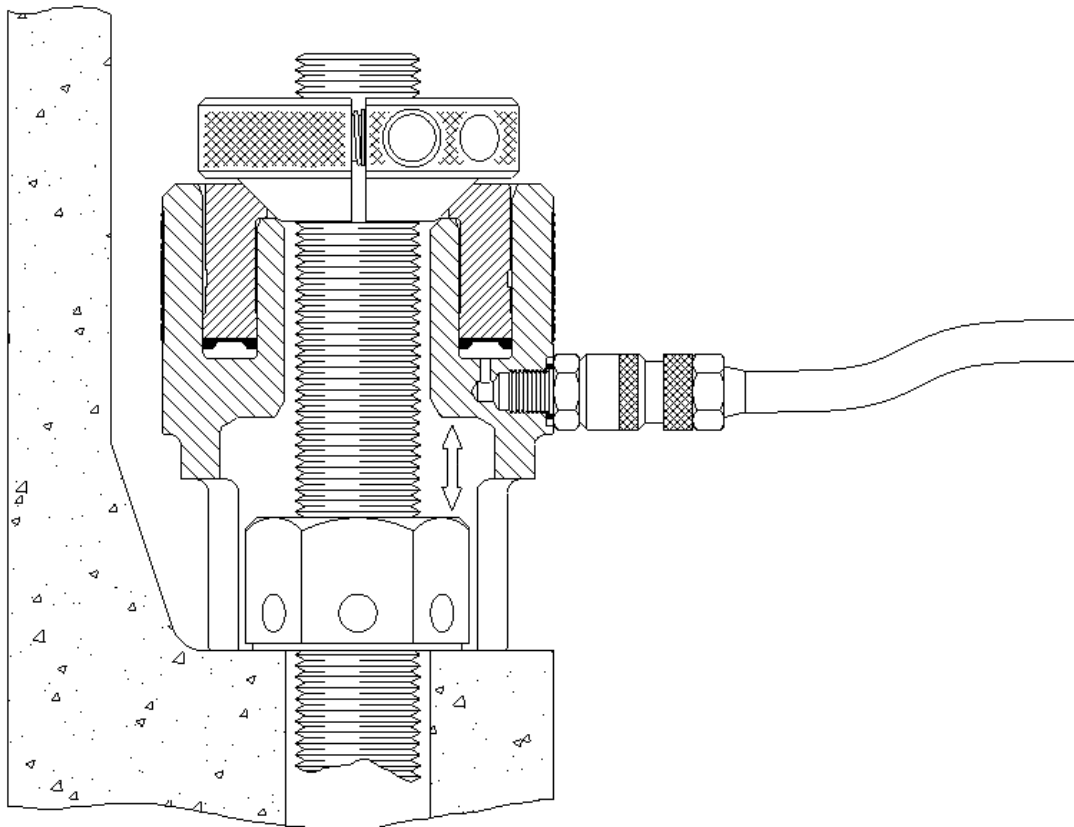
The AquaMax<sup>®</sup> tensioner possesses two safety features to counteract this dangerous situation. However, it must be stressed that ram overstroke will not be encountered if the ram stroke is continually monitored, the moment that the maximum stroke indicator band becomes visible, the pump stopped and the rams retracted.

### 5.5.1. PRIMARY OVERSTROKE ELIMINATION (NO OIL SPILL)

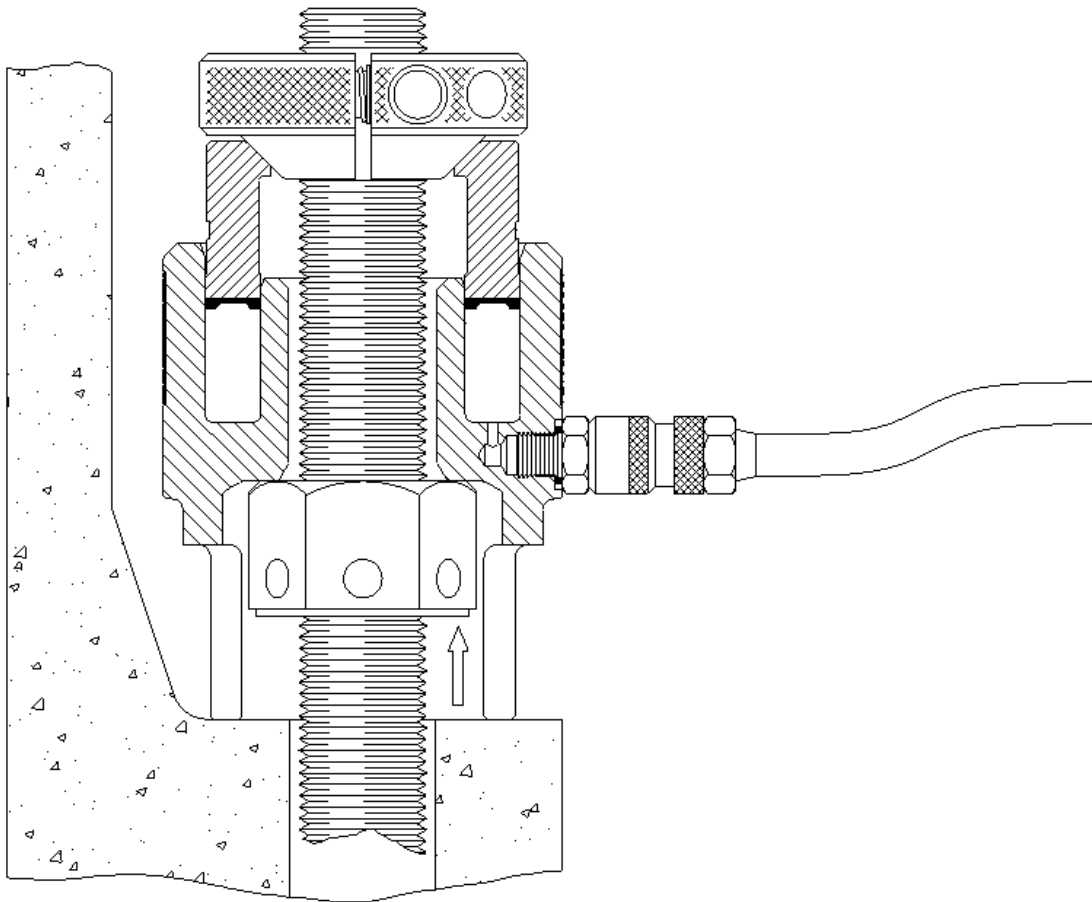
This is the main overstroke elimination feature which utilises the standard pre-drilled hexagonal nut for operation. As the AquaMax<sup>®</sup> operates, the pre-drilled nut lifts from the flange surface at a proportional rate to the ram stroke. As the ram approaches its maximum stroke, the top surface of the pre-drilled nut will contact the underside of the tensioner body, preventing further movement of the ram. At this point the maximum stroke indicator will be clearly visible and the rams must be retracted, as described in Section 5.4. Figure 8 illustrates the system.

*NOTE: The above primary overstroke eliminator will only operate if the following parameters are met.*

- a) The pre-drilled hexagonal nuts must be of standard heavy series form, i.e. nut height equal to one bolt diameter. Nut heights less than one bolt diameter may still be tensioned but primary overstroke elimination will not be operative.*
- b) The pre-drilled nuts must not be turned down until the pre-determined hydraulic pressure has been reached. Neither should they be turned down whilst the system is building up pressure, nor at intermediate pressures such as half pressure, three quarters pressure, etc.*
- c) Prior to tensioning, rams must be fully retracted and the reaction nuts firmly seated.*







**Figure 8: PRIMARY OVERSTROKE ELIMINATION**

### 5.5.2. SECONDARY OVERSTROKE ELIMINATION

Should the above parameters not be met, i.e. nut heights less than one bolt diameter or nuts required to be intermediately turned down, then the secondary overstroke elimination device will operate, should the ram exceed its maximum stroke.

If the maximum stroke is exceeded, the ram will become free of the cylinder and the high pressure oil will be safely released internally. This feature is only included as a fail-safe safety measure and is not intended to be used continually, as hydraulic seal damage will occur when the high pressure oil is released, rendering the AquaMax<sup>®</sup> inoperative. Although the suspect AquaMax<sup>®</sup> will require removal and replacement, this in comparison to a potentially injured operator is insignificant.

**NOTE:** *Should this feature operate, the ram will become free from the cylinder; therefore, before the AquaMax<sup>®</sup> is removed it is advisable to partially retract the ram by screwing down the reaction nut.*

## 6. MAINTENANCE

It is recommended that repairs and servicing be carried out by Hydratight at intervals agreed by Hydratight and customer. All parts will be thoroughly inspected and replaced where necessary, certain components (e.g. seals) will be replaced automatically. Tensioners will be re-assembled, pressure tested and a test certificate issued.

*NOTE: All parts will have been manufactured, inspected and tested in accordance with Hydratight's stringent requirements. Any parts failing in use that are found upon Hydratight's inspection not to be Hydratight's genuine spare parts will invalidate any operative warranty or guarantee.*

The tool is of rugged construction and utilises reliable seals. The only maintenance that may be occasionally required is the replacement of seals or repair of a hydraulic fitting.

*NOTE: It is strongly recommended that in the event of seal failure the tensioners are returned to Hydratight for seal replacement, however if this is not possible then the enclosed procedure should be followed.*

### 6.1. PRE-USE MAINTENANCE

- 6.1.1.1.** Assemble the tensioner onto a suitable bolt (see Section 4.2), check that the bolt material is capable of taking the applied load i.e. do not pressurise to max working pressure if the bolt is not strong enough to withstand the full load of the tool. Ram stroke should be minimised to prevent the overstroke eliminator valve being activated.
- 6.1.1.2.** Pressurise for approximately one minute, a pressure drop of 50 bar is acceptable during this time.
- 6.1.1.3.** If the tensioner passes this test, then the ram should be reset and the tensioner is ready for use.
- 6.1.1.4.** If any leakage is noticed within the head assembly, then a full strip down will be necessary to change the seals.

### 6.2. POST-USE MAINTENANCE

In order to keep the equipment in good working condition it is important that at the end of each operation a post-use maintenance is carried out.

#### 6.2.1. AQUAMAX<sup>®</sup> TENSIONERS

- 6.2.1.1.** Thoroughly rinse each AquaMax<sup>®</sup> under running fresh water (not sea water).
- 6.2.1.2.** Retract the rams by attaching open ended female quick-disconnects (supplied in the standard accessory kit) to the AquaMax<sup>®</sup> male inlets. With the AquaMax<sup>®</sup> standing on the ground and a suitable container positioned below the open ended couplings to catch the hydraulic fluid, push the ram back to its fully retracted position. The hydraulic fluid which has been bled from the tool during retraction must be discarded as it will be contaminated with sea water. It must NOT be returned into the pump unit hydraulic fluid reservoir.
- 6.2.1.3.** Coat each AquaMax<sup>®</sup> in a water repellent spray such as WD40 or similar. Alternatively rinse in light oil.
- 6.2.1.4.** If any leakage is noticed within the head assembly, then a full strip down will be necessary to change the seals.
- 6.2.1.5.** If tensioners are subject to a lot of use it is advisable to fully strip them and clean and inspect all components, at least once a year.

## 6.2.2. QUICK-FASTENING REACTION NUTS

- 6.2.2.1. Thoroughly rinse each Quick-Fastening reaction nut under running fresh water (not seawater) continuously operating the locking mechanisms to clear any debris which may have become lodged.
- 6.2.2.2. Coat each Quick-Fastening reaction nut in a water repellent spray such as WD40 or similar. Alternatively, rinse in light oil.

## 6.2.3. HOSES AND ANCILLARIES

- 6.2.3.1. Vent each interconnecting hose, feed hose, down line and manifold by connecting an open ended male quick-disconnect coupling (supplied in the standard accessory kit) into each female coupling. The couplings may be required to be forced together should internal pressure exist within the hoses resulting from being used at depth.

*NOTE: Any hydraulic fluid which has vented from the hoses must be discarded as it will be contaminated with seawater. It must NOT be returned into the pump unit hydraulic fluid reservoir.*

- 6.2.3.2. Coat each quick disconnect coupling in a water repellent spray such as WD40 or similar, retracting and releasing the collars several times. Ensure that the collars do not seize in the retracted position.

## 6.3. AQUAMAX<sup>®</sup> TENSIONER FULL MAINTENANCE / SERVICE

It is recommended that repairs and servicing be carried out by Hydratight at intervals agreed by Hydratight and customer. All parts will be thoroughly inspected, specified parts will be non-destructively tested using MPI techniques and replaced where necessary, certain components (e.g. seals) will be replaced automatically.

Tensioners will be re-assembled, pressure tested and a test certificate issued.

*NOTE: All parts will have been manufactured, inspected and tested in accordance with Hydratight's stringent requirements. Any parts failing in use that are found upon Hydratight's inspection not to be Hydratight's genuine spare parts will invalidate any operative warranty or guarantee.*

- 6.3.1. Inspect the tensioner for any visible damage/leaks etc.
- 6.3.2. Unscrew the quick disconnect couplings
- 6.3.3. Replace the seals as described below.
- 6.3.4. Refit the quick disconnect nipples.
- 6.3.5. Assemble the tensioner onto a bolt (see Section 4.2) check that the bolt material is capable of taking the applied load i.e. do not pressurise to max working pressure if the bolt is not strong enough to withstand the full load of the tool. Pressurise for approximately one minute, a pressure drop of 50 bar is acceptable during this time.
- 6.3.6. Having removed the tensioner from the bolt, coat each sub-assembly in a water repellent spray such as WD40 or similar.
- 6.3.7. Replace the dust caps on the quick disconnect couplings.

## 6.4. CHANGING THE SEALS

### 6.4.1. PRECAUTIONS

The following precautions must be taken with the assembly of the hydraulic seals:

- 6.4.1.1. Avoid sharp edges (cover thread areas)

**6.4.1.2.** Remove all dust, dirt, swarf and foreign particles.

**6.4.1.3.** Do not use sharp edged tools.

**6.4.1.4.** Lubricate all components before assembly.

Hydraulic seal replacement must only be carried out should the seals become damaged. The seals should not be removed during routine maintenance.

**6.4.2. RAM SEALS**

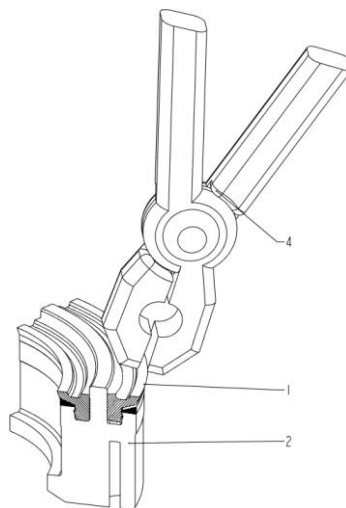
**6.4.2.1. LEGEND FOR FIGURES**

- 1. Seal
- 2. Ram
- 3. Anti-Extrusion Ring (AER)
- 4. Pliers
- 5. Blunt Edged Dolly

**6.4.3. SEAL REMOVAL**

**6.4.3.1.1.** Fit an open-ended female quick-disconnect coupling (supplied in the standard accessory kit) to a tensioner nipple. Remove the four plastic grub screws located in the ram surface, assemble four appropriate ram extraction bolts (supplied) into the threaded holes, and using these bolts, pull the ram free from the cylinder bore.

**6.4.3.1.2.** To remove the hydraulic seals and Anti-Extrusion Rings (AER's):  
Using a pair of pliers, grip the inner sealing lip of the hydraulic seal and pull the seal away from the ram. Take care not to damage the edge of the ram.



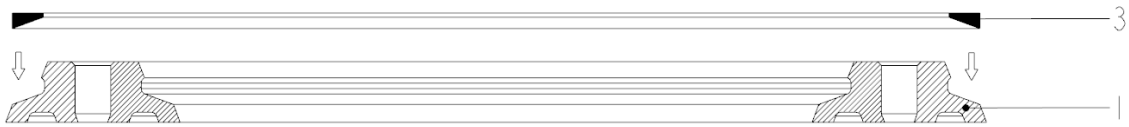
**Figure 9: REMOVAL OF SEALS**

**6.4.3.1.3.** Discard the seal, remove the extraction bolts and replace the four plastic grub screws.

**6.4.3.2. SEAL REPLACEMENT**

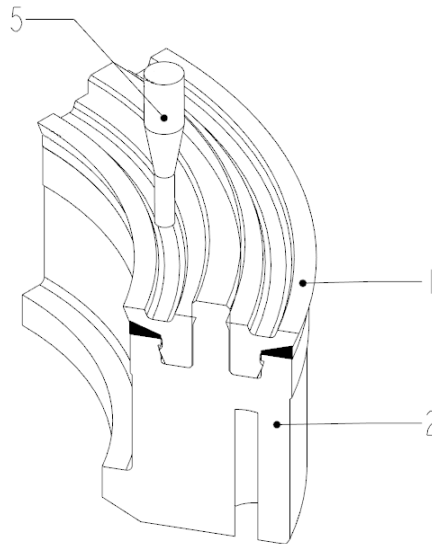
**6.4.3.2.1.** Inspect the seal housing grooves within the ram, ensuring that they are clean and free from debris.

**6.4.3.2.2.** Fit the AER's to the seal, the tapered surface of the AER must face the taper of the seal as shown below. This applies to both outer and inner AER's.



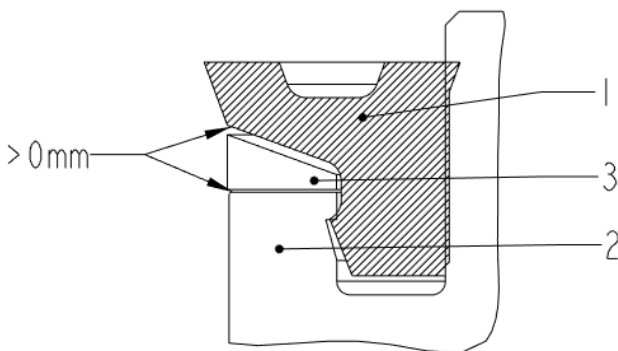
**Figure 10: AER LOCATION**

- 6.4.3.2.3. Install the seal assembly into the ram, pressing down firmly until the seal fully enters the ram seal housing.
- 6.4.3.2.4. Engage the seal retaining clip by pushing down around the periphery using a blunt edged dolly in the position shown below. A 'click' will be sensed when the seal fully engages.

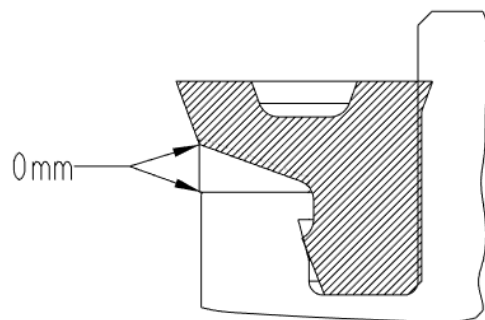


**Figure 11: ENGAGING THE SEAL**

- 6.4.3.2.5. When there are no gaps between the ram, AER and seal the assembly is correct, see below.



**Figure 12a:  
INCORRECT AER ASSEMBLY**



**Figure 12b:  
CORRECT AER ASSEMBLY**

- 6.4.3.2.6. Lubricate the seal and tensioner bores with silicone grease or clean hydraulic oil in preparation of installing the ram.
- 6.4.3.2.7. Push the ram into the cylinder bore ensuring that the seal does not become nipped. The outer seal will be the first to enter and can be used as a guide to square up the ram prior to entering the inner seal. Should difficulty be encountered in entering seals, a slight rotation of the ram whilst pushing the ram into the body may aid the installation

## 6.4.4. NIPPLE SEALS

### 6.4.4.1. 1/4" BSP FITTINGS

A simple sealing arrangement exists between the AquaMax<sup>®</sup> tensioner body and the nipple. The seal is a 1500 Bar rated Bonded Seal; it is located inside a counterbore on the tensioner body behind the nipple. Should the seal leak or become damaged then it should be replaced as follows.

6.4.4.1.1. Unscrew the male quick-disconnect nipple.

**NOTE:** *A 1/4" BSP threaded adaptor is fitted into the male quick-disconnect nipple. Under normal circumstances this will remain an integral part of the coupling and should not be removed. However, should the adaptor and nipple become separated or unscrewed, then the adaptor must be reassembled into the nipple and re-tightened. The 1/4" BSP adaptor must never be installed into the tensioner body before the nipple and seals are attached. Follow the procedure below if the adaptor has separated from the nipple.*

- a) *Clean the nipple thread and adaptor, removing all traces of debris.*
- b) *Coat the end of the adaptor which is to be screwed into the coupling (i.e. the end with the spigot and the female hexagon), with 'Loctite 270' and screw into the nipple until it is finger tight.*
- c) *Remove surplus 'Loctite'.*
- d) *Leave the assembly for a minimum of 30 minutes curing time before proceeding with assembly into the AquaMax<sup>®</sup> tensioner body.*

6.4.4.1.2. Remove and discard the bonded seal.

6.4.4.1.3. Clean any dirt and debris from the tensioner body counterbore and the nipple spigot face.

6.4.4.1.4. Insert a new bonded seal into the counterbore.

6.4.4.1.5. Lubricate the thread on the adaptor with Omega 95 (or similar lubricant with a coefficient of friction = 0.12), and tighten to a torque of 45 lbf.ft (61 Nm). Ensure that the bonded seal does not become nipped or dislodged during tightening.

### 6.4.4.2. 1/8" BSP FITTINGS

On AM01 tensioners the tools have 1/8" BSP ports. For these tools, a 1/4" BSP (male) x 1/8" BSP (male) adaptor is used between the nipple (1/4" BSP) and the AquaMax<sup>®</sup> tensioner body (1/8" BSP). Both ends of the adaptor are coned to create a metal to metal seal with mating components. Should the seal leak or become damaged then it should be replaced as follows.

6.4.4.2.1. Unscrew the nipple and adaptor from the tensioner body using the hexagon of the adaptor (not the nipple).

6.4.4.2.2. Clean any dirt and debris from the tensioner body counterbore and the sealing face on the adaptor.

6.4.4.2.3. Do not lubricate the 1/8" BSP thread on the adaptor it is important that the adaptor is installed dry to prevent overloading the threads: thread sealant should not be used.

6.4.4.2.4. Screw the adaptor into the tensioner body and tighten to a torque of 30-35 Nm (22-26 lb.ft).

**IMPORTANT NOTE:** *Care must be taken not to over tighten the adaptors into the tensioner and to use the hexagon on the adaptor to pull it in rather than the hexagon on the male quick disconnect coupling which could induce bending, leading to failure.*

## 6.5. ASSEMBLY OF BANJO FITTINGS

Banjo fittings are used as a method of re-orientating the quick disconnect couplings when access is difficult.

- 6.5.1. Remove the standard male quick disconnect coupling and associated adaptor from the tensioner.
- 6.5.2. The banjo block is fitted with a male quick disconnect coupling, 1/4" BSP adaptor and a bonded seal (or O-Ring seal with steel back up ring). If these items are not already fitted to the banjo block, then the block should be gripped in a soft jawed vice and the coupling / adaptor assembled in accordance with the instructions in Section 6.4.4.
- 6.5.3. Ensure that the tensioner body counterbore is clear of dirt and debris and insert a 1/8" or 1/4" bonded seal (or an O-Ring and back-up ring) as appropriate.
- 6.5.4. Insert a bonded seal (or an O-Ring and back-up ring) into the counterbore on the outside face of the banjo block.
- 6.5.5. The threads on the 1/4" banjo bolt should be coated with Omega 95 (or similar lubricant with a coefficient of friction = 0.12). The threads on the 1/8" banjo bolt should be assembled dry i.e. no lubricant. Insert the banjo bolt through the bore of the banjo block.
- 6.5.6. Insert the banjo bolt into the port on the tensioner body and when the banjo block is in the desired orientation, tighten to the following torque:

1/8" BSP: 35 lb.ft (47 Nm)

1/4" BSP: 45 lbf.ft (61 Nm)

## 7. TROUBLESHOOTING

| Fault   | Possible Cause  | Corrective Action  |
|---|---|--|
| Hoses difficult to assemble   | <ol style="list-style-type: none"> <li>1. Damaged coupling</li> <li>2. Coupling locking collars not fully screwed back</li> <li>3. Internal pressure in hose</li> </ol>   | <ol style="list-style-type: none"> <li>1. Replace coupling</li> <li>2. Screw back collars</li> <li>3. Vent hose</li> </ol>   |
| Oil is leaking from the hydraulic connection.   | Connection is not seating properly.   | Tighten the connection. Where applicable replace connection components.  |
| Pump does not operate   | <ol style="list-style-type: none"> <li>1. Air supply not connected</li> <li>2. Air regulator closed</li> <li>3. Start/stop valve closed</li> </ol>  | <ol style="list-style-type: none"> <li>1. Connect air supply</li> <li>2. Set air regulator</li> <li>3. Operate valve</li> </ol>  |
| Pump is not building pressure with oil return to tank valve closed.                           | <ol style="list-style-type: none"> <li>1. Oil return to tank valve may be defective.</li> <li>2. Check valve may be sticking inside the pump head.</li> </ol>   | <ol style="list-style-type: none"> <li>1. Replace the return to tank valve.</li> <li>2. Tap the pump head lightly with a hide hammer. If this fails the pump must be stripped down.</li> </ol>                             |
| Pump stalls prior to reaching required pressure   | <ol style="list-style-type: none"> <li>1. Insufficient air supply</li> <li>2. Air pressure regulator</li> </ol>   | <ol style="list-style-type: none"> <li>1. Increase air supply</li> <li>2. Adjust air regulator</li> </ol>  |
| Maximum pressure cannot be achieved, even when pump is running continuously                   | <ol style="list-style-type: none"> <li>1. Leaking couplings</li> <li>2. Leaking tensioner seals</li> <li>3. Hydraulic oil return valve</li> <li>4. Air in system</li> </ol>   | <ol style="list-style-type: none"> <li>1. Replace suspect couplings</li> <li>2. Replace suspect seals</li> <li>3. Fully close valve or replace</li> <li>4. Run pump for short period with oil return valve open</li> </ol> |
| Pump runs erratically/jerky after a period of time  | Foreign matter in hydraulic oil   | Renew hydraulic oil  |
| Pressure reading erratic  | Defective gauge   | Replace gauge  |
| Ram will not retract.   | <ol style="list-style-type: none"> <li>1. Oil return to tank valve is not open.</li> <li>2. Coupling not assembled</li> </ol>   | <ol style="list-style-type: none"> <li>1. Ensure that the oil return to tank valve is fully open.</li> <li>2. Check couplings</li> </ol>   |
| Rams do not stroke (with no gauge pressure build up)  | <ol style="list-style-type: none"> <li>1. Open pump hydraulic oil return valve</li> <li>2. Leaking/burst hose</li> <li>3. Leaking coupling/seals</li> <li>4. Leaking tensioner seals</li> <li>5. Defective pump unit</li> </ol> | <ol style="list-style-type: none"> <li>1. Close valve</li> <li>2. Replace hose</li> <li>3. Replace coupling/seals</li> <li>4. Replace seals</li> <li>5. Check pump for oil delivery</li> </ol>                             |
| Rams do not stroke (with gauge pressure build up)   | <ol style="list-style-type: none"> <li>1. Coupling not assembled</li> <li>2. Incorrect harness assembly</li> </ol>  | <ol style="list-style-type: none"> <li>1. Check couplings</li> <li>2. Check harness</li> </ol>   |
| When detensioning tool becomes locked onto the bolt.  | Tools not stroked prior to detensioning process   | Re-tension then follow procedure in Section 5.3  |
| The nut is not turning when the system is under pressure.                                     | <ol style="list-style-type: none"> <li>1. The hydraulic hose is not connected properly to the tool.</li> <li>2. The bolt thread may be damaged.</li> </ol>  | <ol style="list-style-type: none"> <li>1. Release the pressure and check the hose connection.</li> <li>2. Release the pressure, remove the tool and rectify.</li> </ol>  |
| Quick-Fastening reaction nut will not engage  | <ol style="list-style-type: none"> <li>1. Oversize bolts</li> <li>2. Differing thread form</li> </ol>   | <ol style="list-style-type: none"> <li>1. Check bolt size</li> <li>2. Check thread form</li> </ol>   |
| Hydraulic fluid visible at top/bottom of tensioner<br>Oil is leaking from the tensioner body. | <ol style="list-style-type: none"> <li>1. Maximum stroke achieved – Overstroke Eliminator valve activated (PS2 – PS8)</li> <li>2. Leaking tensioner seals</li> </ol>  | <ol style="list-style-type: none"> <li>1. Tighten nut and repeat procedure</li> <li>2. Replace seals</li> </ol>  |



## **8. EMERGENCY MEASURES**

### **8.1. STANDARD HEXAGONAL NUTS USED AS REACTION NUTS**

A standard hexagonal nut CANNOT be used as a direct replacement for a reaction nut. Damage WILL occur to the AquaMax® ram (and possibly the cylinder) if a hexagonal nut is used and any warranty or guarantee will be invalidated.

In instances where a reaction nut is lost or misplaced, then spare solid reaction nuts are included with the standard accessory kit and these should be used.

In cases of extreme emergency a standard hexagonal nut can be used PROVIDED that a thick washer, large enough in diameter to cover the entire ram surface, is fitted underneath the standard hexagonal 'reaction' nut.

## **9. STORAGE AND TRANSPORTATION OF EQUIPMENT**

### **9.1. STORAGE**

#### **9.1.1. AQUAMAX® TENSIONER**

- 9.1.1.1.** Store tools fully retracted.
- 9.1.1.2.** The finish will protect the tools from rust etc. but for added protection a light coating of oil or rust inhibitor should be applied to all plated surfaces.
- 9.1.1.3.** Cover the internal threads on the inside of the pullers with a rust inhibitor.
- 9.1.1.4.** Store tools upright.
- 9.1.1.5.** Keep dust caps on the oil inlet nipples.

#### **9.1.2. HYDRAULIC HARNESS AND HOSES**

- 9.1.2.1.** Wipe all hoses clean and apply a light coating of oil or suitable rust inhibitor to all nipples, couplings and tee blocks.
- 9.1.2.2.** Always keep dust caps fitted to nipples and couplings.

#### **9.1.3. PUMP UNIT**

- 9.1.3.1.** Always store the pump upright.
- 9.1.3.2.** Apply a light oil coating or suitable rust inhibitor to all exposed unplated metal items.
- 9.1.3.3.** Leave the oil return to tank valve in the open position.
- 9.1.3.4.** Leave the air control valve in the open position.
- 9.1.3.5.** Always keep dust caps on inlet and outlet hydraulic fittings.

### **9.2. TRANSPORTATION**

- 9.2.1.** Tools with a mass above 15 kg are fitted with lifting points.
- 9.2.2.** Tools with a mass below 15 kg are deemed acceptable for manual handling.

## **10. ANCILLARY/SPARE PARTS**

### **10.1. ANCILLARY EQUIPMENT**

#### **10.1.1. PUMP UNIT**

A high delivery air powered pump unit used to supply hydraulic oil to the AquaMax<sup>®</sup> tensioner.

#### **10.1.2. FEED HOSES**

3 metres long, used to connect pump unit to AquaMax<sup>®</sup> tensioners.

#### **10.1.3. INTERCONNECTING HOSE**

1 metre long, used to link the tensioners together constructing a ring main harness.

#### **10.1.4. DOWN LINE**

Made up in 30 metre lengths, used to connect the 'harness' to the topsides pump unit.

#### **10.1.5. HOSE REEL**

Used to carry the 30 metre lengths of downline.

#### **10.1.6. DOWNLINE MANIFOLD**

A 3 way manifold used to connect the downline to the tensioner harness.

#### **10.1.7. SACRIFICIAL HOSE**

A 3 metre feed hose connected between the downline and the downline manifold - used as an emergency replacement feed or interconnecting hose.

#### **10.1.8. DOWNLINE ADAPTOR COUPLING**

Used to connect the sacrificial hose to the downline.

#### **10.1.9. OPEN ENDED FEMALE QUICK-DISCONNECT COUPLING \***

Used for AquaMax<sup>®</sup> ram retraction

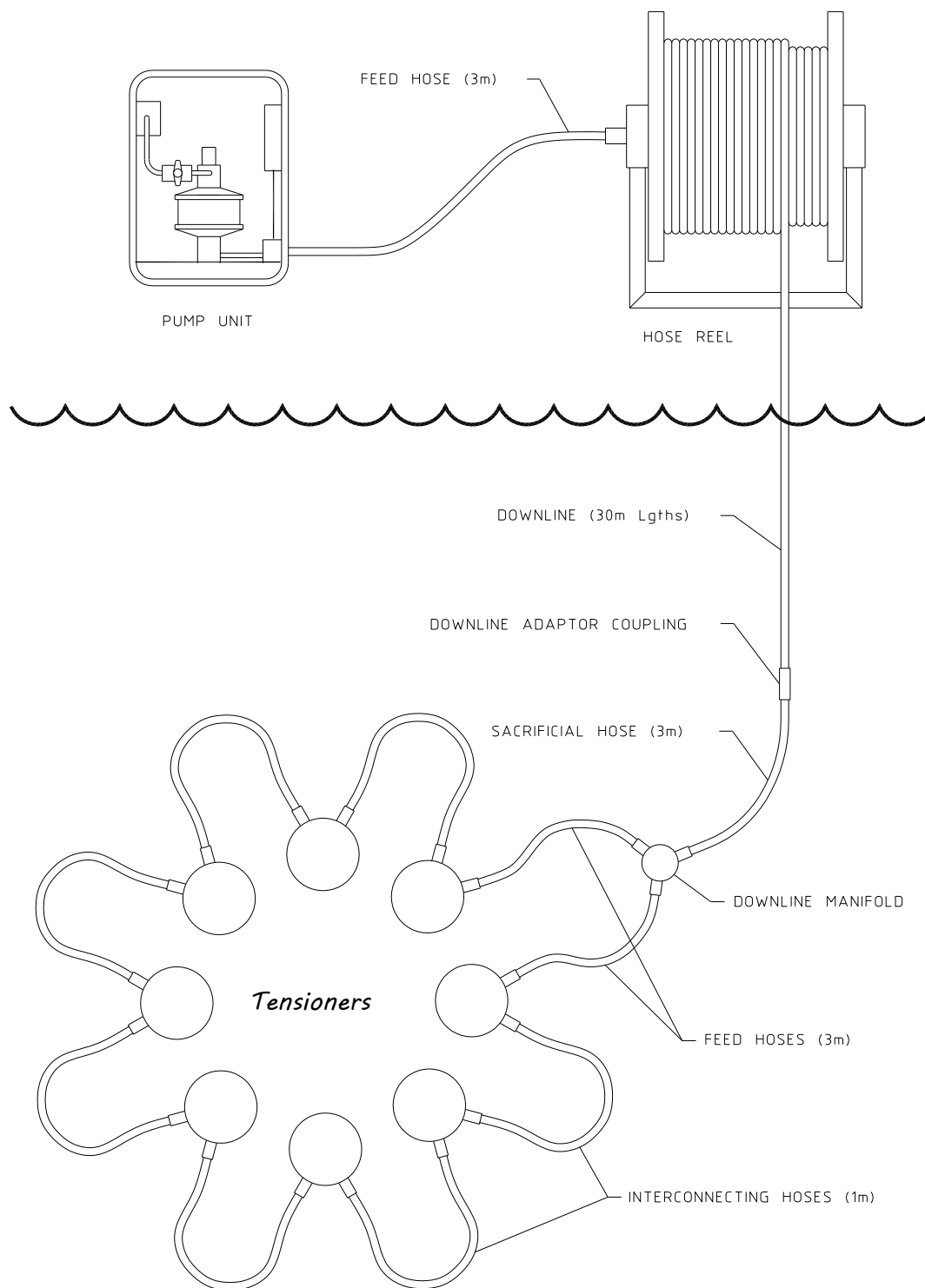
#### **10.1.10. OPEN ENDED MALE QUICK-DISCONNECT COUPLING \***

Used for hose venting following use at depth.

#### **10.1.11. BLANK FEMALE QUICK-DISCONNECT COUPLING\***

Used to blank the pump hydraulic oil outlets when pre-setting the pump hydraulic pressure.

\*Included in standard accessory kit.



**Figure 13: ARRANGEMENT OF ANCILLARY EQUIPMENT**

## 10.2. RECOMMENDED SPARES

- 2 off Open ended quick disconnect couplings
- 2 off Open ended quick disconnect nipples
- 2 off Blank female quick disconnect couplings
- 2 off Elbow couplings
- 2 off Ram Extraction Bolts
- 2 off Solid Reaction Nuts (for specific tensioner)
- Bonded Seals (1500 bar rated)
- Tensioner Seal Kit

## 10.3. SPARE PART ORDERING INFORMATION

The following information should be quoted when ordering spare parts.

- 10.3.1. The assembly name and Serial Number (Stamped on body – format: \*\*\*\*\*/\*\*OF\*\*)
- 10.3.2. The component name and part number (obtained from GA and parts list).
- 10.3.3. The contract number or approximate date the equipment was purchased.

## 11. APPROVED DISTRIBUTORS

All contacts details are available on <http://www.hydratight.com/en/contact-us>

## 12. TRAINING

Approved training courses for the operation of all our equipment are operated in our own training centre. Please contact our Training Department for further information.

## 13. REVISION HISTORY

| Rev No. | Date      | Description  | Author / Approver |
|---------|-----------|--|-------------------|
| AA      | 03-Oct-08 | Original Issue   | TOB / AT          |
| AB      | 12-Dec-08 | CJ18 & CJ19 added  | AT                |
| AC      | 28-Apr-10 | CN-7955 – CJ now AquaMax®  | LC / MH           |
| AD      | 09-Jul-15 | Various changes – See ECN - CE_Manual_Update   | GRM / MH          |
| AE      | 23-Oct-15 | Various Error references removed. Considered un-necessary.   | MH / GRM          |
| AF      | 09-Feb-16 | Detail of serial number location and format added to 'Spare Part Ordering Information'               | GRM / MH          |
| AG      | 14-Jun-16 | Step-up Washer data added – Section 3.2<br>2.2.4. updated to include BS4190<br>Registered Mark added | GRM / MH          |
| AH      | 12-Jul-16 | 2.2.4 clarified for metric heavy series  | GRM / MH          |

## **ANNEX 1. CE DECLARATION OF CONFORMITY**

We hereby certify that the above mentioned equipment complies with all the relevant provisions of the Directive listed below and the National Laws and Regulations adopting the Directive.

**The certification applies to the following Directive:**

2006/42/EC "Machinery Directive"

**The following harmonised standards have been used in the assessment process:**

ISO 12100 (Safety of Machines), ISO 4413 (Hydraulic fluid power)

**The equipment**

- There is no EC type examination applicable to the type of equipment at this time.
- There are no national or international technical standards wholly applicable to this type of equipment.
- There are no transposed, harmonised standards wholly applicable to this equipment at this time. The equipment complies with the essential safety requirements (EHSR's) described in Annex I of the directive 2006/42/EC.
- The manufacturer's quality assurance system is to ISO 9001 (approval cert no. LRQ 0912064).
- A technical file relating to this machinery and proving conformity to the above mentioned directive is maintained by Hydratight.
- Technical specifications and design standards used are those developed by Hydratight and are identified in the technical file described above.

## ANNEX 2. ENVIRONMENTAL STATEMENT



Hydratight Limited operates an environmental management system and is certified by LRQA to BS EN ISO 14001:2004 under certificate number LRQ 4000352.

A principle objective of such a system is to minimise, where technically possible and economically viable, the impacts of a company's activities on the environment. This is particularly relevant to the recycling and safe disposal of packaging, oils and metallic component parts at the end of their useful life. As part of Hydratight's commitment to good environmental practice we respectfully urge our customers to consider such matters in their use of Hydratight bolt tensioning equipment.

Hydraulic bolt tensioning equipment is typically 98% alloy steel by weight and can be readily recycled. Hydraulic fluid remnants within the tensioners should be carefully drained and disposed of in line with local environmental directives. The remaining non-metallic seals are not readily recycled. Further advice on recycling and safe disposal methods can be obtained from local environmental agencies.