

Instruction Sheet
Bar Cutter
Model EBE22

INDEX

1.0 SAFETY 1

2.0 PRODUCT DATA 6

3.0 CONFORMANCE TO NATIONAL AND INTERNATIONAL STANDARDS 7

4.0 DESCRIPTION 7

5.0 RECEIVING INSTRUCTIONS 7

6.0 SET-UP 8

7.0 POWER REQUIREMENTS 8

8.0 MAJOR FEATURES AND COMPONENTS ... 8

9.0 CUTTER OPERATION 10

10.0 MAINTENANCE 12

11.0 CLEANING THE PISTON AREA 19

12.0 STORAGE 20

13.0 TROUBLESHOOTING 20

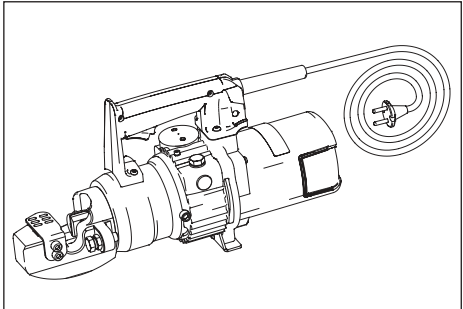

property damage messages and designate a degree or level of hazard seriousness. The Signal Words used in this manual are DANGER, WARNING, CAUTION and NOTICE.

1.0 SAFETY

1.1 Introduction

Read all instructions carefully. Follow all recommended safety precautions to avoid personal injury as well as damage to the product and/or damage to other property. Enerpac cannot be responsible for any damage or injury from unsafe use, lack of maintenance or incorrect operation. Do not remove warning labels, tags, or decals. In the event any questions or concerns arise, contact Enerpac or a local Enerpac distributor for clarification.

If you have never been trained on high-pressure hydraulic tool safety, consult your distributor or service center for information about an Enerpac hydraulic safety course.

This manual follows a system of safety alert symbols, signal words and safety messages to warn the user of specific hazards. Failure to comply with these warnings could result in death or serious personal injury, as well as damage to the equipment or other property.

 The Safety Alert Symbol appears throughout this manual. It is used to alert you to potential physical injury hazards. Pay close attention to Safety Alert Symbols and obey all safety messages that follow this symbol to avoid the possibility of death or serious personal injury.

Safety Alert Symbols are used in conjunction with certain Signal Words that call attention to safety messages or

 **DANGER** Indicates a hazardous situation that, if not avoided, will result in death or serious personal injury

 **WARNING** Indicates a hazardous situation that, if not avoided, could result in death or serious personal injury.

 **CAUTION** Indicates a hazardous situation that, if not avoided, could result in minor or moderate personal injury.

 **NOTICE** Indicates information considered important, but not hazard related (e.g. messages relating to property damage). Please note that the Safety Alert symbol will not be used with this signal word.

1.2 Hydraulic Cutter Safety Precautions

 **WARNING** Failure to observe and comply with the following precautions and instructions may result in death or serious personal injury. Property damage could also occur.

- Read and completely understand the safety precautions and instructions in this manual. Always follow all safety precautions and instructions, including those that are contained within the procedures of this manual.
- Read this manual before operating the cutter, or before performing any adjustments, inspections, maintenance or repairs.
- Follow all instructions and heed all precautions stated in this manual.

- Keep this manual for future reference in a place that is accessible to all persons operating or servicing the cutter.
- Always perform a visual inspection of the cutter before placing it into operation. If any problems are found, do not use the tool. Make repairs before using the cutter.
- Do not use the cutter if it is leaking oil. Do not use the cutter if damaged, altered or in need of repair.
- Do not remove or disable cutter safety devices. Before using the cutter, make sure that all the safety devices (guards, etc.) are in place and in good condition.
- Do not remove the guards installed on the cutter or on any accessories. Replace any guards immediately if they develop faults or become damaged.
- Do not alter the calibration of the safety devices, such as maximum pressure valves (if equipped).
- Allow only authorized, trained, and experienced personnel to operate the cutter and supervise its use.
- Ensure that all users are trained and qualified to operate the cutter. Operators must be aware of all applicable occupational safety laws and must operate the cutter in accordance with all such laws.
- Keep the work area clean and well illuminated.
- When operating the cutter, do not wear loose clothing or jewelry that could get caught up in the cutter during operation. Tie up long hair.
- Always wear and use appropriate personal protective equipment (PPE) such as non-skid safety shoes, hard-hat, hearing protection and face and eye protection. Use of these and other PPE items (used as appropriate for conditions) will reduce the chance of personal injuries. The use of these items may also be required by local regulations or laws.
- Consult your employer concerning specific safety requirements and the safety equipment required for use in your country or region.
- Be certain that the cutter safety guard is installed before starting the cutter. Never operate the cutter with the cutter safety guard removed, or if the safety guard is loose or damaged.
- Before reaching inside the cutting area for any reason, always stop the cutter and disconnect it from the AC power supply.
- Keep others clear of the work area while the tool is in use. Be sure that all personnel not operating the cutter remain at a safe distance when the cutter is in operation.
- Stop the cutter if people and/or animals enter the work area.
- Ensure that the operator is alert, observant of the task being performed and that the work is being done with care.
- Do not allow use of the cutter by persons that are tired, or under the influence of drugs, alcohol or medication.
- Do not allow children to operate the cutter or to assist with its use. Keep children out of the work area.
- Place the tool horizontally on a substantial work surface. The work surface must have a rated weight capacity that exceeds the weight of the cutter and of the material being cut.
- Fragments and splinters may be ejected from the cutter during normal use. The end of the material being cut may become a projectile as it separates during cutting. Stay clear of the cutting head and surrounding area during operation. Always wear face and eye protection.
- As needed, remove any foreign objects from the cutting head that could damage the cutter and/or injure the operator. Before removing any foreign objects, always stop the cutter and disconnect it from AC power supply.
- Avoid touching the cutter's metal surfaces during operation and after the cutter has been in use. Be aware of the risk of burns if the cutter becomes hot.
- Do not use the cutter for activities other than those it was approved and designed to perform. Refer to Section 9.1 of this manual for additional information regarding foreseen use.
- Use the cutter's built-in handle when lifting or moving the cutter. Use appropriately rated lifting equipment if it is necessary to lift or suspend the tool by mechanical means.
- Do not exceed equipment ratings. Never attempt to cut an item that is above the maximum allowable diameter, tensile strength or hardness for your cutter model. For additional information, refer to Section 2.1 of this manual. Overloading may cause equipment failure and possible personal injury.
- Do not use the cutter in explosive atmospheres (for example, in the presence of flammable liquids, gasses or powders).
- Do not use the cutter on live electric lines, on pressure vessels or ducts, or on vessels containing corrosive and/or toxic substances.
- If the cutter malfunctions, stop use immediately. Check for misaligned or jammed moving parts, broken components and any other condition that could make the tool operate incorrectly. Place the cutter back into operation only after the fault has been identified and the identified repairs and/or adjustments have been performed.
- Ensure that any repairs are performed only by trained, qualified and authorized staff using original equipment replacement parts. For repair service, contact the Enerpac authorized service center in your area.
- Use only original equipment Enerpac parts. Enerpac parts are designed to fit properly and to withstand high loads. Non-Enerpac parts may break or cause the product to malfunction.

- Keep cutting tools clean and replace blades when they become dull. Suitably maintained cutting tools with sharp edges are less likely to jam and are easier to control.

⚠ CAUTION Failure to observe and comply with the following precautions and instructions could result in minor or moderate personal injury. Property damage could also occur.

- To help ensure proper operation and best performance, use only Enerpac HF hydraulic oil. Use of any other oil may result in unsafe operation and/or damage to tool. The Enerpac product warranty may also be invalidated.
- Keep hydraulic equipment away from flames and heat. Excessive heat will soften packings and seals, resulting in fluid leaks. Heat also weakens hose materials and packings.
- Protect all hydraulic equipment from weld spatter.

1.3 Safety Precautions - AC Powered Electric Tools

⚠ WARNING Failure to observe and comply with the following precautions and instructions could result in death or serious personal injury. Property damage could also occur.

- Always be certain that tool is stopped and disconnected from AC power supply before performing any tool cleaning, maintenance or repair procedures.
- Be certain that the tool is disconnected from the AC power supply before reaching inside the cutting head to clear jams, or for any other reason.
- Do not leave the tool unattended in the workplace when connected to AC power supply. Take all reasonable precautions to avoid unauthorized use.
- Take precautions so that the tool is not switched on accidentally. Be certain not to press the trigger when picking up the tool or when positioning it.
- If it is not possible to unplug the tool power cord from the AC power outlet, the power must be turned off and locked out at the AC power supply.
- Always disconnect the tool from AC power before transporting it. If electric tools are transported while the operator's finger is on the trigger and AC power is connected, accidents can occur.
- Do not use the tool if it cannot be switched on and off using the trigger. Any tool that cannot be controlled with the trigger is dangerous and must be repaired.
- Remove all wrenches and adjustment tools (if present) before switching on the tool. A wrench or adjustment tool attached to a rotating element of an electric tool can cause personal injury.
- Make sure the cooling vents are unobstructed and that the cooling surfaces are clean in order to avoid dangerous overheating.

- Do not expose the tool to heat sources in excess of 158°F [70°C] as this could cause irreversible damage to cable insulation and other electrical components, possibly leading to a fire. If tool becomes overheated, allow tool to cool or remove heat source.
- The tool is designed for noncontinuous use. Allow sufficiently long pauses to allow the oil to cool. Consult Enerpac if prolonged and/or uninterrupted use is required.
- Do not service or clean the tool, or replace blades or guards, while the tool is operating and/or if tool is connected to AC power supply.
- Keep electric tools out of the reach of children. Do not allow inexperienced users or users who have not read the instructions to operate them. Electric tools are dangerous in the hands of non-expert users.
- In accordance with the standards indicated and followed by the manufacturer, the equipment components that also perform a safety function (insulators, guards, etc.) must not be repaired, but must instead be replaced with original spare parts.

1.4 Additional AC Electric Tool Safety Instructions

⚠ WARNING Failure to observe and comply with the following precautions and instructions could result in death or serious personal injury.

1.4.1 Use and Care

- Store the tool indoors. Keep in a secured area to prevent use by unauthorized personnel.
- Do not clean the tool with a water spray or the like.
- Do not operate the tool with a damaged cord or plug, or after the tool malfunctions or is dropped or damaged in any manner.
- Return the tool to the nearest Enerpac authorized service center for examination, repair, or electrical or mechanical adjustment.

1.4.2 Disconnecting Power

- Be sure that tool motor is off before removing plug from electrical outlet.
- Do not unplug the tool by pulling on the cord. To unplug, grasp the plug, not the cord.
- Remove plug from electrical outlet when the tool is not in use and before servicing or cleaning the tool.

⚠ DANGER High voltage is present inside the tool even when tool motor is off. Before servicing the tool, be sure that the tool power cord is disconnected from the electrical outlet or other electrical power source.

1.4.3 Grounding Instructions

⚠ DANGER Risk of electric shock! Connect the tool only to a properly grounded outlet.

The tool is equipped with a polarized power plug.

The plug must be plugged into a polarized electrical outlet that is properly installed and wired in accordance with all local codes and ordinances.

- If the cord and/or plug are damaged, do not connect the tool to a live electrical outlet. Repair or replace the damaged items and be sure the polarized plug is correctly wired before reconnecting the tool to the outlet. Consult a qualified electrician if wiring procedures are not completely understood or if there is any doubt as to whether the tool is properly wired.
- Do not modify the plug provided with the tool. If the plug will not fit in the outlet, have a proper outlet installed by a qualified electrician. A qualified electrician should be consulted if there is any doubt as to whether an outlet box is properly wired.
- All 230V tool models: The tool is for use on a single-phase circuit, which has a nominal rating of more than 120 volts and is factory equipped with a specific electric cord and plug.
- If the tool must be used with a different type of electric socket, the plug should be changed by a qualified electrician. After the plug is changed, the tool should comply with all local codes and ordinances.

1.4.4 Use of Extension Cords

It is important to use the proper size extension cord with the tool power cord when use of an extension cord is necessary.

A qualified electrician should be consulted to help specify and select the proper size extension cord.

⚠ DANGER Risk of electric shock! Connect the tool only to a properly wired outlet.

If an extension cord is used:

- 1) The marked electrical rating of the extension cord should be at least as great as the electrical rating of the tool.
- 2) The extension cord should have a polarized plug at one end and a polarized receptacle at the other. It should be wired for single phase power.
- 3) A long extension cord should be arranged so that it will not drape over any working area where it can be tripped over, snagged, or pulled on unintentionally.

If the tool is to be operated outdoors and an extension cord is needed, use only an outdoor-use extension cord. An outdoor-use extension cord will be clearly marked with the suffix letter "W" and the statement "Suitable for Use with Outdoor Appliances."

1.4.5 Additional Precautions

⚠ WARNING Do not use electric powered tools in an explosive atmosphere. Sparks and electrical arcing could ignite combustible vapors or airborne dust.

NOTICE To prevent damage to the tool electric motor, check power specifications on tool data plate. Use of incorrect outlet will damage the motor.

1.5 Safety Symbols (located on cutter)

⚠ WARNING Failure to observe and comply with the safety symbols affixed to the cutter housing could result in death or serious personal injury.

⚠ WARNING Make sure the safety symbols (decals, labels, etc.) are securely affixed to the tool and that they are legible. If not, obtain replacements from Enerpac. Refer to tool repair parts sheet for locations and part numbers. Failure to maintain safety symbols on tool could result in death or serious personal injury.

The following safety symbols are affixed to the cutter housing:



Crush hazard: Keep hands, fingers and other body parts away from the cutting head during operation.



Projectile hazard: Objects may be ejected from the cutter during operation. Stay clear of cutting area. Wear eye and face protection.



PPE Alert: Wear personal protective equipment (PPE) when using or servicing equipment.



Instruction Manual Alert: Read the instruction manual before using or servicing equipment.

1.6 Crush Hazard

⚠ DANGER Cutter will start immediately when connected to AC power supply and on-off trigger is depressed.

DO NOT place hands, fingers or other parts of your body inside the cutting head unless cutter is disconnected from AC power supply. Death or serious personal injury will result if cutter is started while persons are working inside the cutting head.

- Never reach into the cutting head while cutter is in operation.
- Before reaching inside the cutting head for any reason, always stop the cutter and disconnect it from AC power supply.

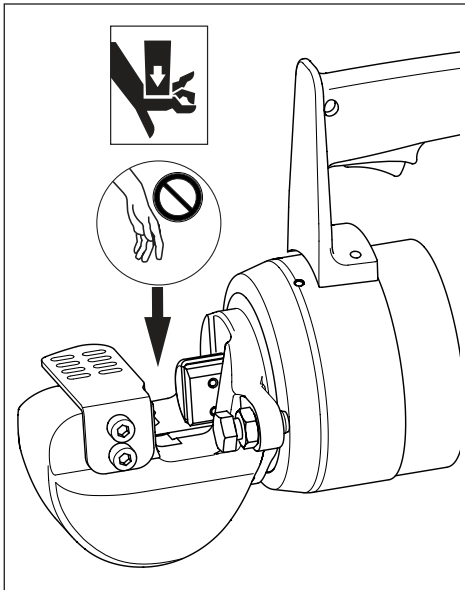

2.0 PRODUCT DATA

2.1 Cutter Maximum Capacities

Material to be Cut	Cutter Model No.	Material Maximum Diameter		Material Maximum Tensile Strength		Material Maximum Hardness
		in	mm	psi	daN/mm ²	Rockwell C
Round, square or flat metal bars	EBE22B	.87	22	94,275	65	43
	EBE22E	.87	22	94,275	65	43

NOTICE Material to be cut must not exceed any of the stated maximum limits shown in this table. Cutter may stall during operation if one or more of the maximum limits is exceeded.

2.2 General Specifications

Cutter Model No.	Max. Cutting Force		Weight		Max. Hydraulic Operating Pressure		Ambient Operating Temp		Hyd. Pump
	Tons	kN	lb	Kg	psi	bar	°F	°C	Type
EBE22B	25.1	223	29	13	8412	580	-40	-40	Internal AC Electric
EBE22E	25.1	223	29	13	8412	580	+122	+50	

2.3 Power and Noise Level Specifications

Cutter Model No.	Volts	Hz	Watts	Amps	Insulation Class	Noise Level (typical)	
						No Load L _{WA} †	No Load Operator L _{PA} ‡
EBE22B	120	60	1300	11.0	II	101	90
EBE22E	230	50	1400	6.8	II	101	90

Notes:

† Per CEI EN 60745-1 and CEI EN 60745-2-8 [dB].

‡ Per CEI EN 60745-1 and EN ISO 5349.

2.4 External Dimensions

Dimension	in	mm
A	18.1	460
B	5.5	140
C	9.8	249

Product specifications are subject to change without notice.

3.0 CONFORMANCE TO NATIONAL AND INTERNATIONAL STANDARDS

CE Enerpac declares that this product has been tested and conforms to applicable standards and is compatible with all CE requirements. A copy of an EU Declaration of Conformity is enclosed with each shipment of this product.

4.0 DESCRIPTION

The Enerpac model EBE22 is a fixed-head hydraulic cutter designed to cut round, square or flat metal bars and other similar items.

The cutter contains two blades, one fixed and one moving. The moving blade is actuated by a hydraulic cylinder.

Hydraulic force is provided by an AC powered electric motor and an internal hydraulic pump. The pump provides oil flow to the hydraulic cylinder, which advances the cylinder piston and moving blade.

A hydraulic reservoir with built-in rubber diaphragm provides a constant supply of oil to the pump, regardless of tool orientation or the amount of piston extension.

A trigger style on-off switch, mounted on the cutter grip, starts and stops the electric motor. The trigger must remain pressed during the cutting process.

An automatic retract feature returns the piston to the fully retracted "home" position when the piston reaches its full stroke and the trigger is released.

A built-in blade safety guard provides protection from splintered material during cutting and helps prevent contact with the blades.

See Figure 1 for a description of cutter major features and components. Refer to Sections 2.1 through 2.4 of this manual for maximum cutting capacities, specifications and dimensions.

5.0 RECEIVING INSTRUCTIONS

Visually inspect all components for shipping damage. Shipping damage is not covered by warranty. If shipping damage is found, notify carrier at once. The carrier is responsible for all repair and replacement costs resulting from damage in shipment.

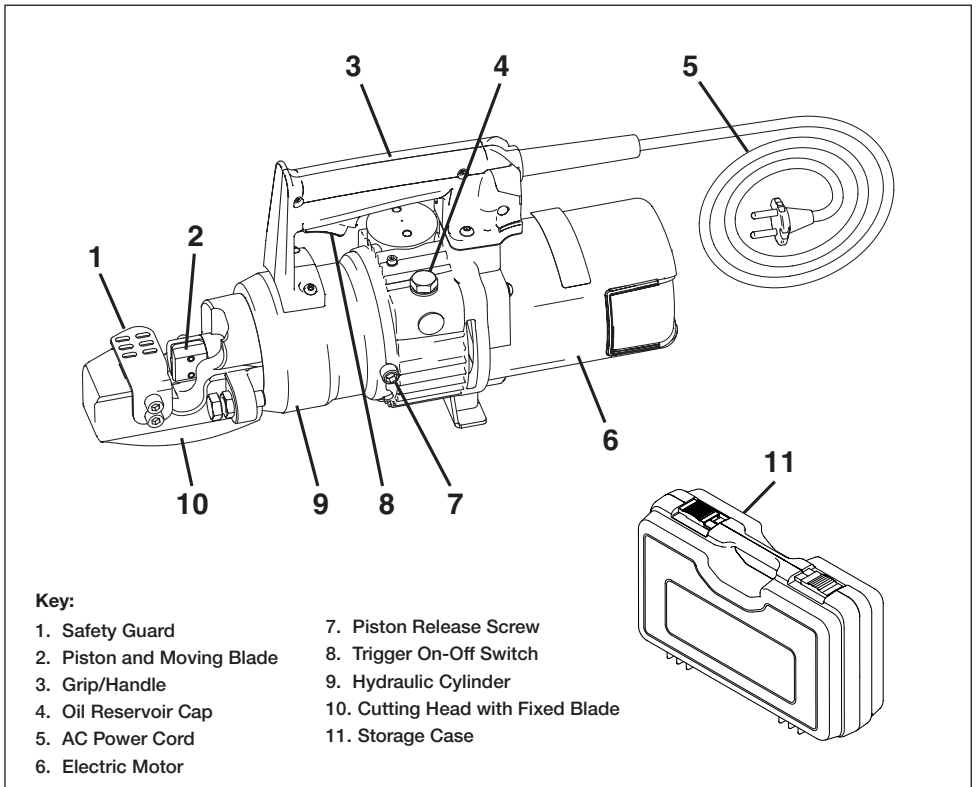

Figure 1, Features and Components

6.0 SET-UP

6.1 Delivery and Handling

The cutter and various related items are housed inside a plastic storage case. The cutter should be stored in this case when not in use.

Place the cutter on a substantial and stable work surface. The work surface must be of sufficient capacity to support the weight of the cutter plus the additional weight of the material to be cut. Refer to Section 2.2 for cutter weight.

6.2 Before Startup

- Be sure that the shipment includes all components and that there is no obvious damage.
- Read the following sections of this manual to become familiar with cutter features and safety devices.
- Verify that the AC power supply is of the correct specifications and capacity to power the cutter. Refer to Section 7.0 of this manual for additional information.

NOTICE Be sure that cutter piston is advanced as far as possible before removing oil reservoir cap in the next step. Oil leakage and improper operation may result if this instruction is not followed.

- Advance the piston as far as possible, disconnect AC power cord and check the cutter hydraulic oil level. Add oil if oil level is low. Refer to Section 10.5.2 for detailed instructions.
- Be sure that the piston release screw is fully tightened. Refer to Section 8.2.
- Before first use, remove air from the cutter hydraulic system. Refer to procedure in Section 9.3.

7.0 POWER REQUIREMENTS

The cutter is available in two versions, each with different electrical power requirements:

Model EBE22B is designed for 120VAC, single-phase, 60 Hz power. This version contains a USA style NEMA 6-15 power plug.

Model EBE22E is designed for 230VAC, single-phase 50 Hz power. This version contains a European style “Schuko” power plug.

Before connecting electric power to tool, be certain that the power supply is the proper voltage and Hz for the cutter version that you are using. Refer to the cutter data plate.

Also refer to Sections 1.3 and 1.4 of this manual for important electrical safety information and precautions.

WARNING Failure to follow the electrical safety precautions contained in Sections 1.3 and 1.4 of this manual could result in electric shock. Death or serious personal injury could occur.

8.0 MAJOR FEATURES AND COMPONENTS

8.1 Trigger On-Off Switch

WARNING To prevent serious personal injury, be certain that hands, fingers and other body parts are away from the cutting area before depressing the cutter trigger.

A trigger mounted in the cutter grip controls cutter operation. Pressing the trigger automatically starts the cutter electric motor. See Figure 2.

- Press and hold the trigger to advance the piston and slide the moving blade forward.
- Release the trigger at any time to stop the piston and moving blade. Be advised that there may be a brief delay until the piston comes to a complete stop.
- After the piston is fully advanced and the trigger is released, the piston will automatically reverse direction and move to the fully retracted “home” position.
- Automatic return can occur only after the piston has been fully advanced. If the trigger is released before the piston is fully advanced, the piston will stop and remain stopped.

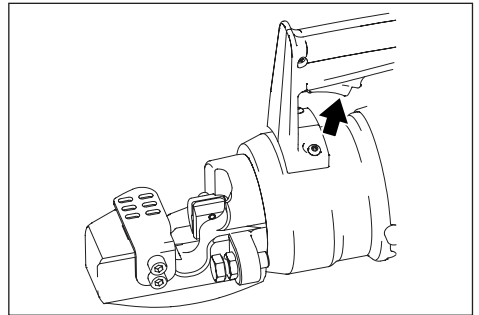

Figure 2, Trigger On-Off Switch

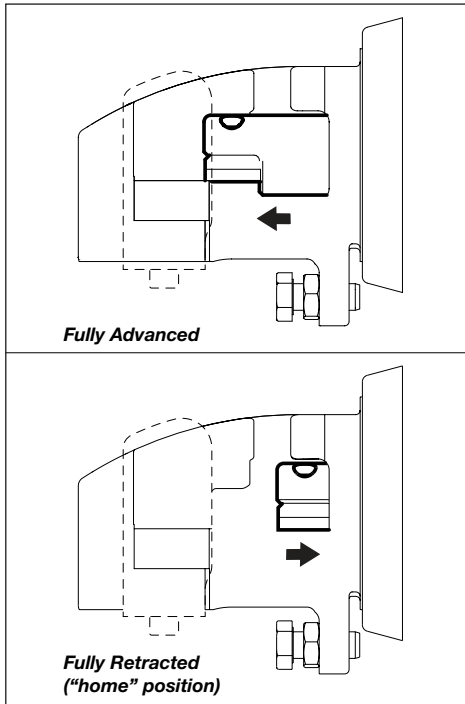

Figure 3, Piston Positions (viewed from top)

8.2 Piston Release Screw

Before using the cutter, check that the piston release screw is turned fully clockwise. Use an 8 mm Allen wrench. See Figure 4.

In the event that the blade becomes stuck during cutting, loosen the piston release screw one full turn counter-clockwise to manually release the piston. When the screw is loosened, the piston will retract immediately, assuming that no dirt or debris is preventing its return.

CAUTION To prevent possible oil leakage, do not loosen the piston release screw more than one full turn counter-clockwise.

NOTICE Refer to the procedures in Section 11.0 of this manual if the blade is not returning due to accumulated dirt or debris.

Tighten the piston release screw to resume normal operation. Note that the piston will not advance when the screw is loosened.

Be advised that the piston release screw is intended for occasional use only. If the piston repeatedly fails to retract automatically after it is fully extended, have the tool inspected by an Enerpac Authorized Service Center.

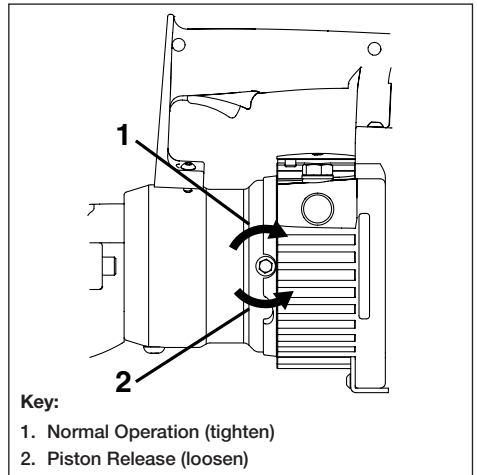

Figure 4, Piston Release Screw

8.3 Blade Safety Guard

The cutter is equipped with a safety guard to prevent contact with the upper part of the fixed blade. See Figure 5.

The blade safety guard is manufactured of stainless steel and is secured to the cutting head with two screws.

WARNING Failure to observe and comply with the following precautions and instructions could result in death or serious personal injury.

- Never operate the cutter with safety guard removed.
- Be certain that safety guard is in good condition and tightly secured. Replace guard if worn, damaged or missing. Tighten or replace screws if loose or missing.
- Always reinstall safety guard after performing any adjustments, maintenance or repairs.

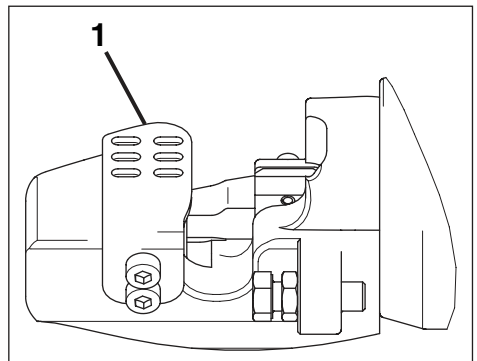

Figure 5, Blade Safety Guard (1)

9.0 CUTTER OPERATION

9.1 Foreseen Use and Residual Risks

⚠ WARNING Failure to observe and comply with the instructions and precautions contained in the following paragraphs could result in death or serious personal injury.

1. The cutter must be used only to cut round, square or flat metal bars and other similar items. Material diameter, tensile strength and hardness must not exceed the maximum allowable values shown in Section 2.1 of this manual.

2. The cutter may be used only if powered by an electrical system compliant with legislation and current law (suitably connected to a grounded electrical system and protected from current surges and short circuits).

3. Operators must observe the instructions in this manual in order to minimize the risk of accidents. In particular, operators must pay attention when working in conditions that could cause:

- Possible burns from overheated metal parts.
- Injury due to incorrect positioning or inadequate lifting or moving.
- Injury caused by splinters discharged from the workpiece.

⚠ WARNING People remaining in the vicinity of the cutter while it is working are subject to the risk of flying debris (dangerous objects, etc.). Serious personal injury could result.

4. Mechanical vibrations transmitted to the hands and arms can pose a risk to the health and safety of workers. The user and/or employer is responsible for assessing the risk generated by mechanical vibrations from the cutter, and minimizing the possibility of injury.

5. Incorrect use:

- The cutter must not be used for purposes other than indicated in this manual.
- The cutter must not be used in areas subject to the risk of explosion.

9.2 Operating Precautions

⚠ WARNING Failure to observe the following precautions and instructions could result in death or serious personal injury.

• Keep fingers, hands and other body parts clear of the cutting head. Do not reach into the cutting area during cutter operation.

• Do not attempt to reposition the item being cut while the cutter is in operation. If repositioning is required, stop the cutter and loosen the piston release screw to retract the piston. Then, tighten the piston release screw and repeat the cutting process.

• Dangerous projectiles could occur at any time during cutting. Always wear face and eye protection. Keep persons away from cutting area.

• Cutter surfaces can become very hot. To prevent burns, avoid contact with cutter components and wear appropriate personal protective equipment.

• Refer to additional safety precautions in Section 1.0 of this manual before using the cutter or performing any maintenance or repair activities.

9.3 Trapped Air Removal

Before placing a new cutter into operation, cycle the piston several times without load to remove any trapped air in the hydraulic circuit.

Air is completely purged when the piston advances and retracts smoothly in both directions, from fully advanced to fully retracted.

This procedure should be performed after the oil in the cutter is changed, and after any maintenance or repair activity in which the oil is drained and replaced.

9.4 Locating and Positioning the Cutter

• Before inserting material to be cut inside the cutting head, be certain that the cutter is placed on a solid and stable work surface of sufficient weight rating capacity. Refer to the cutter data plate for cutter weight.

• Position the cutter as needed using the handle/grip mounted at the top of the cutter. The handle/grip can also be used for transporting the cutter short distances.

⚠ WARNING Because the cutter components are very heavy, there is a risk of cuts, crushing or broken bones. To avoid accidents, use care when working with the cutter. Serious personal injury may result if the cutter is not properly supported and handled in an appropriate way.

9.5 Positioning Material Inside the Cutting Head

Be sure that the piston and moving blade are located in the fully retracted “home” position before placing any material inside the cutting head. See Figure 6.

Position the material to be cut between the cutter blades, so that it is perpendicular to the piston axis, as shown in Figure 6. This will provide the best quality cut while placing the least amount of load on the cutter.

Adjust the support bolt as needed. The head of the support bolt should just touch the surface of the material to be cut, when the item is positioned against the fixed blade of the cutter.

After adjusting the support bolt, be sure that the support bolt retaining nut is snug tight against the support bolt mounting ear. This will help prevent support bolt movement during cutting.

NOTICE Be certain that the hardness, tensile strength and diameter of the material to be cut do not exceed any of the stated maximum limits. Refer to Section 2.1 of this manual for additional information. Failure to observe this instruction may result in poor cutting performance and/or damage to the cutter.

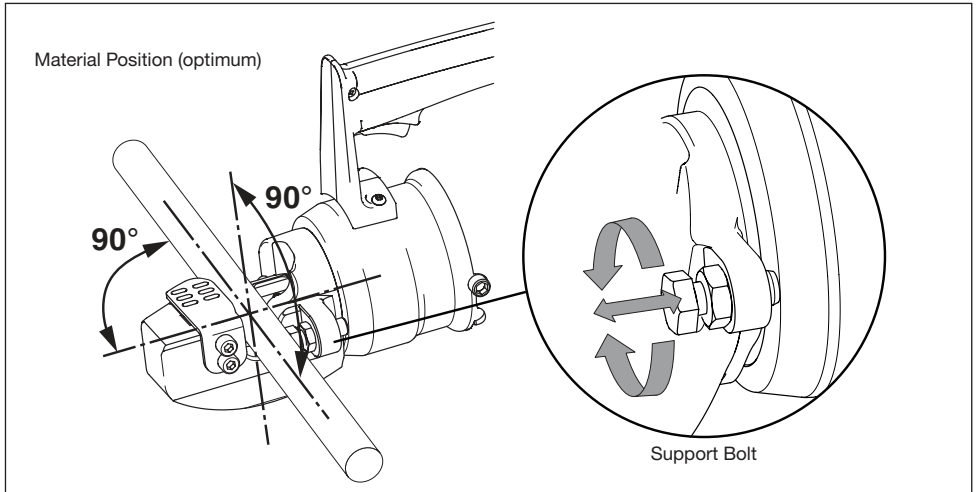

Figure 6, Positioning Material Inside Cutting Head

9.6 Cutting Procedure (typical)

1. Connect the cutter to the electrical outlet.
2. Be sure that the piston is in the “home” (fully retracted) position. See Figure 3.
3. Be sure that the piston release screw is turned fully clockwise. See Figure 4.
4. Place the material to be cut between the fixed and moving blades. Refer to instructions in Section 9.5 for additional information.

NOTICE Position the item to be cut so that it is as perpendicular as possible to the blades, as described in Section 9.5. Positioning the material at an angle will side-load the piston. Jamming and/or damage to the cutter may result.

5. Be certain that hands, fingers or other body parts are not inside the cutting head.
6. Press and hold the trigger to start the motor and begin cutting.

7. After cutting is completed, wait until the piston reaches the end of its stroke and then release the trigger. Verify that the moving blade reverses direction and moves fully into the “home” (fully retracted) position.

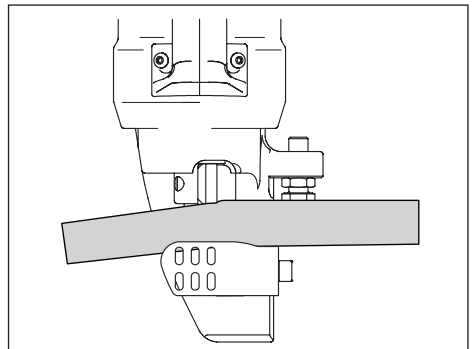

Figure 7, Material Being Cut (typical - top view)

10.0 MAINTENANCE

10.1 Preparation for Maintenance

All cutter maintenance procedures must be performed under the following conditions:

- Material must be removed from the cutting head.
- The cutter must be disconnected from the AC power supply.
- The cutter must be given time to cool to prevent burns.
- Procedures must be performed in a suitable work environment in accordance with all current safety regulations and/or laws in your country or region.
- The cutter must be cleaned thoroughly before maintenance procedures are performed.
- Suitable personal protective equipment (PPE) must be used and/or worn while performing any work.

⚠ WARNING The cutter must sometimes be operated in order to complete a maintenance or repair procedure being performed, or to prepare it for a procedure that is about to be performed.

However, to prevent startup while persons are working on the cutter, always disconnect the cutter from the AC power supply before beginning any procedure steps that require use of tools and/or physical contact with the cutter. Failure to observe this precaution may result in death or serious personal injury.

⚠ WARNING Ensure that cutter safety guard has been correctly reinstalled before placing the cutter back into service after maintenance procedures are completed. Failure to reinstall this guard could result in serious personal injury.

Table 1 - Periodic Maintenance Chart

Time Interval	Maintenance Operation	Method	To be performed by:
Every 8 hours of operation:	Check the cutter for loose, damaged or worn parts. Check for oil leaks. Tighten, replace or repair as required.	Visual	Operator
	Clean the cutter exterior.	Refer to instructions in Section 10.3.	Operator
	Clean the cutter piston.	Refer to instructions in Section 11.1 and 11.2.	Operator
	Check the tightening torque of screws and bolts. Replace any missing screws or bolts.	Use torque wrench. Refer to repair parts sheet for complete torque specifications.	Operator
Every 1600 hours of operation:	Change the hydraulic oil.	Refer to instructions in sections 10.5.1 - 10.5.3.	Service Center
As required:	Replace fixed blade.	Refer to instructions in Section 10.6.2.	Operator
	Replace moving blade.	Refer to instructions in Section 10.6.3.	Operator

10.2 Periodic Maintenance Chart

Refer to the Periodic Maintenance Chart (Table 1) for a list of various routine checks and procedures.

10.3 Cleaning

- Clean the cutter using a dry cloth or compressed air. For plastic surfaces, use a cloth slightly dampened with water.

⚠ CAUTION To prevent possible injury, always wear safety glasses or face mask when using compressed air.

- Be sure there are no traces of oil, grease or corrosive substances on the tool, especially on the grips.
- Use a damp cloth and soapy water to clean plastic components.
- Do not use gasoline or thinner to clean the tool.

10.4 Fasteners

Periodically check all screws, nuts and other fasteners for proper tightness. Tighten any loose fasteners. Replace any worn or damaged fasteners. This should be performed periodically or every day in the event of frequent or prolonged cutter operation.

NOTICE Failure to check and tighten fasteners as required may result in serious damage to the cutter.

10.5 Cutter Hydraulic System

The cutter contains a small hydraulic pump and an oil reservoir with a rubber diaphragm. The oil level must be periodically checked and additional oil must be added if the oil level is low. In addition, the oil must be completely changed at the specified interval. Refer to the Periodic Maintenance Chart (Table 1).

10.5.1 Hydraulic System Maintenance Precautions

⚠ WARNING

Always disconnect cutter from AC power supply before performing hydraulic system maintenance. Failure to observe this precaution could result in accidental startup while maintenance procedures are being performed. Serious personal injury and damage to cutter may result.

Wait for cutter to cool before performing hydraulic system maintenance. Hot oil can cause burns.

Be sure that oil reservoir cap is securely tightened after checking oil level or changing the oil. Leaking oil can cause short circuits, fire and explosions.

Additional Precautions:

- Do not check oil level or change the oil in dusty areas.
- Be sure that all tools (wrench, screwdriver, etc.) used to perform maintenance procedures are clean.
- When adding oil and performing oil changes, take every precaution to prevent impurities from contaminating the oil or entering the cutter. Impurities can cause permanent damage to the hydraulic components.
- The hydraulic reservoir contains a rubber diaphragm that slightly pressurizes the oil. Some oil spillage may occur when checking the oil level or when changing the oil. Wear and/or use appropriate personal protective equipment (PPE) to prevent exposure to hydraulic oil.
- Use only new Enerpac HF hydraulic oil poured from a clean container. Use of other oil brands and/or used oil may damage the cutter and may void the Enerpac product warranty.

10.5.2 Checking Oil Level and Adding Oil

NOTICE The reservoir contains a flexible rubber diaphragm that slightly pressurizes the oil. To help prevent excessive oil leakage when the reservoir cap is removed, be certain that the piston is advanced until there is a gap of about 1/8 inch [3-4 mm] between the fixed and moving blades (as described in step 1) before loosening the cap.

The gap between the blades should not be less than 1/8 inch [3-4 mm]. A smaller gap may result in the piston retracting unexpectedly while the oil level is being checked.

Refer to Figures 8A through 8D during the following steps:

1. Operate the cutter and advance the piston until there is a 1/8-inch [3-4 mm] gap between the fixed and moving blades (until just before the piston automatically returns).
2. Disconnect the cutter from the AC power supply to prevent accidental motor start-up during the following steps.

3. Place the cutter in the horizontal position, on a stable and level work surface, with the oil reservoir cap facing upwards. Place a pan or suitable container under the cutter to catch any spilled oil.

4. To prevent contamination, remove any built-up dust and dirt from the oil reservoir cap and surrounding area.

NOTICE A small amount of hydraulic oil may leak from the drain/fill hole when cap is loosened in the next step. Be prepared to catch this oil in a pan or with a clean rag. Dispose of spilled oil in accordance with all applicable laws and regulations.

5. Slowly loosen the oil reservoir cap while watching for oil flow:

- If oil starts flowing from the oil drain/fill hole as the cap is loosened, the reservoir is full. Tighten the cap immediately. To avoid excessive oil spillage, do not continue loosening the cap if oil flow occurs. Skip steps 6 through 8 and go on to step 9.
- If no oil flow occurs when the cap is loosened, fully loosen and remove the cap. Then, check oil level and add oil (if needed) as described in steps 6 through 8.

6. Check the oil level in the drain/fill hole. Oil level will be up to the top of the hole when reservoir is full.

7. If oil level is low, loosen the vent screw to provide venting. Then, slowly add new Enerpac HF oil through the oil drain/fill hole, until the oil level is up to the top of the hole.

8. Remove any residue or metal particles from the oil reservoir cap (it is magnetic).

9. Install and securely tighten the oil reservoir cap.

10. Tighten the vent screw (if loosened).

11. Using a clean rag, wipe the cutter housing, grip and motor so that these surfaces are free of oil residue.

12. Connect cutter to AC power supply. Cycle the piston several times to test for proper operation before placing the cutter back into service.

10.5.3 Changing the Oil

NOTICE The oil change procedure is very detailed and will take a considerable amount of time. It should only be performed by a trained technician at an Enerpac authorized service center. Failure to properly perform the procedure may result in incomplete filling of the cutter oil reservoir, which could lead to cavitation, air entrainment, reduced performance, and pump damage.

Change the oil in the cutter reservoir as described in the following steps. Refer to Figures 8A through 8E:

1. Fill a clean oil dispenser with new Enerpac HF oil. Put the dispenser aside for later use.

2. Procure a thick, soft metal bar (about 1/4 inch [6.4 mm] minimum thickness). Put the bar aside for later use.

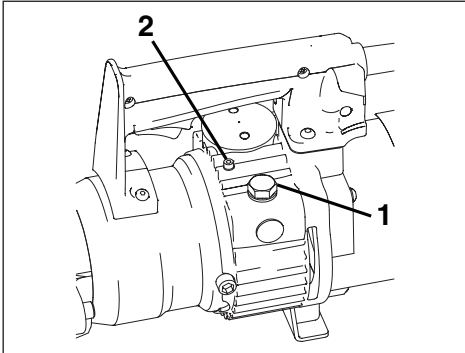

Figure 8A, Oil Reservoir Cap (1) and Vent Screw (2)

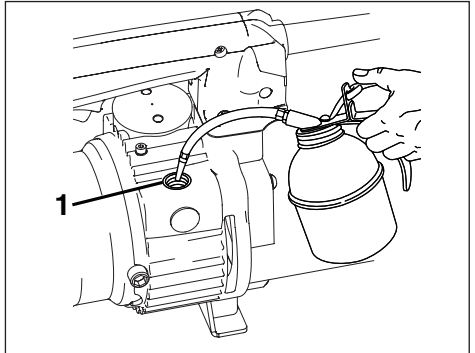

Figure 8D, Adding Oil to Reservoir Fill Hole (1)

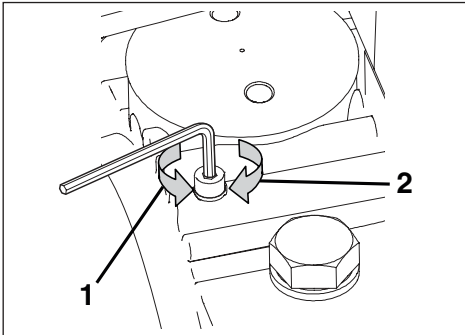

Figure 8B, Vent Screw - Loosen (1) and Tighten (2)

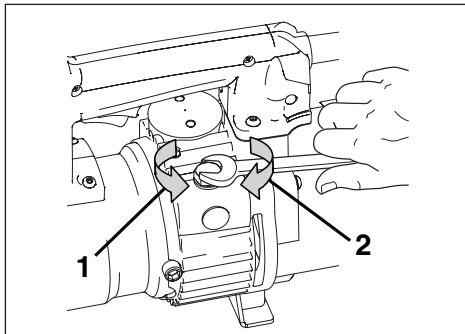

Figure 8C, Oil Reservoir Cap - Loosen (1) and Tighten (2)

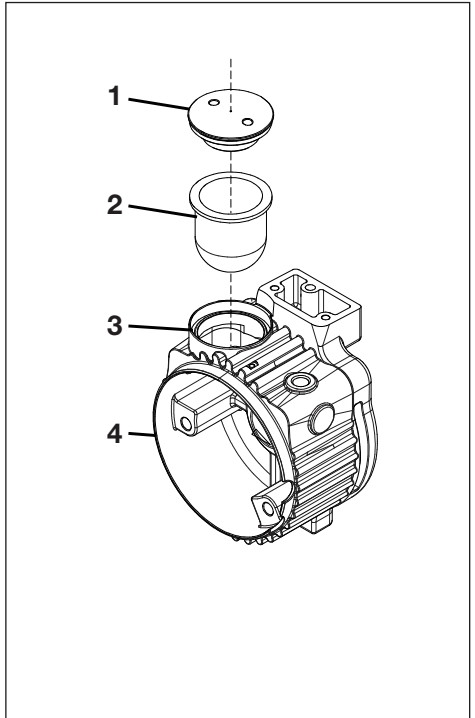

Figure 8E, Diaphragm cover (1), Diaphragm (2), Diaphragm Opening (3) and Oil Reservoir (4)

Figure 8, Hydraulic System Maintenance

NOTICE The bar selected should be easy to cut, but not brittle. The bar material must be soft enough so that the bar will not break into two pieces before it is fully cut. Later in this procedure, the bar will be partially cut so that it becomes lodged in between the jaws of the cutter without being cut through completely, as the piston is extended to slightly less than maximum travel.

3. Disconnect the cutter from the AC power supply to prevent accidental motor start-up during the following steps.

4. Place the cutter in the horizontal position, on a stable and level work surface, with the oil reservoir cap facing upwards. Place a pan or suitable container under the cutter to catch any spilled oil.

5. To prevent contamination, remove any built-up dust and dirt from the oil reservoir cap, diaphragm cover, and surrounding area.

NOTICE A small amount of hydraulic oil leakage may occur when the diaphragm cover is removed in the next step. Be prepared to catch this oil in a pan or with a clean rag. Dispose of spilled oil in accordance with all applicable laws and regulations.

6. Using an adjustable face spanner wrench, loosen and remove the diaphragm cover.

7. Remove the diaphragm element from the diaphragm opening.

8. Loosen and remove the oil reservoir cap.

9. Completely drain all old oil from the cutter, turning it upside down and using a suitable oil extraction system (used oil extraction pump) if necessary, so that no oil remains in the cutter reservoir.

NOTICE Dispose of all used oil in accordance with all applicable regulations and laws.

10. After all oil is evacuated, position the cutter with the oil reservoir cap facing up.

11. Loosen the vent screw to provide venting.

NOTICE Use only new Enerpac HF oil in the following step. Use of other oils may damage the cutter and may invalidate the Enerpac product warranty.

12. Using the oil dispenser prepared in step 1, slowly add new Enerpac HF oil through the oil drain/fill hole and diaphragm opening until oil level is up to the top of the drain/fill hole.

13. Install and securely tighten the oil reservoir cap. Leave the diaphragm element and diaphragm cover removed.

⚠ WARNING To avoid serious personal injury, stay clear of cutting head and blades during the following procedures. Wear rubber gloves to prevent contact with oil. Wear eye and face protection to avoid injury due to splashing oil.

14. Connect the cutter to the AC power supply.

15. Cover the diaphragm opening with a rubber-gloved hand to help prevent oil splashing.

16. Prime the pump by pressing and releasing the trigger in short bursts. During this process, check the oil level in the diaphragm opening and add oil (as needed) to keep the reservoir filled. Failure to keep reservoir full may result in cavitation and pump failure. Pump is primed when piston starts extending.

NOTICE During priming, the oil may become entrained with air and may develop a foamy appearance. This is normal.

17. Continue pressing and releasing the trigger in short bursts as the piston extends. During this process, do not add oil, but verify that the pump has ample oil supply. Continue until piston is extended to approximately half stroke.

NOTICE During the following steps, refer to Figure 4 for piston release screw details.

18. While covering the diaphragm opening with a rubber-gloved hand, retract the piston gently by slowly loosening the piston release screw.

19. Tighten the piston release screw.

20. Place the soft metal bar (refer to step 2) into the cutting head.

21. Press and release the trigger in short bursts until the piston is extended as far as possible, but before it makes a full cut and retracts. The moving blade will become lodged in the bar, preventing the piston from retracting. This procedure is necessary because the cutter mechanism alone may fail to hold the piston in the partially extended position as oil is being added in the following steps.

NOTICE If you cut completely through the bar, try again, cutting as far as you can without making a full cut.

22. Disconnect the cutter from the AC power supply to prevent accidental motor start-up during the following steps.

23. Add oil through the diaphragm opening until the bladder opening is nearly full.

24. Slowly install the diaphragm element in the diaphragm opening. This should result in some oil leakage from the vent screw, as well as from around the diaphragm element.

25. Tighten the vent screw.

26. Install and securely tighten the diaphragm cover.

27. Loosen the piston release screw to retract the piston. If piston is stuck, use the bar to manually push the piston back until it retracts.

28. Remove the soft metal bar from the cutting head. Do not discard the bar. It will be used again later in this procedure.

29. Tighten the piston release screw.

30. Connect the cutter to the AC power supply.

⚠ WARNING To avoid serious personal injury, stay clear of cutting head and blades during the following procedures.

31. Start the cutter and cycle the piston through several advance and return strokes. Ensure that piston is fully retracted when done.
32. Be sure cutter is positioned so that the oil reservoir cap is facing upwards. **Do not operate cutter for several hours (preferably overnight) to allow any remaining air to separate from the oil.**
33. Place the soft metal bar (refer to step 2) into the cutting head.
34. Press and release the trigger in short bursts until the piston is extended as far as possible, but before it makes a full cut and retracts. The moving blade will become lodged in the bar, preventing the piston from retracting. This procedure is necessary because the cutter mechanism alone may fail to hold the piston in the partially extended position as oil level is being checked in step 35.

NOTICE If you cut completely through the bar, try again, cutting as far as you can without making a full cut.

35. Disconnect the cutter from the AC power supply to prevent accidental motor start-up during the following steps.
36. Loosen and remove the oil reservoir cap. Recheck the oil level in the oil drain/fill hole. If oil level has dropped, loosen vent screw and add additional Enerpac HF oil until the oil level is up to the top of the hole.
37. Install and securely tighten the oil reservoir cap.
38. Tighten the vent screw (if loosened).
39. Using a clean rag, wipe the cutter housing, grip and motor so that surfaces are free of oil residue.
40. Connect the cutter to the AC power supply. Cycle the piston several times to test for proper operation before placing the cutter back into service.

10.6 Cutter Blade Replacement

⚠ WARNING

- Always disconnect cutter from AC power supply before beginning blade replacement procedures. Failure to observe this precaution could result in accidental startup during blade replacement. Serious personal injury could result.

- Use extreme caution when removing and installing blades. Blades may be sharp even when worn. To avoid hand injury, wear appropriate personal protective equipment (PPE) and avoid contact with blade cutting edges.

10.6.1 Blade Wear

The use of worn blades decreases the effectiveness of the cutter and can also side load the cylinder, resulting in possible damage to the tool. Motor overheating can also occur.

Replace blades immediately if they are worn and/or damaged or if there has been a noticeable decrease in cutting performance.

NOTICE Blades are not sharpenable and must be replaced when worn. To help ensure optimum cutting performance, replace both the fixed blade and the moving blade at the same time.

10.6.2 Blade Replacement - Fixed Blade

Replace the fixed blade as described in the following steps. Refer to Figure 9, items 1, 2 and 3.

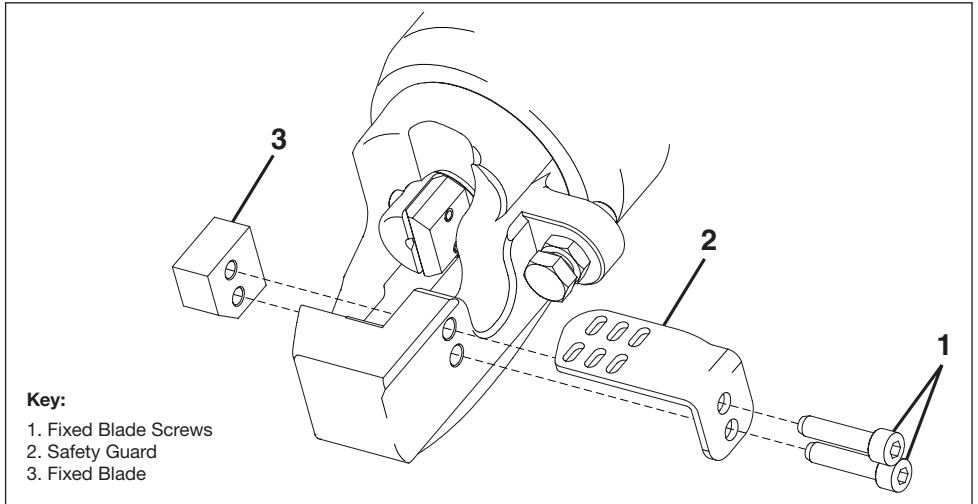

Figure 9, Fixed Blade Replacement

1. Be sure that the cutter piston is fully retracted. If not, start the cutter and cycle the piston until it is fully retracted.
2. Disconnect cutter from AC power supply to prevent accidental motor startup during the following steps.
3. Place the cutter horizontally on a stable work surface with the oil reservoir cap facing upwards.
4. Remove the fixed blade screws.
5. Remove the safety guard.
6. Remove the worn fixed blade and replace it with the new fixed blade.
7. Reinstall the safety guard. Secure the safety guard and the new fixed blade using the two new fixed blade screws included with the new fixed blade. Apply Loctite 243 thread sealant (or equivalent) to threads. Torque to 18 ft-lb [25 Nm].
8. Test cutter for proper operation before placing it back into service.

10.6.3 Blade Replacement - Moving Blade

Replace the moving blade as described in the following steps. Refer to Figure 10, items 1, 2 and 3.

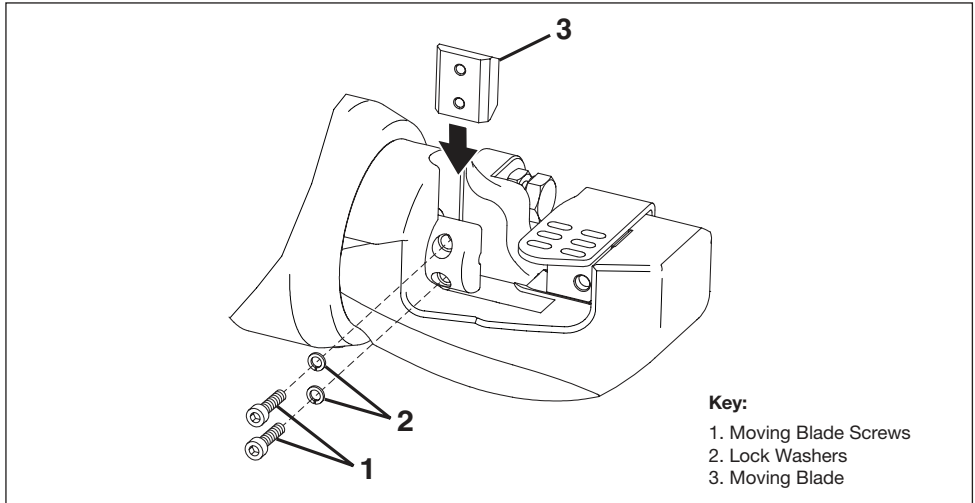

Figure 10, Moving Blade Replacement

1. Be sure that the cutter piston is fully retracted. If not, start the cutter and cycle the piston until it is fully retracted.

NOTICE If the piston will not retract in step 1, loosen the piston release screw and manually retract the piston. See Section 11.2 for procedure.

2. Disconnect cutter from AC power supply to prevent accidental motor startup during the following steps.

3. Place the cutter horizontally on a stable work surface with the oil reservoir cap facing upwards.

4. Remove the moving blade screws and lock washers.

5. Remove the worn moving blade and replace it with the new moving blade.

NOTICE If needed, use a screwdriver or small pry bar to separate the worn moving blade from the mating surface of the piston.

6. Secure the new moving blade with the new moving blade screws and lock washers included with the new moving blade. Torque to 52.9 in-lb [5.98 Nm].

7. If loosened, tighten the piston release screw. For instructions, refer to Section 8.2.

8. Test cutter for proper operation before placing it back into service.

11.0 CLEANING THE PISTON AREA

⚠ WARNING Always disconnect cutter from AC power supply before cleaning the piston head area or before manually retracting the piston. Failure to observe this precaution could result in accidental startup during cleaning procedures. Serious personal injury could result.

11.1 Cleaning and Inspection

- Keep the piston area clean to ensure that the piston fully returns after it advances to maximum stroke.
- Remove any built-up dirt or debris from the cutting head, the piston and moving blade.

11.2 Manually Retracting the Piston

The piston may fail to fully retract if debris is wedged under or beside the piston and moving blade.

If this condition occurs, it may be necessary to manually retract the piston into the cylinder to fully return the piston to the “home” position.

Refer to the following steps. See Figure 11:

1. Disconnect cutter from AC power supply to prevent accidental motor startup during the following steps.
2. Place the cutter horizontally on a stable work surface.
3. Loosen the piston release screw one full turn counter-clockwise to manually release the piston. Refer to Section 8.2 for additional information.

4. Using a rigid piece of steel bar, manually push the piston inside the cutter until it is returned to the home position. See Figure 11, item 3. This should dislodge any dirt or other material that had prevented the piston from returning during normal operation.
5. Tighten the piston release screw to enable the automatic retract function (normal operation). Refer to Section 8.2 for additional information.
6. Connect cutter to AC power supply. Quickly depress and release the trigger repeatedly until the piston is advanced about 3/4 inch [19 mm].
7. Disconnect cutter from AC power supply to prevent accidental motor startup during cleaning procedures in the following step.
8. Clean the exposed portion of the piston. Remove any debris, chips or dirt from this area. See Figure 11, item 1.
9. Connect cutter to AC power supply and test cutter for proper operation. Verify that piston automatically returns to the “home” position after it is fully advanced and the trigger is released.

NOTICE If the piston still does not fully retract after performing the previously described cleaning procedure, the cutter should be inspected and serviced by an Enerpac authorized service center.

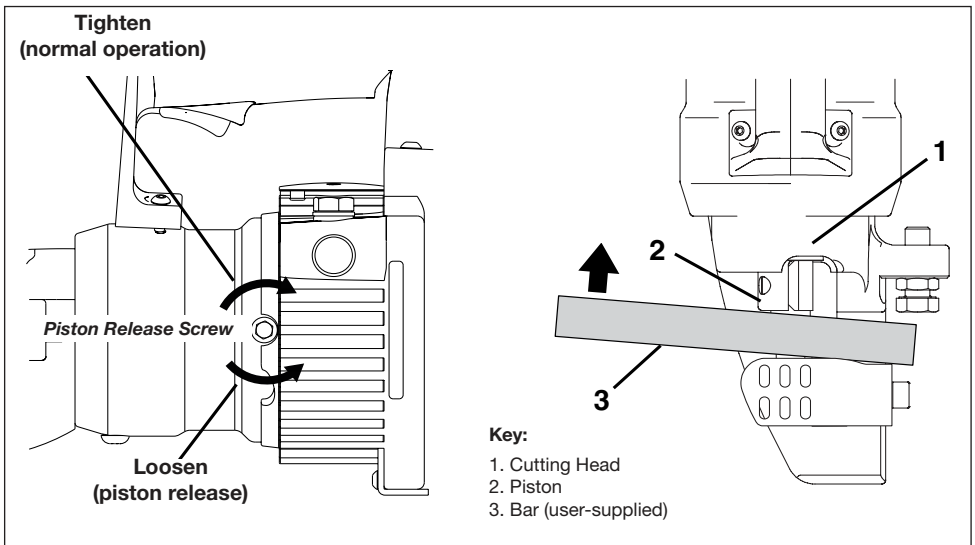

Figure 11, Piston Manual Retract Procedure

12.0 STORAGE

12.1 Storage Guidelines

If the cutter will be stored for an extended period of time:

- Disconnect cutter from AC power supply.
- Thoroughly clean the cutter. Remove any loose dust or dirt. Dry the cutter after completing cleaning procedures.
- Lubricate the cutter metal surfaces using a clean oil-moistened rag to provide added corrosion protection during storage.
- Store the cutter in its plastic storage case, in a clean and dry location, accessible only to authorized personnel.

12.2 Return to Use (after storage)

Before using the cutter after an extended period of storage or inactivity, perform the following steps:

- Check the hydraulic oil level and add oil if low. Refer to instructions in Section 10.5.2.
- Check for oil leaks. Make repairs as required.
- Remove any traces of oil (if present) from the handle/grip and other parts that can be gripped.
- Remove any oil from cutter metal surfaces.
- Check that the electrical power cord and plug are undamaged and in good condition.
- Verify that the cutter housing (including the electric motor) is undamaged.
- Check for any missing, worn or improperly installed parts.
- Check that all screws, nuts, bolts and other fasteners are tight. Replace, repair or tighten components as needed.
- Connect cutter to AC power supply. Cycle the piston several times to test for proper operation before placing the cutter back into service.

13.0 TROUBLESHOOTING

Refer to the Cutter Troubleshooting Charts (Tables 2 and 3) for lists of common cutter symptoms, possible causes and solutions.

For repair service, contact an Enerpac authorized service center. Inspection and repairs should be performed only by an Enerpac authorized service center or other qualified hydraulic tool service facility.

Table 2 - Troubleshooting Chart, Cutter Electrical Components			
Symptom	Possible Cause	Solution	Maint. Level
1. Motor will not start.	No AC electric power.	Check the power supply and circuit breaker or fuses.	Operator
	Worn or broken AC power cord.	Replace old cord with a new cord of the same specifications.	Service Center
	Trigger on-off switch worn or defective.	Replace switch.	Service Center
	Motor rotor windings defective.	Replace rotor and commutator assembly.	Service Center
	Motor stator windings defective.	Replace motor.	Service Center
2. Motor overheats.	Low voltage.	Check AC power supply.	Operator
	Motor ventilation slots obstructed.	Clean any dirt or other obstructions from motor ventilation slots.	Operator
	Worn fixed and/or moving blade.	Replace blades if worn or damaged.	Operator
	Motor brushes worn.	Replace motor brushes if worn (less than 0.2 inch [5 mm] long).	Service Center
	Commutator worn.	Replace rotor and commutator assembly.	Service Center
	Motor fan damaged.	Replace motor fan.	Service Center
	Motor windings dirty.	Clean dirty windings.	Service Center
	Motor bearings worn.	Replace motor bearings.	Service Center
	Motor rotor windings damaged.	Replace rotor and commutator assembly.	Service Center
	Motor stator windings damaged.	Replace motor.	Service Center
3. Motor does not stop when trigger is released.	Trigger on-off switch defective.	Replace switch.	Service Center
	Other electrical problem.	Troubleshoot and repair electrical circuit.	Service Center
4. Electromagnetic disturbances in power line.	Fault in EMI filter.	Replace EMI filter.	Service Center
	Motor brushes worn.	Replace motor brushes if worn (less than 0.2 inch [5 mm] long).	Service Center
	Commutator worn.	Replace rotor and commutator assembly.	Service Center

(Refer to Table 3 for hydraulic component troubleshooting.)

Table 3 - Troubleshooting Chart, Cutter Hydraulic Components

Symptom	Possible Cause	Solution	Maint. Level
1. Piston does not advance.	Return stroke incomplete.	Manually return the piston.	Operator
	Low hydraulic oil level.	Check oil level. Add oil if low.	Operator
	Piston release screw loosened.	Tighten piston release screw.	Operator
	Automatic retract valve remains open due to built-up dirt.	Remove built-up dirt.	Service Center
	Automatic retract valve not working.	Replace automatic retract valve.	Service Center
	Max. pressure valve dirty or requires replacement.	Clean or replace max. pressure valve.	Service Center
2. Piston does not fully advance and/or movement is jerky.	Low hydraulic oil level.	Check oil level. Add oil if low.	Operator
	Air bubbles in the hydraulic circuit.	Operate tool through several full cycles to bleed air. Check oil level and add oil if low.	Operator
	Max. pressure valve open.	Clean or replace max. pressure valve.	Service Center
	Piston gasket worn.	Replace piston gasket.	Service Center
	Pump malfunction.	Repair or replace pump.	Service Center
3. Tool performs with insufficient force..	Max. pressure valve open.	Clean or replace max. pressure valve.	Service Center
	Piston gasket worn.	Replace piston gasket.	Service Center
	Pump malfunction.	Repair or replace pump.	Service Center
4. Return stroke incomplete.	Dirt between piston rod and tool.	Move the piston to the end of stroke position, disconnect AC power and remove any built-up dirt.	Operator
	Piston return spring broken.	Replace the piston return spring.	Service Center
5. Piston does not automatically retract.	Piston has not reached full extension.	Fully extend piston and check if it reverses.	Operator
	Debris is wedged under or beside piston.	Manually retract piston, following the procedure in Section 11.2, then clean piston area.	Operator
	Retract valve not working.	Replace automatic retract valve.	Service Center
	Piston return spring broken.	Replace piston return spring.	Service Center
6. Oil leakage from tank cover.	Reservoir diaphragm faulty.	Replace reservoir diaphragm.	Service Center

(Refer to Table 2 for electrical component troubleshooting.)

ENERPAC 

WWW.ENERPAC.COM