

**Instruction Sheet**  
**Decommissioning Cutters**  
**Models EDCH130, EDCH145 and EDCH170**

INDEX	
1.0 SAFETY .....	1
2.0 PRODUCT DATA .....	5
3.0 CONFORMANCE TO NATIONAL AND INTERNATIONAL STANDARDS .....	8
4.0 DESCRIPTION .....	8
5.0 RECEIVING INSTRUCTIONS .....	8
6.0 SET-UP .....	8
7.0 CUTTER OPERATION .....	10
8.0 MAINTENANCE .....	12
9.0 STORAGE .....	13
10.0 TROUBLESHOOTING .....	14

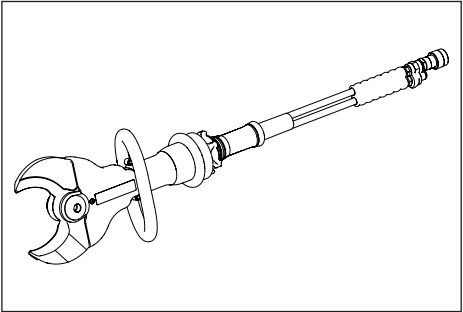

**1.0 SAFETY**

**1.1 Introduction**

Read all instructions carefully. Follow all recommended safety precautions to avoid personal injury as well as damage to the product and/or damage to other property. Enerpac cannot be responsible for any damage or injury from unsafe use, lack of maintenance or incorrect operation. Do not remove warning labels, tags, or decals. In the event any questions or concerns arise, contact Enerpac or a local Enerpac distributor for clarification.

If you have never been trained on high-pressure hydraulic tool safety, consult your distributor or service center for information about an Enerpac hydraulic safety course.

This manual follows a system of safety alert symbols, signal words and safety messages to warn the user of specific hazards. Failure to comply with these warnings could result in death or serious personal injury, as well as damage to the equipment or other property.

 The Safety Alert Symbol appears throughout this manual. It is used to alert you to potential physical injury hazards. Pay close attention to Safety Alert Symbols and obey all safety messages that follow this symbol to avoid the possibility of death or serious personal injury.

Safety Alert Symbols are used in conjunction with certain Signal Words that call attention to safety messages or property damage messages and designate a degree or level of hazard seriousness. The Signal Words used in this manual are DANGER, WARNING, CAUTION and NOTICE.

 **DANGER** Indicates a hazardous situation that, if not avoided, will result in death or serious personal injury

 **WARNING** Indicates a hazardous situation that, if not avoided, could result in death or serious personal injury.

 **CAUTION** Indicates a hazardous situation that, if not avoided, could result in minor or moderate personal injury.

 **NOTICE** Indicates information considered important, but not hazard related (e.g. messages relating to property damage). Please note that the Safety Alert symbol will not be used with this signal word.

**1.2 Hydraulic Cutter Safety Precautions**

 **WARNING** Failure to observe and comply with the following precautions and instructions may result in death or serious personal injury. Property damage could also occur.

- Read and completely understand the safety precautions and instructions in this manual. Always follow all safety precautions and instructions, including those that are contained within the procedures of this manual.
- Read this manual before operating the cutter, or before performing any adjustments, inspections, maintenance or repairs.
- Follow all instructions and heed all precautions stated in this manual.
- Keep this manual for future reference in a place that is accessible to all persons operating or servicing the cutter.

- Always perform a visual inspection of the cutter before placing it into operation. If any problems are found, do not use the tool. Make repairs before using the cutter.
- Do not use the cutter if it is leaking oil. Do not use the cutter if damaged, altered or in need of repair.
- Do not remove or disable cutter safety devices. Before using the cutter, make sure that all the safety devices (guards, etc.) are in place and in good condition.
- Do not remove the guards installed on the cutter or on any accessories. Replace any guards immediately if they develop faults or become damaged.
- Do not alter the calibration of the safety devices, such as maximum pressure valves (if equipped).
- Allow only authorized, trained, and experienced personnel to operate the cutter and supervise its use.
- Ensure that all users are trained and qualified to operate the cutter. Operators must be aware of all applicable occupational safety laws and must operate the cutter in accordance with all such laws.
- Keep the work area clean and well illuminated.
- When operating the cutter, do not wear loose clothing or jewelry. These items could get caught up in the cutter during operation. Tie up long hair.
- Always wear and use appropriate personal protective equipment (PPE) such as non-skid safety shoes, hard-hat, hearing protection, and face and eye protection. Use of these and other PPE items (used as appropriate for the conditions) will reduce the chance of personal injuries. The use of these items may also be required by local regulations or laws.
- Consult your employer concerning specific safety requirements and the safety equipment required for use in your country or region.
- Before reaching inside the cutting area for any reason, always stop the pump, relieve hydraulic pressure and disconnect pump from AC power supply.
- Keep others clear of the work area while the tool is in use. Be sure that all personnel not operating the cutter remain at a safe distance when the cutter is in operation.
- Stop the cutter if people and/or animals enter the work area.
- Ensure that the operator is alert, observant of the task being performed and that the work is being done with care.
- Do not allow use of the cutter by persons that are tired, or under the influence of drugs, alcohol or medication.
- Do not allow children to operate the cutter or to assist with its use. Keep children out of the work area.
- Place the tool horizontally on a substantial work surface. The work surface must have a rated weight capacity that exceeds the weight of the cutter and of the material being cut.
- Fragments and splinters may be ejected from the cutter during normal use. The end of the material being cut may become a projectile as it separates during cutting. Stay clear of the shear blades and surrounding area during operation. Always wear face and eye protection.
- As needed, remove any foreign objects from the shear blades that could damage the cutter and/or injure the operator. Before removing any foreign objects, always stop the pump, relieve hydraulic pressure and disconnect pump from AC power supply.
- Avoid touching the cutter's metal surfaces during operation and after the cutter has been in use. Be aware of the risk of burns if the cutter becomes hot.
- Do not use the cutter for activities other than those it was approved and designed to perform. Refer to Section 7.1 of this manual for additional information regarding foreseen use.
- Use appropriately rated lifting equipment if it is necessary to lift the tool by mechanical means.
- Be certain that the properties of the material to be cut do not exceed the stated maximum limits applicable to your cutter model. Refer to Section 2.1 of this manual. Overloading may cause equipment failure and possible personal injury.
- Do not use the cutter in explosive atmospheres (for example, in the presence of flammable liquids, gasses or powders).
- Do not use the cutter on live electric lines, on pressure vessels or ducts, or on vessels containing corrosive and/or toxic substances.
- If the cutter malfunctions, stop use immediately. Check for misaligned or jammed moving parts, broken components and any other condition that could make the tool operate incorrectly. Place the cutter back into operation only after the fault has been identified and the identified repairs and/or adjustments have been performed.
- Ensure that any repairs are performed only by trained, qualified and authorized staff using original equipment replacement parts. For repair service, contact the Enerpac authorized service center in your area.
- Use only original equipment Enerpac parts. Enerpac parts are designed to fit properly and to withstand high loads. Non-Enerpac parts may break or cause the product to malfunction.
- Keep cutting tools clean and replace blades when they become dull. Suitably maintained cutting tools with sharp edges are less likely to jam and are easier to control.

### 1.3 General Hydraulic Tool Safety Precautions (Tools with external hydraulic pumps)

**⚠ WARNING** Failure to observe and comply with the following precautions and instructions could result in death or serious personal injury. Property damage could also occur.

- Always read, follow and completely understand all manufacturer's instructions when operating pumps, valves and all other devices used with the tool. Follow all safety precautions contained in the manufacturer's manuals.
- Use the tool only with a compatible Enerpac pump. Use of a non-compatible pump may result in erratic and/or unsafe operation.
- The tool is designed for a maximum working pressure of 10,150 psi [700 bar]. Do not connect the tool to a pump with a higher pressure rating. Be certain that all hydraulic hoses and fittings are properly connected and that they are rated at 10,150 psi [700 bar] or higher.
- Never set a relief valve to a higher pressure than the maximum rated pressure of the pump and tool. If ratings are different, relief valve setting should not exceed the setting of the lowest rated component (pump or tool).
- Perform cleaning, maintenance and repair operations only after disconnecting the tool from the hydraulic pump.
- Wear suitable personal protective equipment (PPE) such as goggles, gloves and protective clothing when checking hoses and fittings.
- Do not leave the tool unattended in the workplace when it is connected to the hydraulic pump.
- The tool is designed for noncontinuous use. Allow sufficiently long pauses to allow the oil to cool. Consult Enerpac if prolonged and/or interrupted use is required.
- Do not expose tool to temperatures in excess of 158°F [70°C]. Allow tool to cool or remove heat source.
- Be aware of hot metal components. Avoid contact with these components to prevent burns.
- Do not handle pressurized hoses. Escaping oil under pressure can penetrate the skin. If oil is injected under the skin, see a doctor immediately.
- Do not pressurize disconnected couplers.
- Never use a hydraulic cylinder or tool with uncoupled couplers.
- Do not remove or disable the pump relief valve. Do not remove or disable the tool relief valve (if equipped).
- Monitor the system hydraulic pressure gauge (or digital pressure readout). It is your window to see what is happening in the system.

- Always be certain that hydraulic pressure is fully relieved before disconnecting hydraulic hoses, loosening hydraulic fittings, or performing any tool disassembly or repair procedures.

**⚠ CAUTION** Failure to observe and comply with the following precautions and instructions could result in minor or moderate personal injury. Property damage could also occur.

- To help ensure proper operation and best performance, use only Enerpac HF hydraulic oil. Use of any other oil may result in unsafe operation and/or damage to tool. The Enerpac product warranty may also be invalidated.
- Be careful to avoid damaging hydraulic hoses. Avoid sharp bends and kinks when routing hydraulic hoses. Do not exceed the minimum bend radius specified by the hose manufacturer. Using a bent or kinked hose will cause severe back-pressure. Sharp bends and kinks will internally damage the hose, leading to premature hose failure.
- Do not drop heavy objects on hoses. A sharp impact may cause internal damage to hose wire strands. Applying pressure to a damaged hose may cause it to rupture.
- Do not lift hydraulic equipment by the hoses or couplers. Use the equipment handle(s) or lifting eye(s) (if equipped) and appropriately rated lifting equipment.
- Keep hydraulic equipment away from flames and heat. Excessive heat will soften packings and seals, resulting in fluid leaks. Heat also weakens hose materials and packings.
- Protect all hydraulic equipment from weld spatter.

### 1.4 Safety Symbols (on cutter)

**⚠ WARNING** Failure to observe and comply with the safety symbols affixed to the cutter housing could result in death or serious personal injury.

**⚠ WARNING** Make sure the safety symbols (decals, labels, etc.) are securely affixed to the tool and that they are legible. If not, obtain replacements from Enerpac. Refer to tool repair parts sheet for locations and part numbers. Failure to maintain safety symbols on tool could result in death or serious personal injury.

The following safety symbols are affixed to the cutter housing:



**Crush hazard:** Keep hands, fingers and other body parts away from the shear blades during operation.



**Projectile hazard:** Objects may be ejected from the cutter during operation. Stay clear of cutting area. Wear eye and face protection.



**PPE Alert:** Wear personal protective equipment (PPE) when using or servicing equipment.



**Instruction Manual Alert:** Read the instruction manual before using or servicing equipment.

### 1.5 Disconnecting Pump AC Power

**WARNING** Pump **MUST** be disconnected from the AC power supply before performing cutter maintenance, repair or cleaning procedures, or before allowing persons to reach inside the shear blades for any reason. Failure to observe this precaution may result in serious personal injury.

- Cutter will operate immediately when pump motor is running and the control knob is rotated.
- If it is not possible to unplug the pump power cord from the AC power outlet, turn off and lock out power at the AC power supply and disconnect the hydraulic hoses.
- Refer to the separate pump instruction sheet (provided with the pump) for detailed pump safety, operation and maintenance instructions.

### 1.6 Crush Hazard

**DANGER** Cutter will start immediately when pump motor is ON and the control knob is rotated.

**DO NOT** place hands, fingers or other parts of your body inside the shear blades unless pump is disconnected from AC power supply. Death or serious personal injury will result if cutter is operated while persons are working inside the shear blades.

- Never reach into the shear blades while cutter is in operation.
- Before reaching inside the shear blades for any reason, always stop the pump, relieve hydraulic pressure, and disconnect pump from AC power supply.

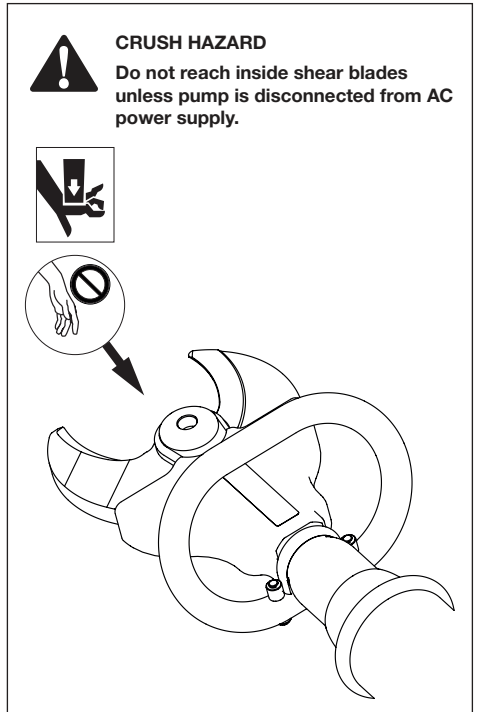

## 2.0 PRODUCT DATA

### 2.1 Cutter Maximum Capacities

Cutter Model No.	Material to be Cut	Material Maximum Tensile Strength		Material Maximum Hardness
		psi	daN/mm <sup>2</sup>	Rockwell C
EDCH130	Metal tubes, plate, cables and similar materials during decommissioning or demolition activities.	94,275	65	41
EDCH145		94,275	65	41
EDCH170		94,275	65	41

**NOTICE** Material to be cut must not exceed any of the stated maximum limits shown in this table.

These specifications are independent material limits provided to help prevent premature blade damage. They should not be considered as an indication of the maximum cutting capacity of the tool.

The tool will not necessarily cut the largest piece of material that will fit between the blades, even if the material properties are equal to or less than the stated maximum limits.

Cutting performance, including whether a cut can be completed, will depend on the material properties, blade condition, and the size and shape of the material being cut. If the tool is struggling or failing to make a cut, select a larger capacity tool.

### 2.2 Specifications

Cutter Model No.	Weight		Max. Hyd. Operating Pressure		Ambient Operating Temp		Hyd. Pump*
	lb	Kg	psi	bar	°F	°C	
EDCH130	25.4	11.5	10,150	700	-40 to +122	-40 to +50	External
EDCH145	37.3	16.9	10,150	700	-40 to +122	-40 to +50	External
EDCH170	53.4	24.2	10,150	700	-40 to +122	-40 to +50	External

**Notes:**

\* Hydraulic pump sold separately. Special Enerpac pump required. Refer to Section 6.1 for additional information.

Product specifications are subject to change without notice.

### 2.3 External Dimensions

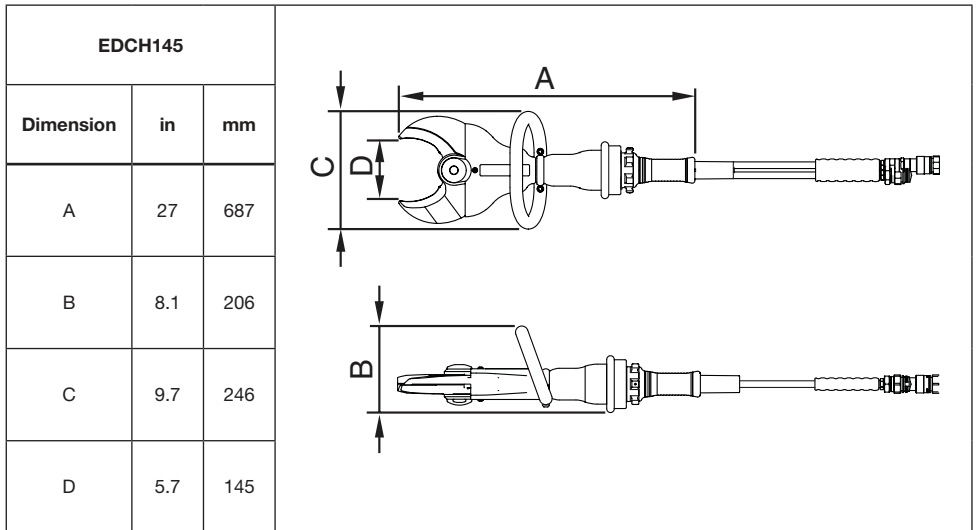
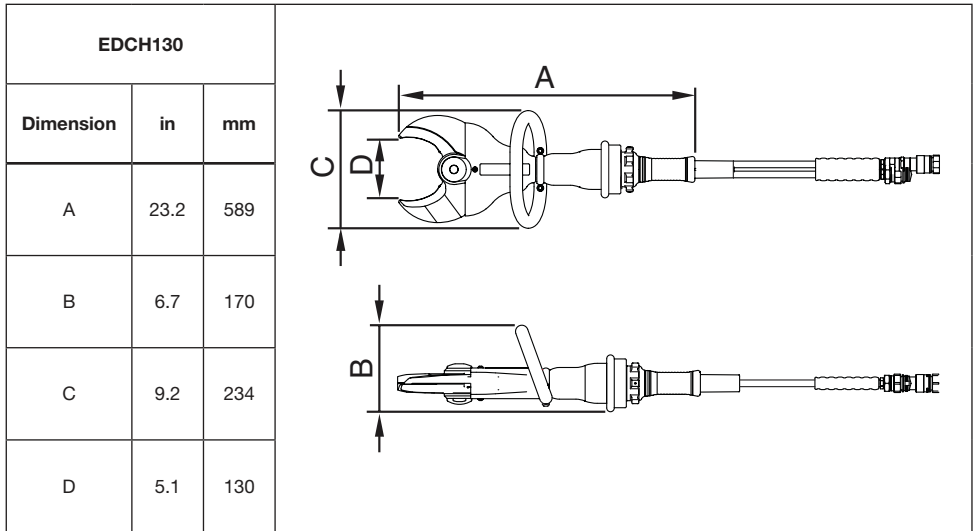

Product dimensions are subject to change without notice.

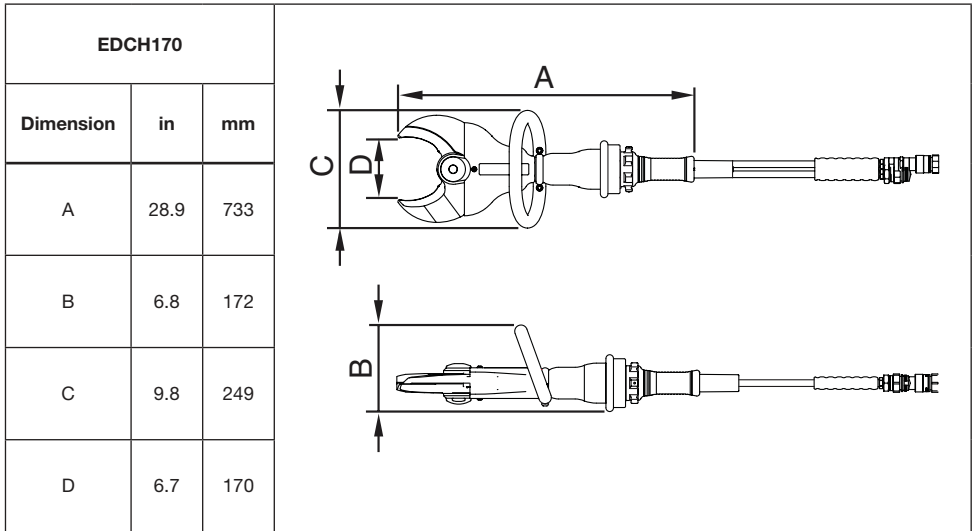

Product dimensions are subject to change without notice.

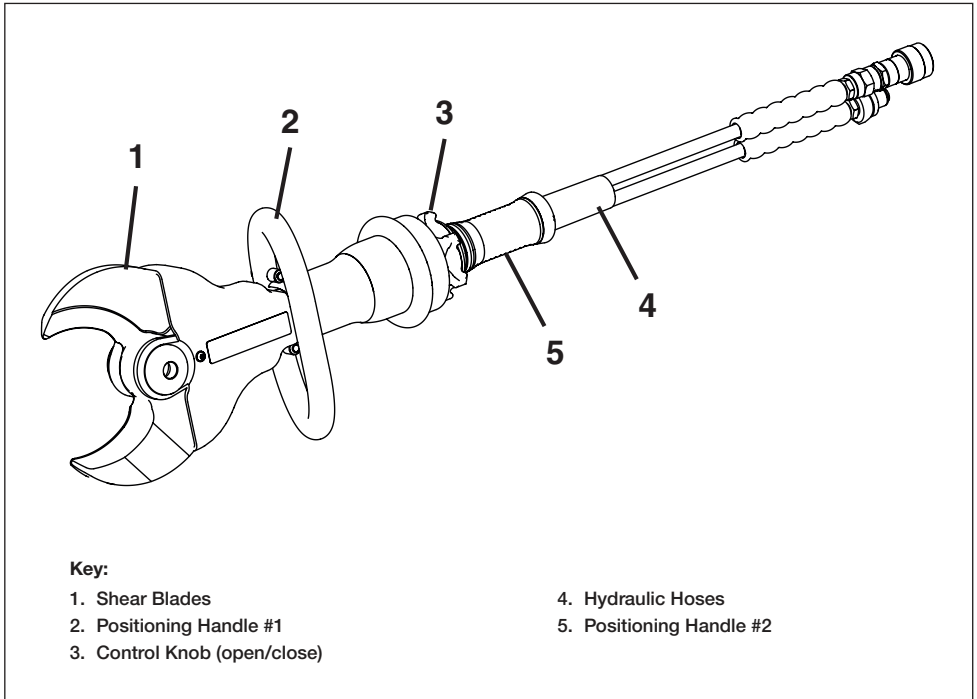

*Figure 1, Features and Components*

### 3.0 CONFORMANCE TO NATIONAL AND INTERNATIONAL STANDARDS



Enerpac declares that this product has been tested and conforms to applicable standards and is compatible with all CE requirements. A copy of an EU Declaration of Conformity is enclosed with each shipment of this product.

### 4.0 DESCRIPTION

Enerpac models EDCH130, EDCH145 and EDCH170 are fixed-head shear blade decommissioning cutters.

Hydraulic power is supplied by an Enerpac hydraulic pump, which is sold separately from the cutter. Refer to Section 6.1 for additional pump information.

See Figure 1 for a description of cutter major features and typical items included in the shipment. Refer to Section 2.0 for cutter maximum capacities, specifications and dimensions.

### 5.0 RECEIVING INSTRUCTIONS

Visually inspect all components for shipping damage. Shipping damage is not covered by warranty. If shipping damage is found, notify carrier at once. The carrier is responsible for all repair and replacement costs resulting from damage in shipment.

### 6.0 SET-UP

#### 6.1 Hydraulic Pump Requirements

The cutter must be used in conjunction with a specially designed hydraulic pump (sold separately). This pump contains unique valving and controls that are specific to the cutter.

Refer to the pump instruction sheet for detailed pump setup and operation instructions. Also refer to Section 6.3 of this manual for additional details.

#### 6.2 Hydraulic Connections

A high pressure twin hydraulic hose assembly connects the pump control valve to the cutter. This hose assembly is not included with the cutter and must be purchased separately. A chafe gear covering is also available as a separate accessory to help provide additional protection for the hoses.

To facilitate connections, quick-disconnect hydraulic couplers are present on the hoses, the cutter, and on the pump control valve.

**⚠ WARNING** Hydraulic oil can reach very high temperatures even when the cutter is idle and cutting force is not being applied. To prevent burns, always use suitable personal protective equipment when connecting or disconnecting couplers on a cutter that has been in operation.



**⚠ WARNING** Never use any hydraulic component that contains damaged hydraulic couplers. Never connect or disconnect a hydraulic coupler if the hydraulic circuit is pressurized. Failure to observe these instructions may result in the uncontrolled release of pressurized hydraulic oil. Skin penetration may occur. Death or serious personal injury could result.

**NOTICE** All hydraulic hoses and fittings used with the cutter must be rated at 10,150 psi [700 bar] or above.

### 6.2.1 Connecting the Hydraulic Couplers

1. Be sure that pump motor is stopped.
  2. Be certain there is no residual pressure in the hydraulic circuit. If pressure is present, discharge the pressure in accordance with the instructions in the pump instruction sheet.
- Repeat steps 3 through 6 for each hydraulic connection. See Figure 2 for hookup details.
3. Remove the coupler dust caps.
  4. Inspect the couplers after removing the dust caps. Remove any oil, dust or dirt.
  5. Push the male and female couplers firmly together until engagement occurs.
  6. Screw the threaded collar of the female coupler fully onto the threaded flange of the male coupler. Be sure that no threads are visible.

### 6.2.2 Disconnecting the Hydraulic Couplers

1. Be sure that pump motor is stopped.
2. Be certain there is no residual pressure in the hydraulic circuit. If pressure is present, discharge the pressure in accordance with the instructions in the pump instruction sheet.

Repeat steps 3 through 5 for each hydraulic connection. See Figure 2.

3. Unscrew the threaded collar of the female coupler from the threaded flange of the male coupler.
4. Disconnect the couplers. Remove any oil, dust or dirt.
5. Reinstall the coupler dust caps.

### 6.3 Pump Setup

Prepare the pump for operation as described in the pump instruction sheet.

Before connecting the pump to the cutter, verify that the pump relief valve is set at 10,150 psi [700 bar].

If the pump and/or cutter is being used for the first time, be certain to bleed air from the hydraulic system as described in Section 7.4 before using the cutter.

Verify that pump oil level is correct and that there are no oil leaks or other obvious problems.

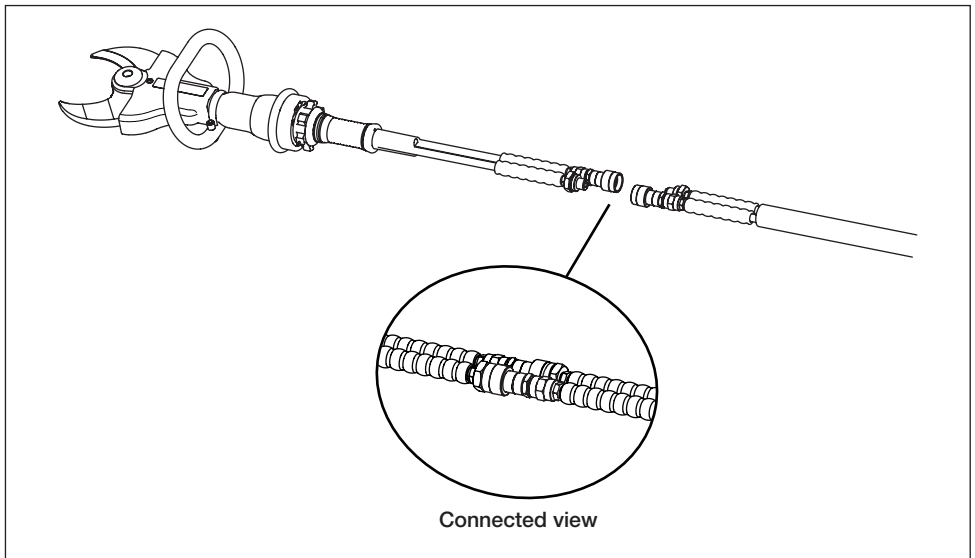

Figure 2, Hydraulic Connections at Cutter

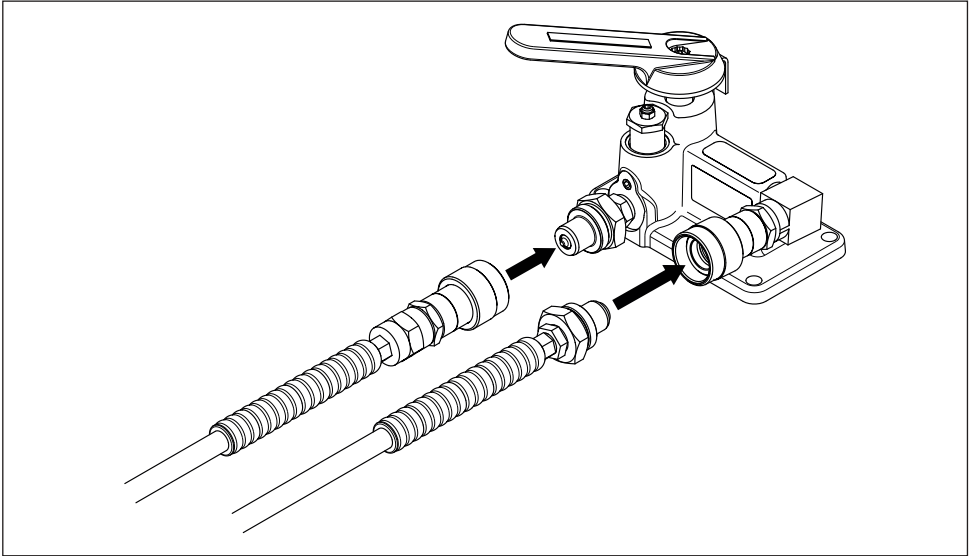

Figure 3, Hydraulic Connections at Pump

## 7.0 CUTTER OPERATION

### 7.1 Foreseen Use and Residual Risks

**⚠ WARNING** Failure to observe and comply with the instructions and precautions contained in the following paragraphs could result in death or serious personal injury.

1. The cutter is designed for cutting metal tubes, plate, cables and similar materials during decommissioning or demolition activities.

The properties of the material to be cut must not exceed the stated maximum limits applicable to your cutter model. Refer to Section 2.1.

2. The cutter may be used only when connected to a compatible Enerpac hydraulic pump.

3. Operators must observe the instructions in this manual in order to minimize the risk of accidents. In particular, operators must pay attention when working in conditions that could cause:

- Possible burns from overheated parts.
- Injury due to incorrect positioning or inadequate lifting or moving.
- Injury caused by splinters discharged from the bar or other work piece.

**⚠ WARNING** People remaining in the vicinity of the cutter while it is working are subject to the risk of flying debris (dangerous objects, etc.). Serious personal injury could result.

4. Incorrect Uses:

- Cutter must not be used for purposes other than those indicated in this document.
- Cutter must not be used in areas subject to the risk of explosion.

### 7.2 Positioning the Cutter

• Before inserting material to be cut inside the blades, be certain that the cutter is positioned on a solid and stable work surface of sufficient weight rating capacity. Refer to Section 2.2 for cutter weight.

• Position the cutter as needed using the positioning handles located at the side and rear of the cutter hydraulic cylinder. See Figure 1.

• If it is necessary to move or transport the cutter, use the positioning handles and, if needed, properly rated lifting equipment.

**⚠ WARNING** Because the cutter components are very heavy, there is a risk of cuts, crushing or broken bones. To avoid accidents, use care when working with the cutter. Serious personal injury may result if the cutter is not properly supported and handled in an appropriate way.

### 7.3 Operating Precautions

**⚠ WARNING** Failure to observe the following precautions and instructions could result in death or serious personal injury.

- Keep fingers, hands and other body parts clear of the blades.
- Do not attempt to reposition the item being cut while the cutter is in operation. Always stop the cutter and then move the blades to the open position before repositioning the item.
- Dangerous projectiles could occur at any time during cutting. Always wear face and eye protection. Keep persons away from cutting area.
- Cutter surfaces can become very hot. To prevent burns, avoid contact with cutter components and wear appropriate personal protective equipment.
- Refer to additional safety precautions in Section 1.0 of this manual before using the cutter or performing any maintenance or repair activities.

### 7.4 Trapped Air Removal

Before placing a new cutter into operation, cycle the piston several times without load to remove any trapped air in the hydraulic circuit. The tool should also be placed below the pump so the air can escape to the pump reservoir.

Air is completely purged when the piston advances and retracts smoothly in both directions, from fully extended to fully retracted.

This procedure may also be performed after the cutter has been serviced.

Refer to the cutter controls information in Section 7.6 of this manual when performing the air removal procedure.

### 7.5 Positioning Material

Position the material to be cut between the cutter blades so that it is perpendicular to the blade axis, as shown in Figure 4. This will provide the best quality cut.

Position the material at the base of the blades. Do not position the material at the tips of the blades.

**NOTICE** Be certain that the properties of the material to be cut do not exceed the stated maximum limits applicable to your cutter model. Refer to Section 2.1 of this manual for additional information. Failure to observe the instruction may result in poor cutting performance and/or damage to the cutter.

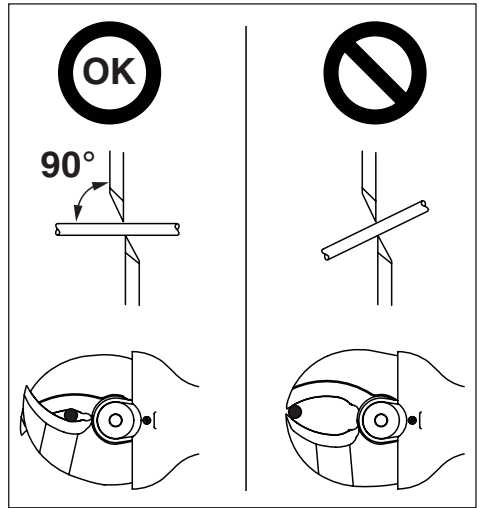

Figure 4, Positioning Material in the Blades

### 7.6 Cutter Controls

The control knob is used to open and close the blades. The control knob will center itself between the open and closed positions in the neutral position.

- To open the blades: Rotate the knob to the left and hold it in place. See Figure 6.
- To close the blades: Rotate the knob to the right and hold it in place. See Figure 7.
- To stop blade movement: Release the knob at any time. The knob will automatically return to the neutral position. See Figure 5.

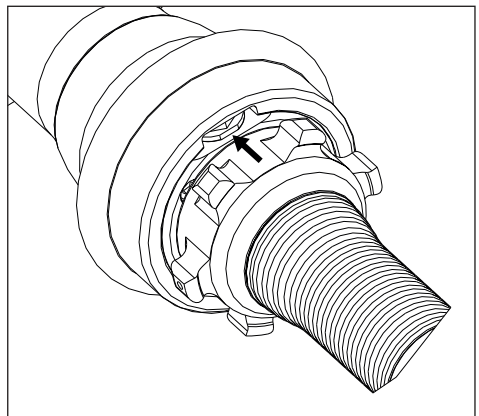

Figure 5, Neutral Position

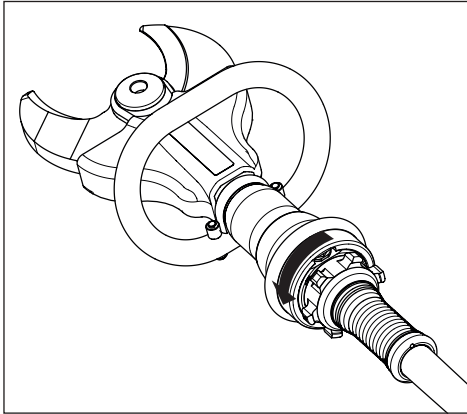

Figure 6, Cutter Open

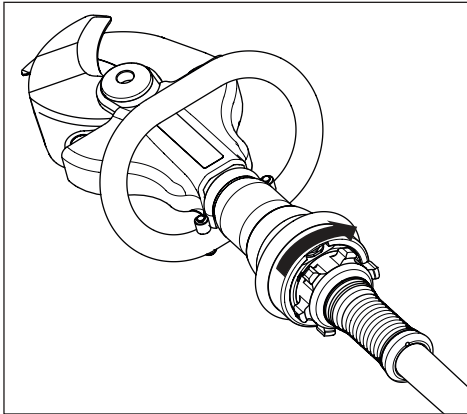

Figure 7, Cutter Closed

## 7.7 Cutting Procedure (typical)

1. Be certain that the properties of the material to be cut do not exceed the stated maximum limits applicable to your cutter model. Refer to the chart in Section 2.1 of this manual.
2. Place the material to be cut between the blades. Be sure that it is perpendicular to the blade axis, as shown in Figure 4. Refer to instructions in Section 7.5 for additional information.

**NOTICE** Failure to properly position the material in the shear blades may result in blade breakage and reduced cutting efficiency.

3. Start the pump motor.
4. Turn the control knob to the right and hold it until the item has been fully cut.
5. Turn the control knob to the left and hold it until the blades are opened to the desired position.
6. Release the control knob. The control knob will move to the neutral position and the blades will stop opening.

## 8.0 MAINTENANCE

### 8.1 Periodic Maintenance Table

Refer to the Periodic Maintenance Chart (Table 1) for a list of various routine checks and procedures.

**WARNING** Disconnect pump from AC power supply before performing any cleaning, maintenance or repair procedures. Failure to observe this precaution could result in death or serious personal injury.

### 8.2 Cleaning

Clean the cutter using a dry cloth or compressed air. For plastic surfaces, use a cloth slightly dampened with water.

**CAUTION** To prevent possible injury, always wear safety glasses or face mask when using compressed air.

- Be sure there are no traces of oil, grease or corrosive substances on the tool, especially on the grips.
- Use a damp cloth and soapy water to clean plastic components.
- Do not use gasoline or thinner to clean the tool.

**Table 1 - Periodic Maintenance Chart**

Time Interval	Maintenance Operation	Method	To be performed by:
Every 8 hours of operation:	Check the cutter for loose, damaged or worn parts. Check for oil leaks. Tighten, replace or repair as required.	Visual	Operator
	Clean the cutter.	(Refer to instructions in Section 8.2)	Operator
	Check that screws and bolts are properly tightened. Replace any missing screws or bolts.	(Refer to instructions in Section 8.3)	Operator

### 8.3 Fasteners

Periodically check all screws, nuts and other fasteners for proper tightness. Tighten any loose fasteners. Replace any worn or damaged fasteners. This should be performed periodically or every day in the event of frequent or prolonged cutter operation.

**NOTICE** Failure to check and tighten fasteners as required may result in serious damage to the cutter.

### 8.4 Preparation for Maintenance

All cutter maintenance procedures must be performed under the following conditions:

- All hydraulic pressure must be relieved. Refer to the pump instruction sheet for pressure relief procedure.
- The pump must be disconnected from the AC power supply.
- The cutter must be given time to cool to prevent burns.
- Procedures must be performed in a suitable work environment in accordance with all current safety regulations and/or laws in your country or region.
- The cutter must be cleaned thoroughly before maintenance procedures are performed.
- Suitable personal protective equipment (PPE) must be used and/or worn while performing any work.

## 9.0 STORAGE

### 9.1 Storage Guidelines

If the cutter will be stored for an extended period of time:

- Disconnect hydraulic hoses from cutter. Be sure that dust caps are installed on hydraulic couplers.
- Thoroughly clean the cutter.
- Lubricate the cutter metal surfaces with a thin layer of oil.
- Store the cutter in a clean and dry place, accessible only to authorized personnel.

### 9.2 Return to Use (after storage)

Before using the cutter after an extended period of storage or inactivity, perform the following steps:

- Remove protective oil coating (applied before storage) from cutter surfaces.
- Check for oil leaks. Make repairs as required.
- Check that the tool hydraulic hoses are intact and undamaged.
- Check for any missing, worn or improperly installed parts.
- Check that all screws, nuts, bolts and other fasteners are tight.
- Replace, repair or tighten components as needed.

## 10.0 TROUBLESHOOTING

Refer to the Cutter Troubleshooting Chart (Table 2) for a list of common hydraulic cutter symptoms, possible causes and solutions.

For repair service, contact an Enerpac authorized service center. Inspection and repairs should be performed only by an Enerpac authorized service center or other qualified hydraulic tool service facility.

**Table 2 - Cutter Troubleshooting Chart**

Symptom	Possible Cause	Solution	Maint. Level
1. Blades move slowly and/or have difficulty cutting the material.	Excessive cutting debris on the blades.	Clean out debris.	Operator
	Blocked or restricted hydraulic oil flow.	Check for incomplete hydraulic connections, blocked hydraulic hoses or other similar problems.	Operator
	Low hydraulic oil level.	Check oil level. Add oil if low.	Operator
	Material being cut is outside of acceptable specifications.	Material properties must not exceed stated maximum limits. Refer to Section 2.1.	Operator
	Blade wear.	Replace blades.	Service Center
	Low hydraulic oil pressure or flow.	Check pump relief valve setting. Troubleshoot and repair pump and solenoid control valve (as required).	Service Center
	Cutter seal wear and/or internal damage.	Repair cutter as required.	Service Center
2. Cutter vibrates during operation.	Loose or missing screws or bolts.	Verify screws and bolts are properly tightened. Replace any missing screws or bolts.	Operator
3. External oil leaks.	Loose hydraulic fittings.	Tighten loose fittings.	Operator
	Damaged hydraulic hoses.	Replace hoses.	Operator
	Damaged hydraulic couplers.	Replace couplers.	Service Center
	Worn or damaged cutter components.	Repair cutter as required.	Service Center



**ENERPAC**   
[WWW.ENERPAC.COM](http://WWW.ENERPAC.COM)