

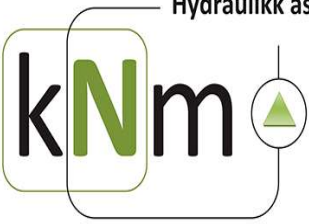

Hydraulikk as



Torque and tension specialist

<b>ENERPAC</b> 	<b>Instruction Sheet</b>
	<b>GT Series Hydraulic Tensioners</b>

L2714    Rev. D    10/19

For other languages go to [www.enerpac.com](http://www.enerpac.com).

Weitere Sprachen finden Sie unter [www.enerpac.com](http://www.enerpac.com).

Para otros idiomas visite [www.enerpac.com](http://www.enerpac.com).

Muunkieliset versiot ovat osoitteessa [www.enerpac.com](http://www.enerpac.com).

Pour toutes les autres langues, rendez-vous sur [www.enerpac.com](http://www.enerpac.com).

Per altre lingue visitate il sito [www.enerpac.com](http://www.enerpac.com).

Ga voor de overige talen naar [www.enerpac.com](http://www.enerpac.com).

For alle andre språk henviser vi til [www.enerpac.com](http://www.enerpac.com).

Inne wersje językowe można znaleźć na stronie [www.enerpac.com](http://www.enerpac.com).

Para outros idiomas consulte [www.enerpac.com](http://www.enerpac.com).

För andra språk, besök [www.enerpac.com](http://www.enerpac.com).

L2714 Rev. D 10/19

#### CONTENTS

1.0 INTRODUCTION.....	1
2.0 SAFETY .....	2
3.0 SPECIFICATIONS.....	4
4.0 FEATURES AND COMPONENTS.....	4
5.0 SETTING UP.....	6
6.0 INSTALLATION .....	6
7.0 TENSIONING AND DE-TENSIONING .....	10
8.0 MAINTENANCE.....	15
9.0 STORAGE.....	18
10.0 TECHNICAL DATA .....	19

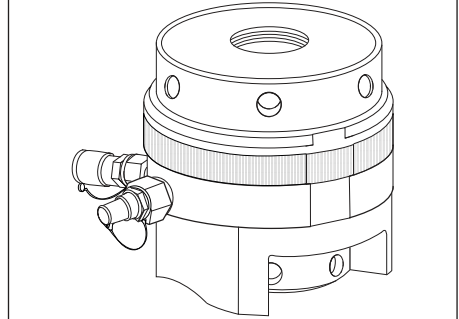

## 1.0 INTRODUCTION

### Overview

The Enerpac GT Tensioner has been designed for the controlled and accurate application of a pre-determined load to a nut and bolt assembly.

In use, GT Tensioners are attached to the stud bolts of a joint assembly; in either a uniform or alternating arrangement, as required by the application to be tensioned. The GT Tensioner can also be used for a single stud bolt application.

GT Tensioners are to be used as part of a complete hydraulic system, alongside an electric pump and hose arrangement.

The series can be used on a wide range of bolt size and pressure requirements.

### Delivery Instructions

Upon delivery all components must be inspected for damage incurred during shipping. If damage is found the carrier should be notified at once. Shipping damage is not covered by the Enerpac warranty.

### Warranty

- Enerpac guarantees the product only for the purpose for which it is intended.
- Refer to the Enerpac Global Warranty document for terms and conditions of the product warranty.

Any misuse or alteration invalidates the warranty.

- Observe all instructions as communicated in this manual.
- When replacement parts are needed, use only genuine Enerpac replacement parts.

Modification to any part of the equipment outlined in this manual should not be attempted, nor any component part be replaced without first consulting Enerpac. Modifications may render the equipment dangerous. Component parts are each rated to suit the demands of the overall equipment design and replacement with similar items without provenance may lead to unexpected and dangerous accidental features.

If any equipment abuse is evident, the warranty will be invalidated and Enerpac will not be made responsible for an injury due to misuse or failure to comply with the above safety notes.

## EU Declaration of Conformity

GT1 •GT2 •GT3 •GT4 •GT5 •GT6 •GT7



These tools conform with the requirements for CE.

Enerpac declares that this product has been tested and conforms to applicable standards and is compatible to all CE Requirements.

A copy of an EU Declaration of Conformity is enclosed with each shipment of this product.

## 2.0 SAFETY

Read all introductions carefully. Follow all recommended safety precautions to avoid personal injury as well as damage to the product and / or damage to other property. Enerpac cannot be responsible for any damage or injury from unsafe use, lack of maintenance, or incorrect operation. Do not remove warning labels, tags, or decals. In the event of any questions or concerns arising, contact Enerpac or a local Enerpac distributor for clarification.

If you have never been trained on high-pressure hydraulic safety, consult your distributor or service centre for information about Enerpac Hydraulic Safety Courses.

This manual follows a system of safety alert symbols, signals, words, and safety messages to warn the user of specific hazards. Failure to comply with these warnings could result in death or serious personal injury, as well as damage to the equipment or other property.

The Safety Alert Symbol appears throughout this manual. It is used to alert you to potential physical injury hazards. Pay close attention to Safety Alert Symbols and obey all safety messages

that follow this symbol to avoid the possibility of death or serious injury.



Safety Alert Symbols are used in conjunction with certain Signal Words that call attention to safety messages or property damage messages and designate a degree or level of hazard seriousness. The Signal Words used in this manual are WARNING, CAUTION, and NOTICE.

 **DANGER** Indicates a hazardous situation that, if not avoided, **will** result in death or serious personal injury.

 **WARNING** Indicates a hazardous situation that, if not avoided, **could** result in death or serious personal injury.

 **CAUTION** Indicates a hazardous situation that, if not avoided, **could** result in minor or moderate personal injury.

 **NOTICE** Indicates information considered important, but not hazard related (e.g. messages in relation to property damage). Please note that the Safety Alert Symbol will **not** be used with the signal word.

### 2.1 Safety Precautions - GT Tensioners



**Failure to observe and comply with the following precautions could result in death or serious personal injury. Property damage could also occur.**

- Read and completely understand the safety precautions and instructions in this manual before operating the tensioners or preparing them for use. Always follow all safety precautions and instructions, including those that are contained within the procedures of this manual.
- When the system is under pressure DO NOT STAND IN LINE with the direction of force of the tensioners. Keep this area clear of personnel at all times when the system is under pressure. If the bolt should fail, serious personal injury or death could result if loose or broken parts become projectiles.

- Operating procedures will vary, depending on the system arrangement. Always read, follow and completely understand all manufacturers' instructions when operating pumps, valves and all other devices used with the tensioners. Follow all safety precautions contained in the manufacturer's manuals. Use only for intended purpose.
- Wear personal protective gear when operating hydraulic equipment. Always wear eye protection. Safety equipment such as dust mask, non-skid safety shoes, hard hats, gloves or hearing protection (used as appropriate) will reduce personal injuries.
- Ensure that the strengths of the bolts are known and that the recommended tensioning applied loads are well within the safe limits.
- Do not handle pressurized hoses. Escaping oil under pressure can penetrate the skin. If oil is injected under the skin, see a doctor immediately.
- Do not pressurize disconnected couplers.
- The system operating pressure must not exceed the pressure rating of the lowest rated component in the system.
- Install pressure gauge(s) in the system to monitor operating pressure. It is your window to see what is happening in the system.
- Never set a relief valve to a higher pressure than the maximum rated pressure of the pump and tensioner. If ratings are different, relief valve setting should not exceed the setting of the lowest rated component (pump or tensioner).
- Do not exceed equipment ratings. Never attempt to apply more load to a bolt than the maximum capacity of the tensioner. Overloading may cause equipment failure and possible personal injury.

**⚠ CAUTION**

**Failure to observe and comply with the following precautions could result in minor or moderate personal injury. Property damage could also occur.**

- Be careful to avoid damaging hydraulic hoses. Avoid sharp bends and kinks when routing hydraulic hoses.
- Do not bend beyond the minimum bend radius specified by the hose manufacturer. Using a bent or kinked hose will cause severe back-pressure. Sharp bends and kinks will internally damage the hose, leading to premature hose failure.
- Do not lift hydraulic equipment by the hoses or couplers. Use the tensioner lifting eye-bolts and appropriately rated lifting equipment, where appropriate.
- Keep hydraulic equipment away from flames and heat. Excessive heat will soften packings and seals, resulting in fluid leaks. Heat also weakens hose materials and packings.
- For optimum performance, do not expose hydraulic equipment to temperatures of 150°F [65°C] or higher.
- Immediately replace worn or damaged parts with genuine Enerpac parts. Enerpac parts are designed to fit properly and to withstand high loads. Non-Enerpac parts may break or cause the product to malfunction.
- Use hydraulic tensioners only in a coupled system. Never use a tensioner with uncoupled couplers.

**NOTICE**

- Hydraulic equipment must only be serviced by a qualified hydraulic technician. For repair service, contact the Enerpac Authorized Service Centre in your area.
- Rope off working area and place warning signs.
- To help ensure proper operation and best performance, use of Enerpac oil is strongly recommended.

### 3.0 SPECIFICATIONS

Major tensioner specifications, such as maximum working pressure, maximum load and maximum stroke are stamped into the side of the hydraulic tensioner body. See Figure 1. Be aware of these specifications during installation and set-up.

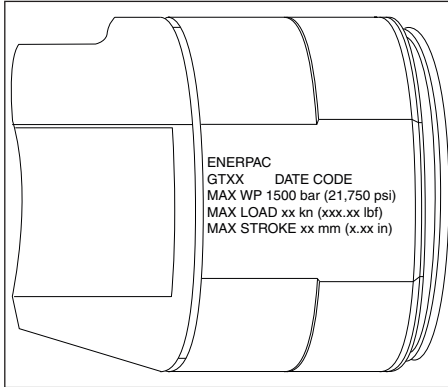

FIGURE 1, TENSIONER DATA

### 4.0 FEATURES AND COMPONENTS

Refer to Figure 2 for a diagram of GT Series Tensioner major components.

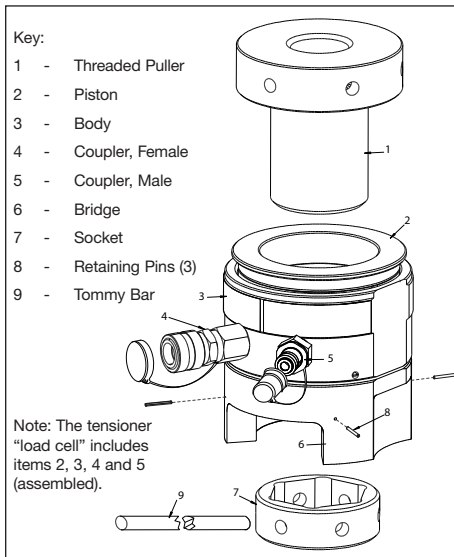

FIGURE 2, TENSIONER MAJOR COMPONENTS

#### 4.1 Maximum Stroke Indicator

Maximum allowable tensioner stroke is visually indicated by a yellow painted groove located on the piston's circumference. See Figure 3.

Continually watch for the maximum stroke indicator during tensioning procedures. Stop pressurizing the system immediately if the indicator becomes visible.

If during any tensioning procedure, the maximum stroke indicator appears before the desired hydraulic pressure is reached: STOP the pump, tighten nut(s) at the tensioner(s) and release hydraulic pressure. Then, turn down the threaded puller(s) to return the piston(s) back into the tensioner(s).

To ensure proper tensioning, always repeat the tensioning stage (start over) if the maximum stroke indicator appears before the desired hydraulic pressure is reached.

**⚠ WARNING** Continuing to pressurize the system after the maximum stroke indicator becomes visible may result in high pressure hydraulic oil leakage. Serious personal injury could result if a stream of pressurized hydraulic oil penetrates the skin. Damage to tensioner components and joint may also occur if maximum stroke is exceeded.

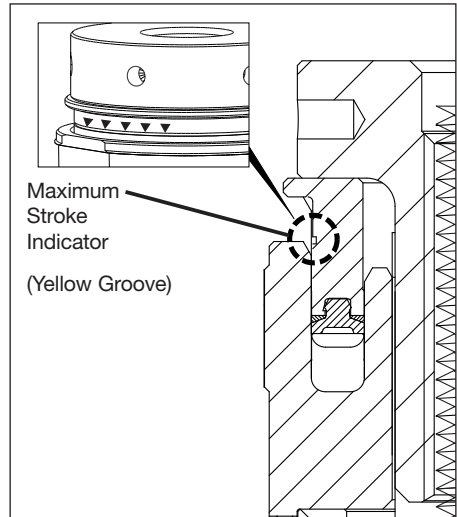

FIGURE 3, MAXIMUM STROKE INDICATOR

## 4.2 Socket Captivation Feature

**Note:** If the bridge and socket were manufactured prior to 2019 and they have a Date Code of A, they will not have the socket captivation feature.

**Note:** If the tensioner and adaptor kit are purchased together, items will be supplied with the socket in the captivated position.

### Captivated Socket Assembly

Refer to Figure 2 to identify if the GT Tensioner has the captivated socket feature.

The captivated socket has a groove machined into the outer wall. The bridge has also been updated to include three holes equally spaced to insert the retaining pins that secure the socket within the bridge and allow it to rotate freely.

### Assemble Captivated Socket and Bridge

1. Rotate the bridge so the bottom is facing upwards. See Figure 4, View A.
2. Insert the socket with the machined groove at the bottom of the socket. See Figure 4, View A.
3. Insert the retaining pins supplied with the tensioner into the bridge using a soft mallet and a suitable sized pin insertion tool. See Figure 4, View B.
4. Insert retaining pin into position until it is flush with the outer wall of the bridge wall. Repeat insertion process for the two remaining retaining pins.
5. Check that the socket is restrained and freely moving before installation and tensioning.

### Remove captivated socket from bridge

1. Rotate the bridge so the bottom is facing upwards. Identify retaining pin removal hole in socket. Rotate the socket until this feature is in line with the retaining pin. See Figure 4, View C.
2. Using a soft face mallet and a suitable sized roll pin punch tool, gently remove the retaining pin by tapping it through the bridge wall and through the removal hole into the centre of socket. See Figure 4, View C.
3. Rotate the socket and repeat removal process for the other two retaining pins.
4. The socket can now be freely removed from the bridge.

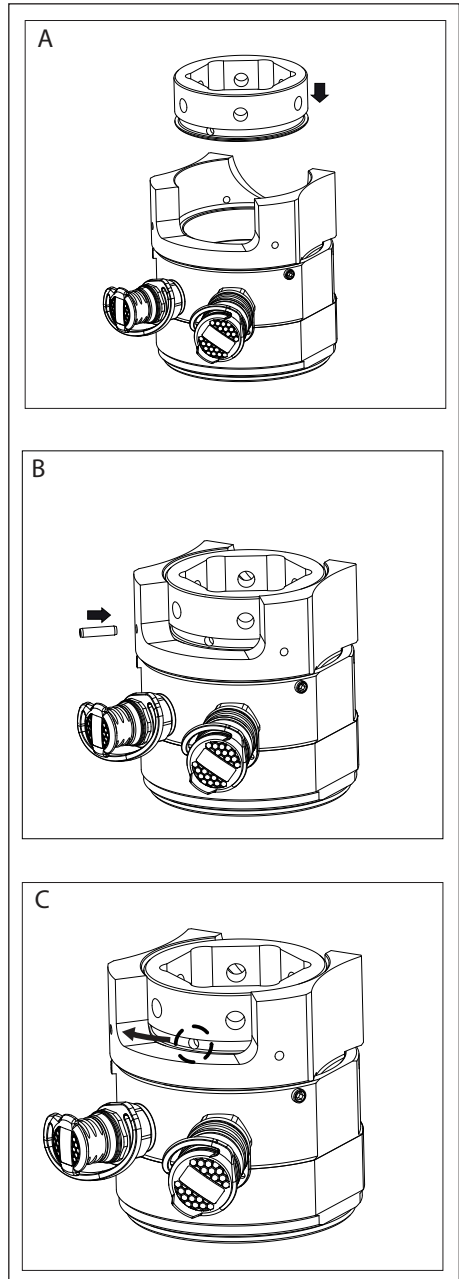

FIGURE 4, INSTALL/ REMOVE CAPTIVATED SOCKET

## 5.0 SETTING UP

### 5.1 Hydraulic Oil

Oil requirements will vary, depending on pump model and type. Refer to your pump instruction manual for oil specifications. Failure to use genuine Enerpac hydraulic oil may void warranty.

### 5.2 Hoses and Fittings

All hydraulic hoses and fittings used in the circuit must be rated at or above the maximum working pressure of the tensioner - 21,750 psi [1500 bar].

To ensure safe and reliable operation, use of Enerpac approved high pressure hoses is strongly recommended. Refer to the Enerpac Bolting Solutions Catalog for a complete list of available hoses, fittings and related accessories.

### 5.3 Pump Requirements

This bolt tensioning equipment has been designed to be used in conjunction with a hydraulic pump unit. Enerpac can offer a range of pump options to suit particular applications and thus operators should refer to the specific instruction manual for the pump to be used. The safety rationale used in the design of this tensioner has assumed a pump maximum working pressure appropriate for the tool and using hydraulic oil Enerpac HF oil ISO32. Enerpac HF oil is available at your local Enerpac Distributor or Authorized Service Centre.

Hydraulic connection is made using quick disconnect male & female couplers. In the event an alternative pump unit is used, additional safety measures such as pressure relief valves or bursting discs must be considered to ensure over-pressurisation cannot occur.

The following are recommended pump parameters:

AIR SUPPLY : 1/2" nominal bore supply line

AIR CONSUMPTION: 28 CGFM at 100 psi

AIR PRESSURE: 80 - 100 psi (80 psi optimum)

See pump manual for operating instructions.

## 6.0 INSTALLATION

### 6.1 Before You Begin

1. Be sure that ALL calculations (bolt load, hydraulic pressure, etc.) have been made prior to starting the tensioning process and that they have been reviewed and approved by a qualified engineer with bolting experience.
2. Be sure all personnel involved in this procedure are trained in joint tightening procedures and the tensioning equipment being used. Ensure that all personnel read and understand the safety information contained in sections 2.1 and 2.2 of this document.
3. Be sure that the pump reservoir oil capacity is adequate for the number of tensioners to be used in the circuit. Refer to Table 1 for tensioner oil volumes.
4. Be sure all personnel are aware of the maximum working pressure and maximum stroke applicable to the tensioner(s) being used. This information is stamped on the tensioner body. See Section 3.0 for additional information.
5. Inspect the studs to verify that they contain no obvious damage or defects, and that they appear capable of withstanding the force that will be applied by the tensioners.

Table 1 - Tensioner Oil Volumes

Series	Maximum Oil Volume at Maximum Stroke (each tensioner)	
	fluid ounces (US)	cubic centimeters
GT1	0.65	19.4
GT2	1.16	34.5
GT3	2.25	66.7
GT4	3.95	117.0
GT5	5.84	173.9
GT6	7.63	225.9
GT7	10.72	317.2

Note: To determine total oil volume required, multiply the oil volume for your tensioner series by the number of tensioners to be used in the circuit. Oil volumes shown are approximate. Additional oil will be contained inside hoses and fittings.



6. Be sure that all nuts and threaded pullers are free running on the studs over the entire stud length protruding through the joint.
7. Check that each stud is correctly installed and that there is sufficient stud extension to engage the tensioner. The exposed portion of the stud (above the nut) should be at least the same dimension as the stud diameter. The total protruding length of the stud (from joint surface to end of stud) must be at least twice the length of the exposed portion of the stud. See Figure 5.

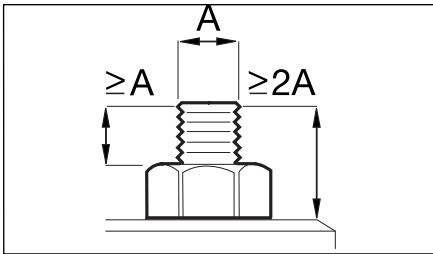

FIGURE 5, STUD EXTENSION REQUIREMENTS

## 6.2 Tensioner Installation and Hook-up

1. Refer to Section 6.1, Before You Begin. All personnel to be involved in tensioning procedures must read, understand and follow the instructions contained in Section 6.1.
2. Determine the tensioner arrangement around the joint surface. Refer to Section 6.3 for examples and additional information.
3. Before installing the first tensioner, be sure that the threaded portions of the stud and threaded puller are clean and free of damage.
4. Place the tensioner over the stud, ensuring that the socket fits over the nut without force. See Figure 6, View A.
  - a. Ensure that the tommy bar slot in the bridge faces outward.
  - b. Ensure that the hydraulic couplers are positioned outward, to allow easier connection of hydraulic hoses.

**Note:** GT bridges and sockets manufactured prior to 2019 and which have a Date Code of A, will not have the socket captivation feature. For GT Tensioners with a Date Code of A, position the socket over the nut; ensure that the socket fits over the nut without force. Place the tensioner over the stud.

5. Locate the end of the stud with the threaded puller. Using a tommy bar, screw down the threaded puller on the stud until the puller shoulder seats firmly against the piston. See Figure 6, View B.
6. Assemble any additional tensioners in the system in the same manner, following steps 3 through 6 of this section.
7. Check that the pump pressure release valve is OPEN. See Figure 6, View C.
8. Connect hydraulic hoses to the tensioners. See Figure 6, views D and E. Also refer to Section 6.3 for typical hose connection arrangements.
9. At each stud, verify that the piston is fully retracted into the tensioner body. If necessary, turn down the threaded puller (as required) to fully retract the piston.
10. Before pressurizing the system, be sure that all hydraulic hoses are connected. Each male coupler must be connected to a corresponding female coupler. Verify that each coupler is fully engaged and securely locked into position by physically pulling on the connection.

**IMPORTANT:** ONLY the unused female coupler on the LAST tensioner at the end of the circuit can remain disconnected. A blanking plug must be installed in this coupler before beginning pressurization.

**⚠ WARNING** Never pressurize the back side of a disconnected (open ended) male coupler. Disconnected male couplers may leak when pressurized from the back side. **Serious personal injury could result if leakage occurs, and a high pressure oil stream penetrates the skin.**

**⚠ WARNING** If only a single tensioner is being used, always pressurize the tensioner using ONLY the MALE tensioner coupler. To prevent possible high pressure oil leakage, NEVER use the female tensioner coupler to pressurize a single tensioner.

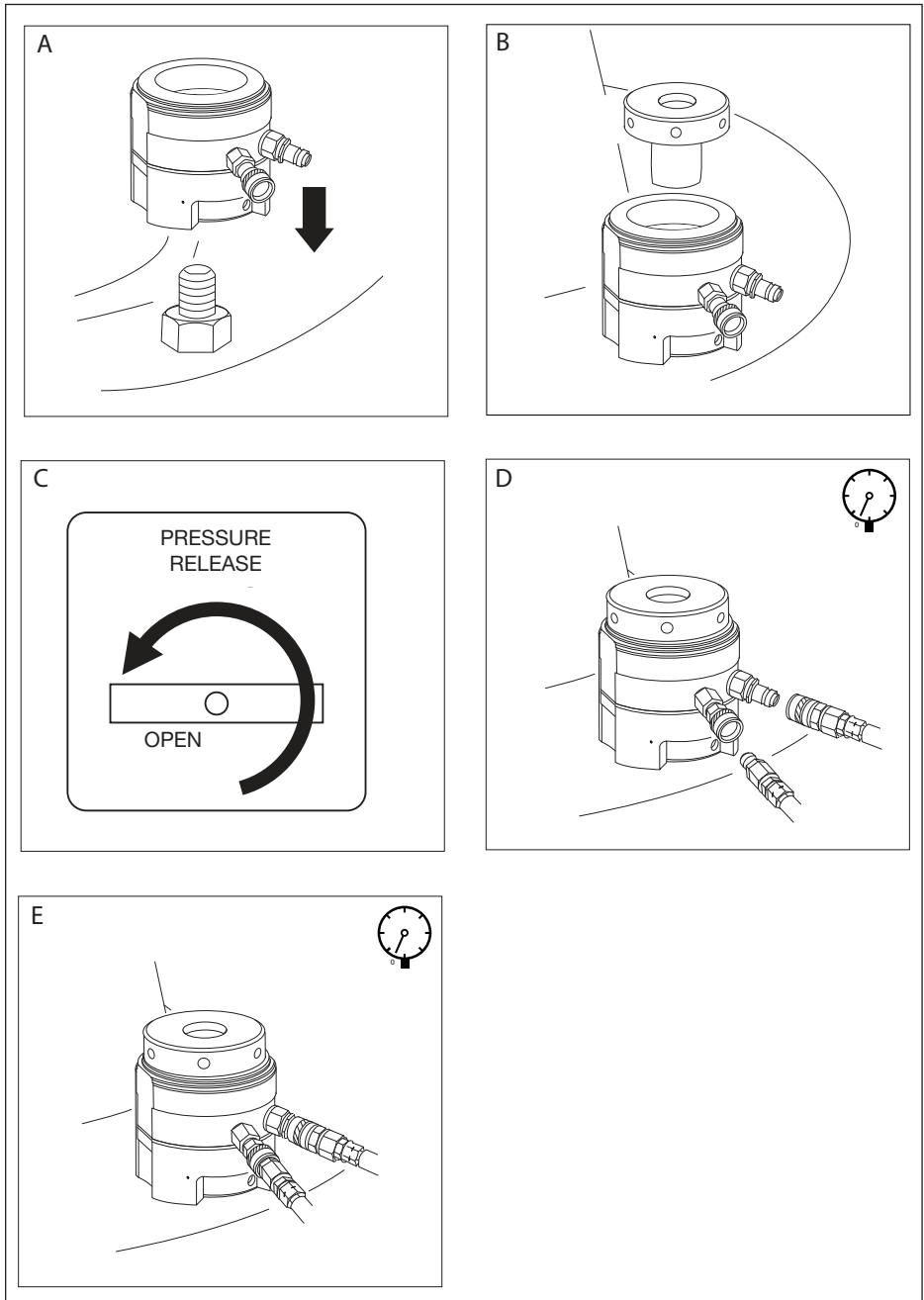

FIGURE 6, HYDRAULIC TENSIONER INSTALLATION

### 6.3 Tensioner Arrangements (typical)

Hydraulic tensioners can be mounted on either one or both sides of the joint, depending on available clearance and work room. Whenever possible, all studs on the joint should be tensioned at the same time. Typical examples of 100% and 50% tensioner coverage are shown in Figure 7. Contact Enerpac for additional information regarding tensioner arrangements of less than 50% coverage.

**Note:** For less than 100% coverage, divide the quantity of tensioners available into the quantity of studs in the joint. This will determine the stud locations to be tightened during each pass. For example, if 18 tensioners are available for a 36 bolt joint, then every second stud will contain a tensioner (50% coverage). If 12 tensioners are available, then every third stud will contain a tensioner (33% coverage).

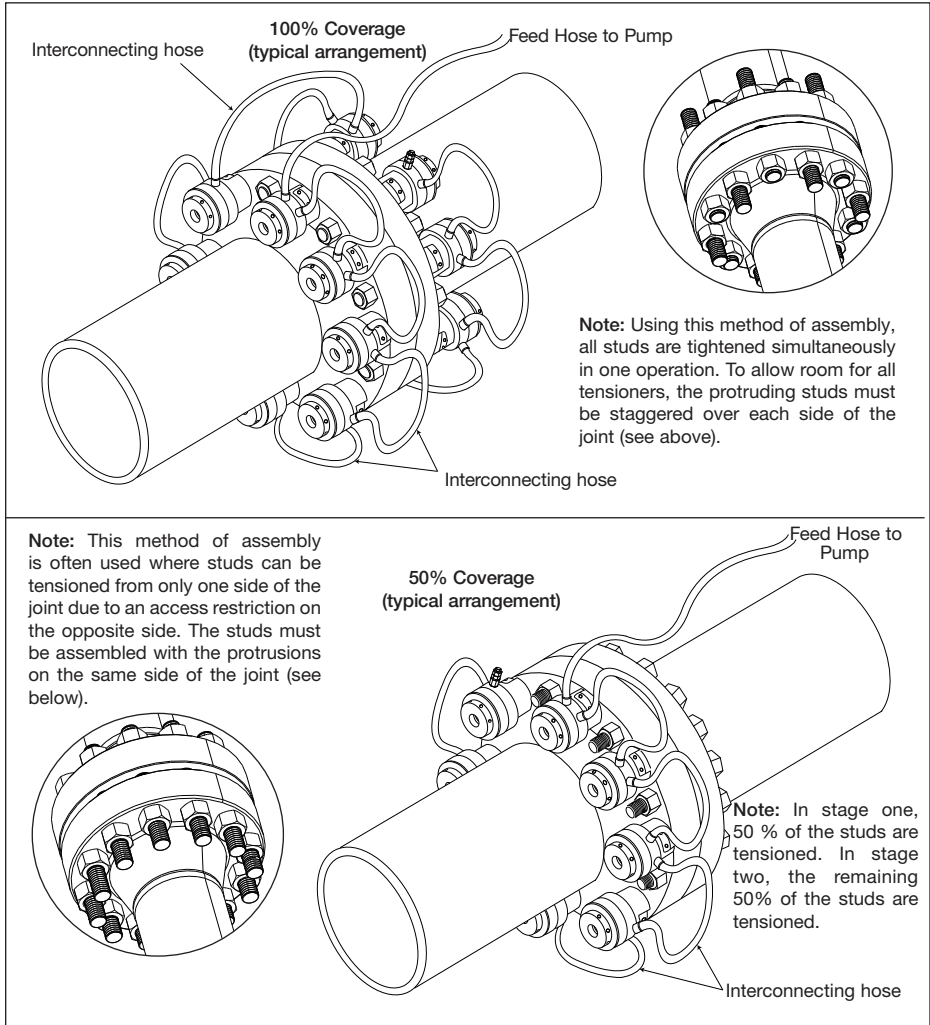

FIGURE 7, HYDRAULIC TENSIONER MOUNTING ARRANGEMENTS (TYPICAL)

## 7.0 TENSIONING AND DE-TENSIONING

Never stand in-line with the bolt axis while the system is pressurized. If the bolt should fail, serious personal injury or death could result if loose or broken parts become projectiles. All personnel must be aware of this potential hazard at all times.

**WARNING** Ensure that the maximum working pressure and maximum stroke are not exceeded. Refer to the specifications stamped on the tensioner body. Also see Table 2 at the end of this document.

**IMPORTANT:** If the maximum stroke indicator appears at any time during the following procedures, immediately STOP the pump, tighten nut(s) at the tensioner(s) and release hydraulic pressure. Then, turn down the threaded puller(s) to return the piston(s) back into the tensioner(s) before continuing. Refer to Section 4.1 for additional information.

**IMPORTANT:** If any leaks occur, immediately stop the pump and open the pressure release (return-to-tank) valve. Be sure that the oil pressure gauge indicates zero (0) psi/bar. Make repairs as required before continuing with tensioning procedures.

**Note:** For improved illustration clarity, only one hydraulic hose is shown connected to the tensioner in figures 7 to 11.

### 7.1 Tensioning Instructions - 100% Coverage (tensioner installed on each stud)

**IMPORTANT:** Read precautions and instructions at beginning of Section 7.0 before beginning the following steps. Also refer to safety information contained in Section 2.0.

1. Ensure that the joint is correctly aligned.
2. Assemble the tensioner(s) to the stud(s) and connect hydraulic hoses. Refer to sections 6.1 and 6.2 for additional tensioner installation and hose connection instructions.
3. Determine the required hydraulic tensioning pressure. This value must be calculated by a qualified engineer with bolting experience.
4. Operate the pump and pressurize the tensioners up to approximately 1000 psi [70 bar]. Check for oil leaks.

5. If no leaks are found, continue pressurizing the tensioners to the calculated value determined in step 3. Continually observe the tensioner stroke and hydraulic pressure at all times during pressurization.
6. When the calculated hydraulic pressure is reached, stop the pump. Recheck the oil pressure gauge after pump has stopped. Be sure the pressure is stable (not increasing or decreasing). Threads may be visible between the nut and the joint surface at each tensioner. See Figure 8.
7. While holding the pressure constant, use a tommy bar to turn down the first socket and nut by hand. Continue tightening until the nut is firmly seated against the joint surface. See figures 9 and 10.
8. Repeat step 7 for all remaining studs in the circuit.

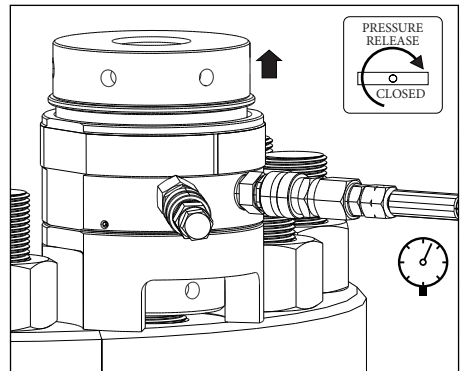

FIGURE 8, PRESSURIZING THE TENSIONER

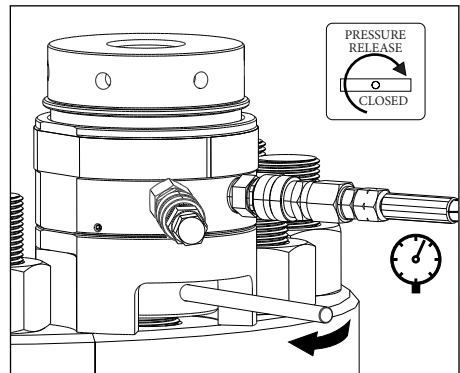

FIGURE 9, TURNING DOWN THE SOCKET AND NUT

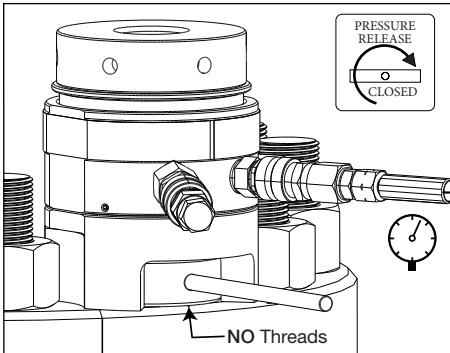

FIGURE 10, SOCKET AND NUT FIRM AGAINST JOINT

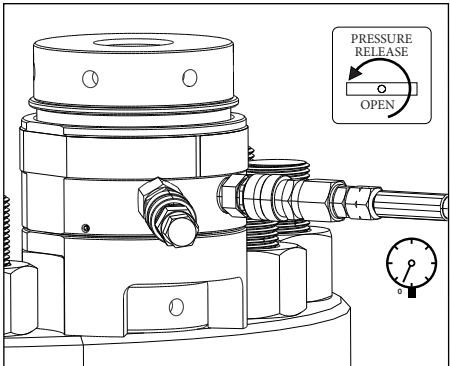

FIGURE 11, PRESSURE RELEASED AFTER TURNING DOWN NUT

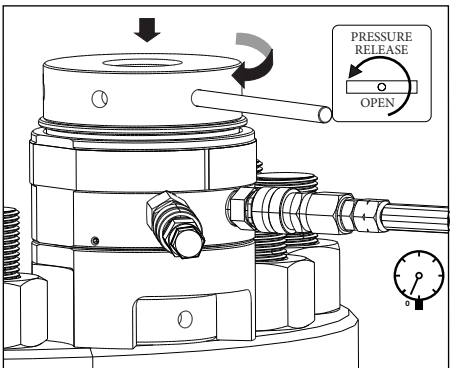

FIGURE 12, TURNING DOWN THE THREADED PULLER (AS REQUIRED)

9. Release the hydraulic pressure by SLOWLY opening the pump pressure release (return to tank) valve. Verify that the oil pressure gauge indicates zero (0) psi/bar. See Figure 11.
10. Check the piston stroke. If necessary, turn down the threaded puller until the piston is fully retracted into the tensioner body. See Figure 12.
11. Repeat steps 4 through 10 a second time.
12. Repeat steps 4 through 10 a third time.
13. As an optional check, apply hydraulic pressure a fourth time and attempt to tighten the nuts again.
  - If the nuts cannot be turned, then tensioning is complete. Relieve hydraulic pressure. Go to Step 14.
  - If the nuts can still be turned, repeat steps 4 through 10 until no additional movement can be obtained. **However, caution must be observed as excessive movement may indicate that a joint problem exists.**
14. Verify that the oil pressure gauge indicates zero (0) psi/bar. If any pressure is indicated, release the hydraulic pressure by SLOWLY opening the pump pressure release (return to tank) valve.
15. Turn down the threaded pullers until the pistons are fully retracted. Disconnect hydraulic hoses and install a dust cap (not shown) over each disconnected coupler. Remove tensioners from the studs.

## 7.2 Tensioning Instructions - 50% Coverage (tensioner installed on every other stud)

**IMPORTANT:** Read precautions and instructions at beginning of Section 7.0 before beginning the following steps. Also refer to safety information contained in Section 2.0.

1. Ensure that the joint is correctly aligned.
2. Alternately number each bolt "1" and "2" for future reference.
3. Assemble the tensioner(s) to the studs marked "1" and connect the hydraulic hoses. See Figure 13 for typical tensioner arrangement. Also refer to sections 6.1 and 6.2 for additional tensioner installation and hook-up instructions.

- Determine the “first pass” pressure “A” value. This value must be calculated by a qualified engineer with bolting experience.

**Note:** The pressure “A” value used to tension the bolts marked “1” is typically *higher* than the pressure “B” value used later to tighten the bolts marked “2”. This is to allow for additional load losses which may occur when performing less than 100% coverage tensioning.

- Operate the pump and pressurize the tensioners up to approximately 1000 psi [70 bar]. Check for oil leaks.
- If no leaks are found, restart the pump and pressurize the tensioners to the “first pass” pressure “A” value determined in step 4. Continually observe the tensioner stroke and hydraulic pressure at all times during pressurization.
- When the “first pass” pressure “A” is reached, stop the pump. Recheck the oil pressure gauge after pump has stopped. Be sure the pressure remains stable (not increasing or decreasing). Threads may be visible between the nut and the joint surface at each tensioner. See Figure 8.
- While holding the pressure constant, use a tommy bar to turn down the first socket and nut by hand. Continue tightening until the nut is firmly seated against the joint surface. See figures 9 and 10.
- Repeat step 8 for the remaining “first pass” tensioners in the circuit.
- Release the hydraulic pressure by SLOWLY opening the pump pressure release (return to tank) valve. Verify that the oil pressure gauge indicates zero (0) psi/bar. See Figure 11.
- Check the piston stroke at each tensioner in the circuit. If necessary, turn down the threaded puller until the piston is fully retracted into the tensioner body. See Figure 13.
- Repeat steps 5 through 11 a second time (to pressure “A”).
- Repeat steps 5 through 11 a third time (to pressure “A”).
- Move the tensioners to the remaining 50% of the bolts (i.e. all bolts numbered “2”). See Figure 14.

- Determine the “second pass” pressure “B” value. This value must be calculated by a qualified engineer with bolting experience.

**Note:** The pressure “B” value is typically *lower* than the pressure “A” value (see note after step 4 for additional information).

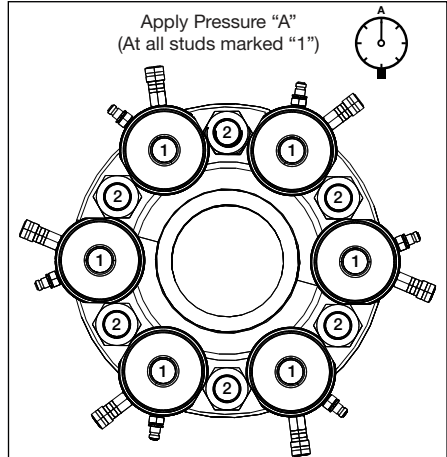

FIGURE 13, TENSIONER ARRANGEMENT, FIRST PASS - TYPICAL (50% TENSIONER COVERAGE)

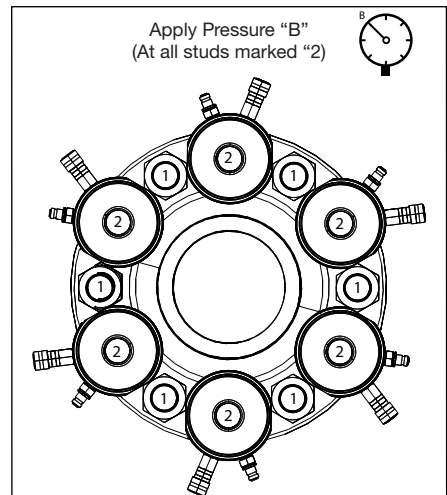

FIGURE 14, TENSIONER ARRANGEMENT SECOND PASS - TYPICAL (50% TENSIONER COVERAGE)

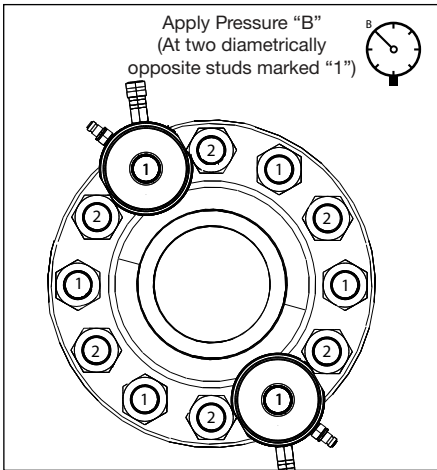

FIGURE 15, RECHECKING FIRST PASS TENSIONER (50% TENSIONER COVERAGE)

16. Operate the pump and pressurize the tensioners up to approximately 1000 psi [70 bar]. Check for oil leaks.
17. If no leaks are found, continue pressurizing the tensioners to the calculated “second pass” pressure “B” value determined in step 15. Continually observe the tensioner stroke and hydraulic pressure at all times during pressurization.
18. When the “second pass” pressure “B” is reached, stop the pump. Recheck the oil pressure gauge after pump has stopped. Be sure the pressure remains stable (not increasing or decreasing). Threads may be visible between the nut and the joint surface at each tensioner. See Figure 8.
19. While holding the pressure constant, use a tommy bar to turn down the first socket and nut by hand. Continue tightening until the nut is firmly seated against the joint surface. See figures 9 and 10.
20. Repeat step 19 for the remaining “second pass” tensioners in the circuit.
21. Release the hydraulic pressure by SLOWLY opening the pump pressure release (return to tank) valve. Verify that the oil pressure gauge indicates zero (0) psi/bar. See Figure 11.

22. Check the piston stroke at each tensioner in the circuit. If necessary, turn down the threaded puller until the piston is fully retracted into the tensioner body. See Figure 12.
  23. Repeat steps 16 through 22 a second time (to pressure “B”).
  24. Repeat steps 16 through 22 a third time (to pressure “B”).
  25. As an optional check to determine if an excessive load has been lost in the first 50% of bolts tightened (bolts numbered “1”):
    - a. Assemble tensioners on any two “first pass” bolts (labeled “1”) located diametrically opposite of each other. See Figure 15.
    - b. Connect hydraulic hoses.
    - c. Apply the “second pass” pressure “B”.
    - d. Using the tommy bar, attempt to tighten the nuts on these bolts by hand.
      - If the nuts cannot be turned, then tensioning is complete. Relieve hydraulic pressure. Go to step 26.
      - If the nuts can be turned, then re-install the tensioners to the remainder of the “first pass” bolts (numbered “1”), apply the “second pass” pressure “B” and turn-down the nuts one more time as described in steps 16 through 22.
  26. Verify that the oil pressure gauge indicates zero (0) psi/bar. If any pressure is indicated, release the hydraulic pressure SLOWLY by opening the pump pressure release (return to tank) valve.
  27. Turn down the threaded pullers until the pistons are fully retracted. Disconnect hydraulic hoses and install a dust cap (not shown) over each disconnected coupler. Remove tensioners from the studs.
- 7.3 De-tensioning Instructions - 100% Coverage (tensioner installed on each stud)**

**IMPORTANT:** Read precautions and instructions at beginning of Section 7.0 before beginning the following steps. Also refer to safety information contained in Section 2.0.

**Note:** For improved illustration clarity, only one hydraulic hose is shown connected to the tensioner in figures 16-19.

1. Assemble the tensioner(s) to the stud(s) to be de-tensioned and connect the hydraulic hoses. Refer to sections 6.1 and 6.2 for additional tensioner installation and hose connection instructions.
2. BEFORE applying any hydraulic pressure, turn up the threaded puller at each stud as required, so that approximately a 3/16 inch [5 mm] gap appears between the fully retracted piston and the threaded puller. See Figure 16.
3. Operate the pump to pressurize the tensioners up to approximately 1000 psi [70 bar]. Check for oil leaks.

**⚠ WARNING** In the following de-tensioning steps, be certain that the hydraulic pressure remains below the maximum allowable hydraulic pressure of 21,750 psi [1500 bar], and that the load applied does not exceed the tensile strength of the stud.

4. If no leaks are found, continue operating the pump. Slowly raise the pressure until the “break loose” hydraulic pressure value is reached. This is the pressure at which a nut on one of the tensioners just begins to loosen and can be turned by hand with the tommy bar. Record this pressure for reference. See Figure 17.
5. Increase the hydraulic pressure approximately 5 percent above the “break loose” pressure recorded in step 4. Then, stop the pump.
6. While holding the pressure constant, turn up (loosen) the nut at the first tensioner, so that there is approximately a 1/8 inch [3-4 mm] gap between the nut and the joint surface. See Figure 18.

**Note:** Dimension of gap in step 6 must not exceed the dimension of gap in step 2.

7. Repeat step 6 at all remaining studs.

**⚠ CAUTION** If nuts are difficult to turn, hydraulic pressure may be increased in additional 5 percent increments. However, NEVER raise hydraulic pressure above 21,750 psi [1500 bar]. Ensure that the load applied does not exceed the tensile strength of the stud.

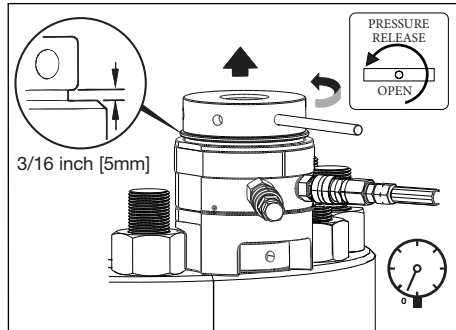

FIGURE 16, TURNING UP THE THREADED PULLER

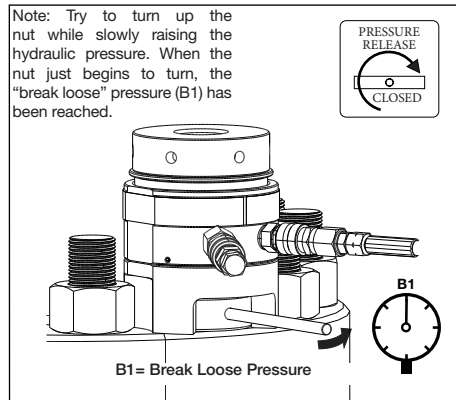

FIGURE 17, DETERMINING THE “BREAK LOOSE” PRESSURE

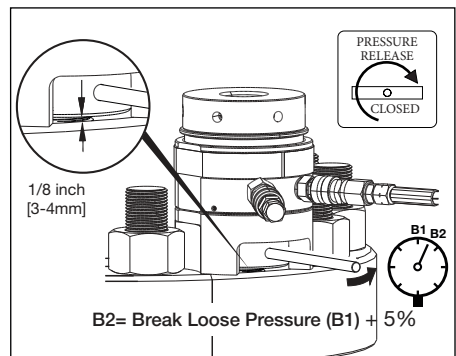

FIGURE 18, TURNING UP THE NUT



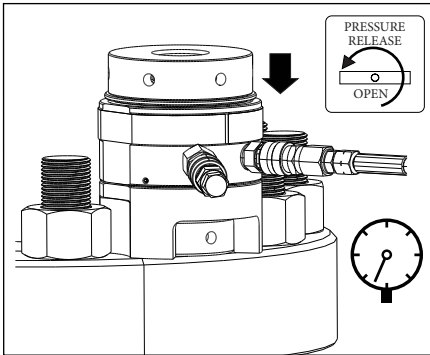

FIGURE 19, PRESSURE RELEASED - NUT DE-TENSIONED

8. Release the hydraulic pressure by SLOWLY opening the pump pressure release (return to tank) valve. Verify that the oil pressure gauge indicates zero (0) psi/bar. See Figure 19. The studs are now fully de-tensioned.
  9. Turn down the threaded pullers until the pistons are fully retracted. Disconnect hydraulic hoses and install a dust cap (not shown) over each disconnected coupler. Remove tensioners from the studs.
- 7.4 De-tensioning Instructions - 50% Coverage (tensioner installed on every other stud)**

**IMPORTANT:** Read precautions and instructions at beginning of Section 7.0 before beginning the following steps. Also refer to safety information contained in Section 2.0.

1. Assemble the tensioner(s) to the first 50% of stud(s) to be de-tensioned and connect the hydraulic hoses. Refer to sections 6.1 and 6.2 for additional tensioner installation and hose connection instructions.
2. Follow steps 2 through 8 of Section 7.3 for the first 50% of studs.
3. Move the tensioners to the second 50% of studs.
4. Follow steps 2 through 9 of Section 7.3 for the remaining 50% of studs. Note that the “break loose” hydraulic pressure for the second set of studs will likely be about the same or slightly lower than that for the first set.

## 8.0 MAINTENANCE

It is recommended that repairs and servicing be carried out by Enerpac at intervals agreed by Enerpac and customer. All parts will be thoroughly inspected and replaced where necessary, certain components (e.g. seals) will be replaced automatically. Tensioners will be re-assembled, pressure tested and a test certificate issued.

Note: All parts will have been manufactured, inspected and tested in accordance with Enerpac’s stringent requirements. Any parts failing in use that are found upon Enerpac’s inspection not to be Enerpac’s genuine spare parts will invalidate any operative warranty or guarantee.

The tool is of rugged construction and utilises reliable seals. The only maintenance that may be occasionally required is the replacement of seals or repair of a hydraulic fitting.

Note: It is strongly recommended that in the event of seal failure the tensioners are returned to Enerpac for seal replacement, however if this is not possible then the enclosed procedure should be followed.

### 8.1 Pre-Use Maintenance

Assemble the tensioner onto a suitable bolt (see Section 6.0), check that the bolt material is capable of taking the applied load i.e. do not pressurise to max working pressure if the bolt is not strong enough to withstand the full load of the tool.

Pressurize for approximately one minute, a pressure drop of 50 bar is acceptable during this time.

If the tensioner passes this test, then the ram should be reset and the tensioner is ready for use.

If any leakage is noticed within the head assembly, then a full strip down will be necessary to change the seals, as described in Section 8.4.

### 8.2 Post-Use Maintenance

In order to keep the equipment in good working condition it is important that at the end of each period of use, prior to being replaced into dry storage, a post-use maintenance is carried out.

## 1. GT Tensioner

The ram should be reset and all parts should be cleaned down, and coated with WD40 or similar. Alternatively rinse in light oil.

Replace the dust caps on the quick disconnect couplers to prevent the ingress of dirt.

If any leakage is noticed within the head assembly, then a full strip down will be necessary to change the seals, as described in Section 8.4. If tensioners are subject to a lot of use it is advisable to fully strip them and clean and inspect all components, at least once a year. Refer to Section 8.3.

## 2. Bridge

Ensure that the socket is free to rotate inside the bridge.

Ensure that the socket retaining pins are intact. Inspect for damage and clean down with light oil before storing.

## 3. Puller

Ensure that the threads are free from damage by screwing it down a suitably sized bolt.

Clean down the puller with light oil before storing.

## 4. Hoses and Ancillaries

Clean, then coat each quick disconnect coupler in a water repellent spray such as WD40 or similar, retracting and releasing the collars several times. Ensure that the collars do not seize in the retracted position. Visually inspect the entire length of the hose for damage. Test to maximum working pressure (ensure blanking plugs inserted into end of coupler).

### 8.3 GT Tensioner Full Maintenance/ Servicing

It is recommended that repairs and servicing be carried out by Enerpac at intervals agreed by Enerpac and customer. All parts will be thoroughly inspected, specified parts will be non-destructively tested using MPI techniques and replaced where necessary, certain components (e.g. seals) will be replaced automatically.

Tensioners will be re-assembled, pressure tested and a test certificate issued.

Note: All parts will have been manufactured, inspected and tested in accordance with Enerpac's stringent requirements. Any parts failing in use that are found upon Enerpac's inspection not to be Enerpac's genuine spare parts will invalidate any operative warranty or guarantee.

Remove the bridge assembly from the head assembly. Inspect each sub assembly for any visible damage/leaks etc.

With the ram fully retracted in the head assembly, unscrew the quick disconnect couplers.

Replace the seals as described in Section 8.4.

Refit the springs, spring housing and quick disconnect couplers.

Clean the puller, particularly the thread, and bridge assembly (if necessary remove the retaining pins and socket).

Assemble the tensioner onto a suitable bolt (see Section 6.2) check that the bolt material is capable of taking the applied load i.e. do not pressurise to max working pressure if the bolt is not strong enough to withstand the full load of the tool. Pressurize for approximately one minute, a pressure drop of 50 bar is acceptable during this time. Having removed the tensioner from the bolt, coat each sub-assembly in a water repellent spray such as WD40 or similar.

Replace the dust caps on the quick disconnect couplers.

## 8.4 Changing Tensioner Seals

### 1. Precautions

The following precautions must be taken with the assembly of the hydraulic seals:

- Avoid sharp edges (cover thread areas)
- Remove all dust, dirt, swarf and foreign particles.
- Do not use sharp edged tools.
- Lubricate all components before assembly.

Hydraulic seal replacement must only be carried out should the seals become damaged. The seals should not be removed during routine maintenance.

## 2. Ram

### Legend for Figures

1. Seal
2. Ram
3. Anti-Extrusion Ring (AER)
4. Pliers
5. Blunt Edged Dolly

## 3. Seal Removal

Fit an open-ended female quick-disconnect coupler to a tensioner coupler. Using the flat blade of a screwdriver, lever the piston out of the tensioner body.

To remove the hydraulic seals and Anti-Extrusion Rings (AER's):

Using a pair of pliers, grip the sealing lip of the hydraulic seal and pull the seal away from the ram. Take care not to damage the edge of the ram.

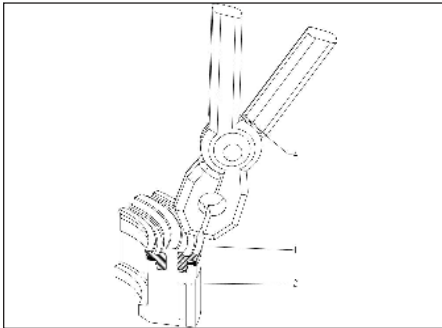

FIGURE 20 - REMOVAL OF SEALS

Discard the seal, remove the extraction bolts and replace the two plastic grub screws.

## 4. Seal Replacement

Inspect the seal housing grooves within the ram. Using either a clean cloth or compressed air, remove all dirt and debris from the ram and body. It is very important that all dust and debris be removed from the seal/AER as failure to do so may result in seal failure.

Fit the AER's to the seal, the tapered surface of the AER must face the taper of the seal as shown below. This applies to both outer and inner AER's.

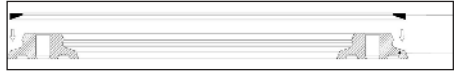

FIGURE 21 - AER LOCATION

Install the seal assembly into the ram, pressing down firmly until the seal fully enters the ram seal housing.

Engage the seal retaining clip by pushing down around the periphery using a blunt edged dolly in the position shown below. A 'click' will be sensed when the seal fully engages.

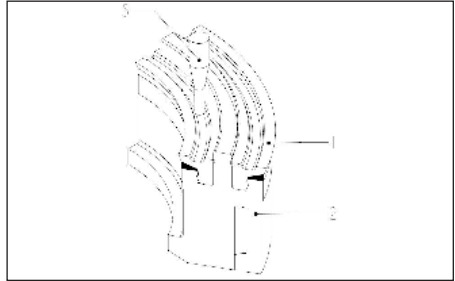

FIGURE 22 - ENGAGING THE SEAL

When there are no gaps between the ram, AER and seal the assembly is correct, see below.

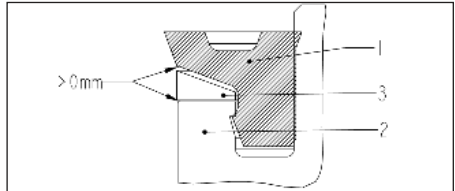

FIGURE 23A - INCORRECT AER ASSEMBLY

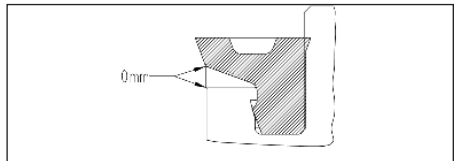

FIGURE 23B - CORRECT AER ASSEMBLY

Lubricate the seal and tensioner bores with silicone grease or clean hydraulic oil in preparation of installing the ram.

Push the ram into the body bore ensuring that the seal does not become nipped. The outer seal will be the first to enter and can be used as a guide to square up the ram prior to entering the inner seal. Should difficulty be encountered in entering seals, a slight rotation of the ram whilst pushing the ram into the body may aid the installation.

#### 5. Coupler Seals - 1/4" BSP Fittings

A simple sealing arrangement exists between the GT tensioner body and the coupler. The seal is a 21,750 psi [1500 bar] rated Bonded Seal; it is located inside a counterbore on the tensioner body behind the coupler. Should the seal leak or become damaged then it should be replaced as follows.

Unscrew the male quick-disconnect coupler.

Note: A 1/4" BSP threaded adaptor is fitted into the male quick-disconnect coupler. Under normal circumstances this will remain an integral part of the coupler and should not be removed. However, should the adaptor and coupler become separated or unscrewed, then the adaptor must be reassembled into the coupler and re-tightened. The 1/4" BSP adaptor must never be installed into the tensioner body before the coupler and seals are attached. Follow the procedure below if the adaptor has separated from the coupler.

- a. Clean the coupler thread and adaptor, removing all traces of debris.
- b. Coat the end of the adaptor which is to be screwed into the coupler (i.e. the end with the spigot and the female hexagon), with 'Loctite 270' and screw into the coupler until it is finger tight.
- c. Remove surplus 'Loctite'.
- d. Leave the assembly for a minimum of 30 minutes curing time before proceeding with assembly into the GT tensioner body.

Remove and discard the bonded seal.

Clean any dirt and debris from the tensioner body counterbore and the coupler spigot face.

Insert a new bonded seal into the counterbore.

Lubricate the thread on the adaptor with Omega 95 (or similar lubricant with a coefficient of friction = 0.12), and tighten to a torque of 45 lbf.ft [61 Nm]. Ensure that the bonded seal does not become nipped or dislodged during tightening.

**IMPORTANT:** Care must be taken not to over tighten the adaptors into the tensioner and to use the hexagon on the adaptor to pull it in rather than the hexagon on the male quick disconnect coupler which could induce bending, leading to failure.

## 9.0 STORAGE

Store tools fully retracted.

The finish will protect the tools from rust etc. but for added protection a light coating of oil or rust inhibitor should be applied to all plated surfaces.

Cover the internal threads on the inside of the puller bar and reaction nuts with a rust inhibitor.

Store tools upright.

Keep dust caps on the oil inlet couplers.

### Hydraulic Hose(s)

Wipe all hoses clean and apply a light coating of oil or suitable rust inhibitor to all couplers and tee blocks.

Always keep dust caps fitted to couplers.

### Pump Unit

Always store the pump upright.

Apply a light oil coating or suitable rust inhibitor to all exposed unplated metal items.

Leave the oil return to tank valve in the open position.

Always keep dust caps on inlet and outlet hydraulic fittings.

## 10.0 TECHNICAL DATA

### 10.1 GT Series Tensioner Specifications

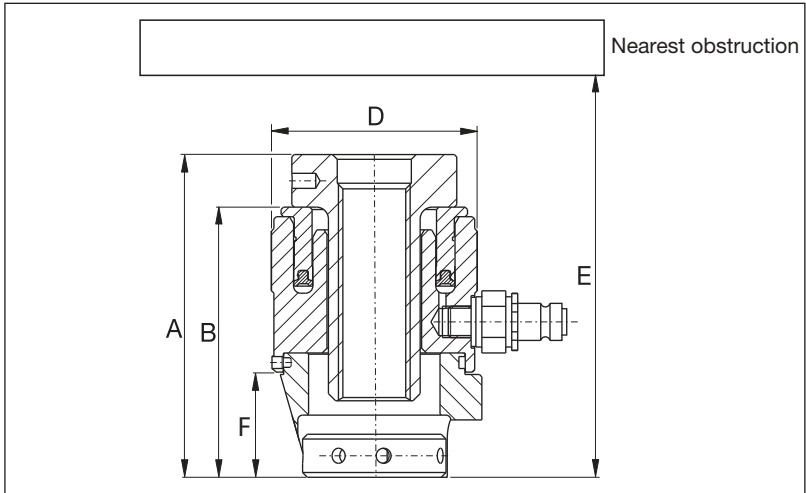

FIGURE 24A

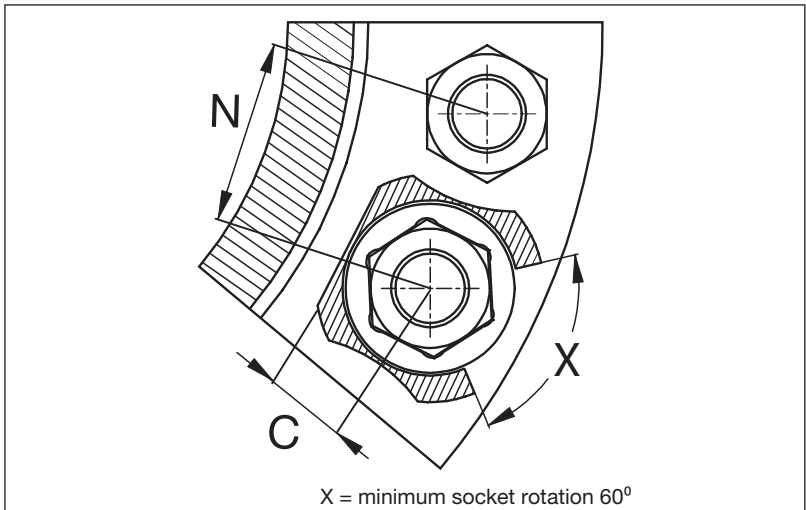

FIGURE 24B

## 10.2 GT Series Tensioner Specifications Metric Table

(see Fig 24 for locations of dimensions A, B, C, D, E, F, and N)

Load Cell Reference	Load Cell Weight (kg)	Model Number	Thread Size	Technical Data		Dimensions (mm)							Adaptor Kit Weight (kg)
				Cylinder Effective Area (mm <sup>2</sup> )	Load Capacity (kN)	A	B	C	D	E (min)	F	N (min)	
GT1-LCB	3.0	GT1PM-NRS01620	M16 x 2	1495.4	224.3	135	113	27	86	243	44	57	1.6
	3.0	GT1PM-NRS01825	M18 x 2.5	1495.4	224.3	135	113	27	86	243	44	58	1.5
	3.0	GT1PM-NRS02025	M20 x 2.5	1495.4	224.3	135	113	27	86	243	44	59	1.4
	3.0	GT1PM-NRS02430	M24 x 3	1495.4	224.3	135	113	27	86	243	44	61	1.3
	3.0	GT1PM-NRS02730	M27 x 3	1495.4	224.3	135	113	27	86	243	44	64	1.2
	3.0	GT1PM-NRS03035	M30 x 3.5	1495.4	224.3	135	113	27	86	243	44	66	1.0
	3.0	GT1P-NRS0625U11	¾"-11un	1495.4	224.3	135	113	27	86	243	44	57	1.6
	3.0	GT1P-NRS0750U10	¾"-10un	1495.4	224.3	135	113	27	86	243	44	59	1.4
	3.0	GT1P-NRS0875U09	7/8"-9un	1495.4	224.3	135	113	27	86	243	44	62	1.3
	3.0	GT1P-NRS1000U08	1"-8un	1495.4	224.3	135	113	27	86	243	44	64	1.2
GT2-LCB	3.0	GT1P-NRS1125U08	1 1/8"-8un	1495.4	224.3	135	113	27	86	243	44	66	1.0
	4.1	GT2PM-NRS03035	M30 x 3.5	2677.2	401.5	136	111	35	107	226	41	75	2.6
	4.1	GT2PM-NRS03335	M33 x 3.5	2677.2	401.5	136	111	35	107	226	41	76	2.4
	4.1	GT2PM-NRS03640	M36 x 4	2677.2	401.5	136	111	35	107	226	41	79	2.2
	4.1	GT2PM-NRS03940	M39 x 4	2677.2	401.5	136	111	35	107	226	41	82	1.9
	4.1	GT2P-NRS1125U08	1 1/8"-8un	2677.2	401.5	136	111	35	107	226	41	74	2.6
	4.1	GT2P-NRS1250U08	1 1/4"-8un	2677.2	401.5	136	111	35	107	226	41	76	2.4
	4.1	GT2P-NRS1375U08	1 3/8"-8un	2677.2	401.5	136	111	35	107	226	41	79	2.2
	4.1	GT2P-NRS1500U08	1 1/2"-8un	2677.2	401.5	136	111	35	107	226	41	82	2.0
	Maximum Stroke = 10 mm												
Maximum Pressure = 21,750 psi [1500 bar]													

Load Cell Reference	Load Cell Weight (kg)	Model Number	Thread Size	Technical Data		Dimensions (mm)						Adaptor Kit Weight (kg)	
				Cylinder Effective Area (mm <sup>2</sup> )	Load Capacity (kN)	A	B	C	D	E (min)	F		N (min)
GT3-LCB	7.0	GT3PM-NRS03940	M39 x 4	5127.1	768.9	160	126	46	138	256	56	96	5.7
	7.0	GT3PM-NRS04245	M42 x 4.5	5127.1	768.9	160	126	46	138	256	56	98	5.4
	7.0	GT3PM-NRS04545	M45 x 4.5	5127.1	768.9	160	126	46	138	256	56	101	5.0
	7.0	GT3PM-NRS04850	M48 x 5	5127.1	768.9	160	126	46	138	256	56	104	4.7
	7.0	GT3PM-NRS05250	M52 x 5	5127.1	768.9	160	126	46	138	256	56	107	4.2
	7.0	GT3P-NRS1500U08	1½"-8un	5127.1	768.9	160	126	46	138	256	56	95	5.7
	7.0	GT3P-NRS1625U08	1¾"-8un	5127.1	768.9	160	126	46	138	256	56	98	5.3
	7.0	GT3P-NRS1750U08	1¾"-8un	5127.1	768.9	160	126	46	138	256	56	101	5.0
	7.0	GT3P-NRS1875U08	1¾"-8un	5127.1	768.9	160	126	46	138	256	56	104	4.6
	7.0	GT3P-NRS2000U08	2"-8un	5127.1	768.9	160	126	46	138	256	56	106	4.2
GT4-LCB	12.2	GT4PM-NRS05250	M52 x 5	9782.1	1466.9	180	141	62	174	281	71	121	10.7
	12.2	GT4PM-NRS05655	M56 x 5.5	9782.1	1466.9	180	141	62	174	281	71	124	10.1
	12.2	GT4PM-NRS06055	M60 x 5.5	9782.1	1466.9	180	141	62	174	281	71	127	9.4
	12.2	GT4PM-NRS06460	M64 x 6	9782.1	1466.9	180	141	62	174	281	71	129	8.8
	12.2	GT4PM-NRS06860	M68 x 6	9782.1	1466.9	180	141	62	174	281	71	132	8.1
	12.2	GT4P-NRS2000U08	2"-8un	9782.1	1466.9	180	141	62	174	281	71	120	10.7
	12.2	GT4P-NRS2250U08	2¼"-8un	9782.1	1466.9	180	141	62	174	281	71	126	9.7
	12.2	GT4P-NRS2500U08	2½"-8un	9782.1	1466.9	180	141	62	174	281	71	132	8.5
	Maximum Stroke = 10 mm												
	Maximum Pressure = 21,750 psi [1500 bar]												

Load Cell Reference	Load Cell Weight (kg)	Model Number	Thread Size	Technical Data		Dimensions (mm)							Adaptor Kit Weight (kg)
				Cylinder Effective Area (mm <sup>2</sup> )	Load Capacity (kN)	A	B	C	D	E (min)	F	N (min)	
GT5-LCB	18.7	GT5PM1-NRS06860	M68 x 6	15079.7	2261.4	202	157	78	210	302	86	148	17.3
	18.7	GT5PM1-NRS07260	M72 x 6	15079.7	2261.4	202	157	78	210	302	86	149	16.4
	18.7	GT5PM1-NRS07660	M76 x 6	15079.7	2261.4	202	157	78	210	302	86	152	15.5
	18.7	GT5PM1-NRS08060	M80 x 6	15079.7	2261.4	202	157	78	210	302	86	155	14.6
	18.7	GT5P-NRS2500U08	2½"-8un	15079.7	2261.4	202	157	78	210	302	86	148	17.8
	18.7	GT5P-NRS2750U08	2¾"-8un	15079.7	2261.4	202	157	78	210	302	86	153	16.3
	18.7	GT5P-NRS3000U08	3"-8un	15079.7	2261.4	202	157	78	210	302	86	158	14.8
	18.7	GT5P-NRS3250U08	3¼"-8un	15079.7	2261.4	202	157	78	210	302	86	161	13.1
	27.8	GT6PM1-NRS08060	M80 x 6	18972.1	2845.1	219	173	82	240	323	95	167	22.3
GT6-LCB	27.8	GT6PM1-NRS08560	M85 x 6	18972.1	2845.1	219	173	82	240	323	95	170	21.0
	27.8	GT6PM1-NRS09060	M90 x 6	18972.1	2845.1	219	173	82	240	323	95	175	19.4
	27.8	GT6PM1-NRS09560	M95 x 6	18972.1	2845.1	219	173	82	240	323	95	179	18.0
	27.8	GT6P-NRS3250U08	3¼"-8un	18972.1	2845.1	219	173	82	240	323	95	173	20.7
	27.8	GT6P-NRS3500U08	3½"-8un	18972.1	2845.1	219	173	82	240	323	95	181	18.8
	27.8	GT6P-NRS3750U08	3¾"-8un	18972.1	2845.1	219	173	82	240	323	95	188	16.8
	38.2	GT7P-MNRS10060	M100x 6	26389.4	3958.4	243	182	89	277	332	110	196	28.5
	38.2	GT7P-MNRS10560	M105x 6	26389.4	3958.4	243	182	89	277	332	110	199	27.3
	38.2	GT7P-NRS4000U08	4"-8un	26389.4	3958.4	243	182	89	277	332	110	204	27.3
Maximum Stroke = 10 mm													
Maximum Pressure = 21,750 psi [1500 bar]													



### 10.3 GT Series Tensioner Specifications Imperial Table

(see Fig 24 for locations of dimensions A, B, C, D, E, F, and N)

Load Cell Reference	Load Cell Weight (lbs)	Model Number	Thread Size	Technical Data		Dimensions (in)							Adaptor Kit Weight (lbs)
				Cylinder Effective Area (in <sup>2</sup> )	Load Capacity (ton)	A	B	C	D	E (min)	F	N (min)	
GT1-LCB	6.6	GT1PM-NRS01620	M16 x 2	2.32	22.5	5.3	4.4	1.1	3.4	9.6	1.7	2.2	3.5
	6.6	GT1PM-NRS01825	M18 x 2.5	2.32	22.5	5.3	4.4	1.1	3.4	9.6	1.7	2.3	3.3
	6.6	GT1PM-NRS02025	M20 x 2.5	2.32	22.5	5.3	4.4	1.1	3.4	9.6	1.7	2.3	3.1
	6.6	GT1PM-NRS02430	M24 x 3	2.32	22.5	5.3	4.4	1.1	3.4	9.6	1.7	2.4	2.9
	6.6	GT1PM-NRS02730	M27 x 3	2.32	22.5	5.3	4.4	1.1	3.4	9.6	1.7	2.5	2.6
	6.6	GT1PM-NRS03035	M30 x 3.5	2.32	22.5	5.3	4.4	1.1	3.4	9.6	1.7	2.6	2.2
	6.6	GT1P-NRS0625U11	5/8"-11un	2.32	22.5	5.3	4.4	1.1	3.4	9.6	1.7	2.2	3.5
	6.6	GT1P-NRS0750U10	3/4"-10un	2.32	22.5	5.3	4.4	1.1	3.4	9.6	1.7	2.3	3.1
	6.6	GT1P-NRS0875U09	7/8"-9un	2.32	22.5	5.3	4.4	1.1	3.4	9.6	1.7	2.4	2.9
	6.6	GT1P-NRS1000U08	1"-8un	2.32	22.5	5.3	4.4	1.1	3.4	9.6	1.7	2.5	2.6
	6.6	GT1P-NRS1125U08	1 1/8"-8un	2.32	22.5	5.3	4.4	1.1	3.4	9.6	1.7	2.6	2.2
	GT2-LCB	9.0	GT2PM-NRS03035	M30 x 3.5	4.15	40.3	5.4	4.4	1.4	4.2	8.9	1.6	2.9
9.0		GT2PM-NRS03335	M33 x 3.5	4.15	40.3	5.4	4.4	1.4	4.2	8.9	1.6	3.0	5.3
9.0		GT2PM-NRS03640	M36 x 4	4.15	40.3	5.4	4.4	1.4	4.2	8.9	1.6	3.1	4.9
9.0		GT2PM-NRS03940	M39 x 4	4.15	40.3	5.4	4.4	1.4	4.2	8.9	1.6	3.2	4.2
9.0		GT2P-NRS1125U08	1 1/8"-8un	4.15	40.3	5.4	4.4	1.4	4.2	8.9	1.6	2.9	5.7
9.0		GT2P-NRS1250U08	1 1/4"-8un	4.15	40.3	5.4	4.4	1.4	4.2	8.9	1.6	3.0	5.3
9.0		GT2P-NRS1375U08	1 3/8"-8un	4.15	40.3	5.4	4.4	1.4	4.2	8.9	1.6	3.1	4.9
9.0		GT2P-NRS1500U08	1 1/2"-8un	4.15	40.3	5.4	4.4	1.4	4.2	8.9	1.6	3.2	4.4
Maximum Stroke = 0.39in													
Maximum Pressure = 21,750 psi [1500 bar]													

Load Cell Reference	Load Cell Weight (lbs)	Model Number	Thread Size	Technical Data		Dimensions (in)						Adaptor Kit Weight (lbs)	
				Cylinder Effective Area (in <sup>2</sup> )	Load Capacity (ton)	A	B	C	D	E (min)	F		N (min)
GT3-LCB	15.4	GT3PM-NRS03940	M39 x 4	7.95	77.2	6.3	5.0	1.8	5.4	10.1	2.2	3.8	12.6
	15.4	GT3PM-NRS04245	M42 x 4.5	7.95	77.2	6.3	5.0	1.8	5.4	10.1	2.2	3.9	11.9
	15.4	GT3PM-NRS04545	M45 x 4.5	7.95	77.2	6.3	5.0	1.8	5.4	10.1	2.2	4.0	11.0
	15.4	GT3PM-NRS04850	M48 x 5	7.95	77.2	6.3	5.0	1.8	5.4	10.1	2.2	4.1	10.4
	15.4	GT3PM-NRS05250	M52 x 5	7.95	77.2	6.3	5.0	1.8	5.4	10.1	2.2	4.2	9.3
	15.4	GT3P-NRS1500U08	1½"-8un	7.95	77.2	6.3	5.0	1.8	5.4	10.1	2.2	3.7	12.6
	15.4	GT3P-NRS1625U08	1¾"-8un	7.95	77.2	6.3	5.0	1.8	5.4	10.1	2.2	3.8	11.7
	15.4	GT3P-NRS1750U08	1¾"-8un	7.95	77.2	6.3	5.0	1.8	5.4	10.1	2.2	4.0	11.0
	15.4	GT3P-NRS1875U08	1¾"-8un	7.95	77.2	6.3	5.0	1.8	5.4	10.1	2.2	4.1	10.1
	15.4	GT3P-NRS2000U08	2"-8un	7.95	77.2	6.3	5.0	1.8	5.4	10.1	2.2	4.2	9.3
	26.9	GT4PM-NRS05250	M52 x 5	15.17	147.2	7.1	5.6	2.4	6.9	11.1	2.8	4.8	23.6
	26.9	GT4PM-NRS05655	M56 x 5.5	15.17	147.2	7.1	5.6	2.4	6.9	11.1	2.8	4.9	22.3
26.9	GT4PM-NRS06055	M60 x 5.5	15.17	147.2	7.1	5.6	2.4	6.9	11.1	2.8	5.0	20.7	
26.9	GT4PM-NRS06460	M64 x 6	15.17	147.2	7.1	5.6	2.4	6.9	11.1	2.8	5.1	19.4	
26.9	GT4PM-NRS06860	M68 x 6	15.17	147.2	7.1	5.6	2.4	6.9	11.1	2.8	5.2	17.9	
26.9	GT4P-NRS2000U08	2"-8un	15.17	147.2	7.1	5.6	2.4	6.9	11.1	2.8	4.7	23.6	
26.9	GT4P-NRS2250U08	2¼"-8un	15.17	147.2	7.1	5.6	2.4	6.9	11.1	2.8	4.9	21.4	
26.9	GT4P-NRS2500U08	2½"-8un	15.17	147.2	7.1	5.6	2.4	6.9	11.1	2.8	5.2	18.7	
Maximum Stroke = 0.39in													
Maximum Pressure = 21,750 psi [1500 bar]													

Load Cell Reference	Load Cell Weight (lbs)	Model Number	Thread Size	Technical Data		Dimensions (in)						Adaptor Kit Weight (lbs)	
				Cylinder Effective Area (in <sup>2</sup> )	Load Capacity (ton)	A	B	C	D	E (min)	F		N (min)
GT5-LCB	38.3	GT5PM-NRS06860	M68 x 6	23.37	227.0	8.0	6.2	3.1	8.3	11.9	3.4	5.8	38.1
	38.3	GT5PM-NRS07260	M72 x 6	23.37	227.0	8.0	6.2	3.1	8.3	11.9	3.4	5.9	36.2
	38.3	GT5PM-NRS07660	M76 x 6	23.37	227.0	8.0	6.2	3.1	8.3	11.9	3.4	6.0	34.2
	38.3	GT5PM-NRS08060	M80 x 6	23.37	227.0	8.0	6.2	3.1	8.3	11.9	3.4	6.1	32.2
	38.3	GT5P-NRS2500U08	2½"-8un	23.37	227.0	8.0	6.2	3.1	8.3	11.9	3.4	5.8	39.2
	38.3	GT5P-NRS2750U08	2¾"-8un	23.37	227.0	8.0	6.2	3.1	8.3	11.9	3.4	6.0	35.9
	38.3	GT5P-NRS3000U08	3"-8un	23.37	227.0	8.0	6.2	3.1	8.3	11.9	3.4	6.2	32.6
	38.3	GT5P-NRS3250U08	3¼"-8un	23.37	227.0	8.0	6.2	3.1	8.3	11.9	3.4	6.3	28.9
	61.3	GT6PM-NRS08060	M80 x 6	29.41	285.5	8.6	6.8	3.2	9.4	12.7	3.7	6.6	49.2
	61.3	GT6PM-NRS08560	M85 x 6	29.41	285.5	8.6	6.8	3.2	9.4	12.7	3.7	6.7	46.3
GT6-LCB	61.3	GT6PM-NRS09060	M90 x 6	29.41	285.5	8.6	6.8	3.2	9.4	12.7	3.7	6.9	42.8
	61.3	GT6PM-NRS09560	M95 x 6	29.41	285.5	8.6	6.8	3.2	9.4	12.7	3.7	7.0	39.7
	61.3	GT6P-NRS3250U08	3¼"-8un	29.41	285.5	8.6	6.8	3.2	9.4	12.7	3.7	6.8	45.6
	61.3	GT6P-NRS3500U08	3½"-8un	29.41	285.5	8.6	6.8	3.2	9.4	12.7	3.7	7.1	41.4
	61.3	GT6P-NRS3750U08	3¾"-8un	29.41	285.5	8.6	6.8	3.2	9.4	12.7	3.7	7.4	37.0
	84.2	GT7P-MNRS10060	M100x 6	40.90	397.3	9.6	7.2	3.5	10.9	13.1	4.3	7.7	62.8
GT7-LCB	84.2	GT7P-MNRS10560	M105x 6	40.90	397.3	9.6	7.2	3.5	10.9	13.1	4.3	7.8	60.2
	84.2	GT7P-NRS4000U08	4"- 8un	40.90	397.3	9.6	7.2	3.5	10.9	13.1	4.3	8.0	60.2
Maximum Stroke = 0.39in													
Maximum Pressure = 21,750 psi [1500 bar]													

## NOTES

---

---

---

---

---

---

---

---

---

---

---

---

---

---

---

---

---

---

---

---

---

---

---

---

---

---

---

## NOTES

---

---

---

---

---

---

---

---

---

---

---

---

---

---

---

---

---

---

---

---

---

---

---

---

---

**ENERPAC** 

**TOOLS. SERVICES. SOLUTIONS.**

<http://www.enerpac.com>