



## HL Tensioners

Hydratight's HL Tensioners provide a simple, safe, accurate and time saving method for tightening topside bolts and studs, maximising economy and versatility by utilising common hydraulic heads with interchangeable bridges, sockets and pullers.

Common hydraulic heads of the HT Tensioners enable the maximum number of bolt diameters to be covered with the minimum number of tools. Color coding of the hydraulic heads ensures easy identification of the tools.

- Maximum working pressure 1034 Bar (15,000 psi)
- All tools have 15mm (0.59") stroke except HT02 stroke = 6mm (0.24") and HT01 stroke = 8mm (0.31")
- Eccentric shaped tool applies to HT02
- Weight includes head, bridge, socket & puller
- Alternative size adaptor kits can be supplied on request

dimension G is measured across tool centerline

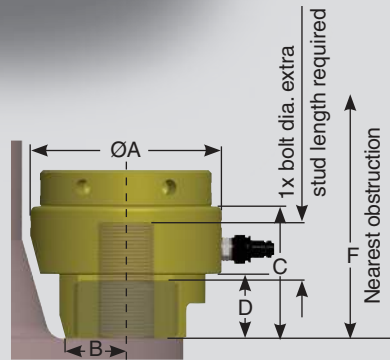
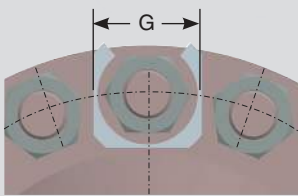

Tool Ref	Bolt Dia.		Tool Hyd Area		Max Load		Weight	Unit of Measure	A	B	C	D	F	G
	in	mm	in <sup>2</sup>	mm <sup>2</sup>	tonf	lbf								
HT02 Maroon	-	M16	in <sup>2</sup> mm <sup>2</sup>	2.10 1357	tonf lbf kN	14.09 31554 140.3	4.50 lb	Std - in	2.9	0.93	3.03	0.98	4.76	2.17
							2.04 kg	Metric - mm	73.5	23.5	77	25	121	55
	3/4"	M18					4.34 lb	Std - in	2.9	0.93	3.03	0.98	4.72	2.17
							1.97 kg	Metric - mm	73.5	23.5	77	25	120	55
	-	M20					4.23 lb	Std - in	2.9	1.04	3.03	0.98	4.76	2.4
HT01 Dk Green	1-1/8"	M27	in <sup>2</sup> mm <sup>2</sup>	3.53 2278	tonf lbf kN	23.64 52956 235.5	1.92 kg	Metric - mm	73.5	26.5	77	25	121	61
							4.23 lb	Std - in	2.9	1.04	3.15	1.1	4.98	2.4
							1.92 kg	Metric - mm	73.5	26.5	80	28	126	61
							6.88 lb	Std - in	3.4	1.16	3.66	1.34	5.78	2.52
							3.12 kg	Metric - mm	86	29.5	93	34	147	64
HL01 Dk Blue	1-1/4"	M33	in <sup>2</sup> mm <sup>2</sup>	5.40 3485	tonf lbf kN	36.17 81022 360.3	6.77 lb	Std - in	3.4	1.26	3.78	1.46	6.03	2.83
							3.07 kg	Metric - mm	86	32.0	96	37	153	72
							11.8 lb	Std - in	4.2	1.42	3.78	1.42	6.57	3.11
							5.36 kg	Metric - mm	107.0	36.0	96	36	167	79
							11.5 lb	Std - in	4.2	1.42	3.78	1.42	6.69	3.11
HL02 Orange	1-3/8"	M36	in <sup>2</sup> mm <sup>2</sup>	6.63 4276	tonf lbf kN	44.39 99429 442.2	5.21 kg	Metric - mm	107.0	36.0	96	36	170	79
							11.3 lb	Std - in	4.2	1.54	3.9	1.54	6.93	3.23
							5.11 kg	Metric - mm	107.0	39.0	99	39	176	82
							14.1 lb	Std - in	4.6	1.42	3.78	1.42	6.77	3.11
							6.40 kg	Metric - mm	117.0	36.0	96	36	172	79
HL03 Black	1-1/2"	M39	in <sup>2</sup> mm <sup>2</sup>	9.16 5909	tonf lbf kN	61.34 137392 611.0	13.9 lb	Std - in	4.6	1.54	3.9	1.54	7.01	3.23
							6.31 kg	Metric - mm	117.0	39.0	99	39	178	82
							14.7 lb	Std - in	4.6	1.65	4.13	1.77	7.36	3.39
							6.68 kg	Metric - mm	117.0	42.0	105	45	187	86
							20.6 lb	Std - in	5.4	1.65	4.13	1.77	7.52	3.39
HL03 Black	1-5/8"	M42	in <sup>2</sup> mm <sup>2</sup>	9.16 5909	tonf lbf kN	61.34 137392 611.0	9.35 kg	Metric - mm	136.0	42.0	105	45	191	86
							20.6 lb	Std - in	5.4	1.77	4.21	1.85	7.72	3.94
							9.35 kg	Metric - mm	136.0	45.0	107	47	196	100
							20.7 lb	Std - in	5.4	1.93	4.33	1.97	7.95	3.94
							9.38 kg	Metric - mm	136.0	49.0	110	50	202	100

## HL Tensioners

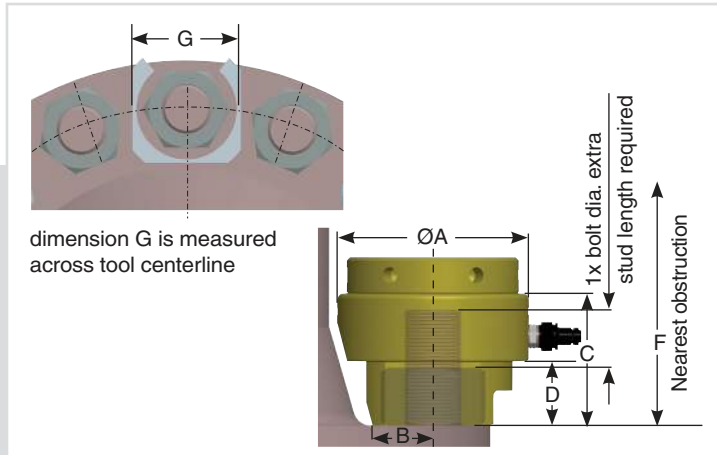

Tool Ref	Bolt Dia.		Tool Hyd Area		Max Load		Weight	Unit of Measure	A	B	C	D	F	G	
	in	mm	in <sup>2</sup>	mm <sup>2</sup>	tonf	lbf									
HL04 Red	1-5/8"	M42	in <sup>2</sup>	12.22	7881	tonf	81.81	25.9 lb	Std - in	5.9	1.77	4.21	1.85	7.8	3.94
		11.8 kg						Metric - mm	150.0	45.0	107	47	198	100	
	1-3/4"	M45						25.9 lb	Std - in	5.9	1.93	4.33	1.97	8.03	3.94
		11.8 kg						Metric - mm	150.0	49.0	110	50	204	100	
	1-7/8"	M48						26.4 lb	Std - in	5.9	2.01	4.45	2.09	8.27	4.41
		12.0 kg						Metric - mm	150.0	51.0	113	53	210	112	
	2"	M52						26.6 lb	Std - in	5.9	2.13	4.57	2.2	8.54	4.41
								12.1 kg	Metric - mm	150.0	54.0	116	56	217	112
HL05 Grey	1-7/8"	M48	in <sup>2</sup>	15.34	9894	tonf	102.7	32.9 lb	Std - in	6.7	2.01	4.45	2.09	8.27	4.41
		15.0 kg						Metric - mm	169.0	51.0	113	53	210	112	
	2"	M52						33.2 lb	Std - in	6.7	2.13	4.57	2.2	8.54	4.41
		15.1 kg						Metric - mm	169.0	54.0	116	56	217	112	
	2-1/4"	M56						34.4 lb	Std - in	6.7	2.32	4.8	2.44	8.94	5.04
								15.6 kg	Metric - mm	169.0	59.0	122	62	227	128
HL06 White	2-1/4"	M56	in <sup>2</sup>	19.75	12743	tonf	132.3	45.4 lb	Std - in	7.5	2.32	5	2.44	9.21	5.04
		20.6 kg						Metric - mm	190.0	59.0	127	62	234	128	
	-	M60						47.4 lb	Std - in	7.5	2.54	5.28	2.72	9.65	5.55
								21.5 kg	Metric - mm	190.0	64.5	134	69	245	141
	2-1/2"	M64						46.2 lb	Std - in	7.5	2.54	5.28	2.72	9.8	5.55
								21.0 kg	Metric - mm	190.0	64.5	134	69	249	141
HL07 Brown	2-1/2"	M64	in <sup>2</sup>	24.71	15944	tonf	165.5	57.7 lb	Std - in	8.2	2.54	5.31	2.72	10.08	5.55
		26.2 kg						Metric - mm	208.0	64.5	135	69	256	141	
	-	M68						59.7 lb	Std - in	8.2	2.8	5.55	2.95	10.47	6.3
								27.1 kg	Metric - mm	208.0	71.0	141	75	266	160
	2-3/4"	M72						58.1 lb	Std - in	8.2	2.8	5.55	2.95	10.63	6.3
								26.4 kg	Metric - mm	208.0	71.0	141	75	270	160
HL08 Lt Green	2-3/4"	M72	in <sup>2</sup>	28.40	18322	tonf	190.2	66.1 lb	Std - in	8.7	2.8	5.55	2.95	10.63	6.3
								30.0 kg	Metric - mm	222.0	71.0	141	75	270	160
	3"	M76						71.7 lb	Std - in	8.7	3.03	5.83	3.23	11.06	6.77
								32.5 kg	Metric - mm	222.0	77.0	148	82	281	172
HL85 Lt Blue	3"	M76	in <sup>2</sup>	33.76	21778	tonf	226.0	82.6 lb	Std - in	9.4	3.7	5.83	3.23	11.34	6.77
								37.5 kg	Metric - mm	239.0	94.0	148	82	288	172
	-	M80						81.7 lb	Std - in	9.4	3.43	6.1	3.5	11.77	7.87
								37.1 kg	Metric - mm	239.0	87.0	155	89	299	200
	3-1/4"	M85						79.8 lb	Std - in	9.4	3.43	6.1	3.5	11.97	7.87
								36.2 kg	Metric - mm	239.0	87.0	155	89	304	200
	3-1/2"	M90						78.4 lb	Std - in	9.4	3.66	6.38	3.78	12.44	7.48
								35.6 kg	Metric - mm	239.0	93.0	162	96	316	190
HL10 Gold	3-3/4"	M95	in <sup>2</sup>	40.53	26147	tonf	271.4	120 lb	Std - in	10.9	3.9	6.65	4.02	12.81	8.98
								54.4 kg	Metric - mm	276.0	99.0	169	102	326	228
	4"	M100						123 lb	Std - in	10.9	4.13	6.89	4.25	13.31	9.45
								55.7 kg	Metric - mm	276.0	105.0	175	108	338	240