



Torque and tension specialist

Instruction Sheet

PGT-Series Single Stage Tensioners

Contents

1.0	IMPORTANT RECEIVING INSTRUCTIONS	1
2.0	SAFETY	1
3.0	CONFORMANCE TO NATIONAL AND INTERNATIONAL STANDARDS.....	3
4.0	PRODUCT DESCRIPTION	3
5.0	ASSEMBLY	4
6.0	OPERATION.....	5
7.0	MAINTENANCE.....	8
8.0	STORAGE	15
9.0	TROUBLESHOOTING.....	16
10.0	TECHNICAL DATA.....	17

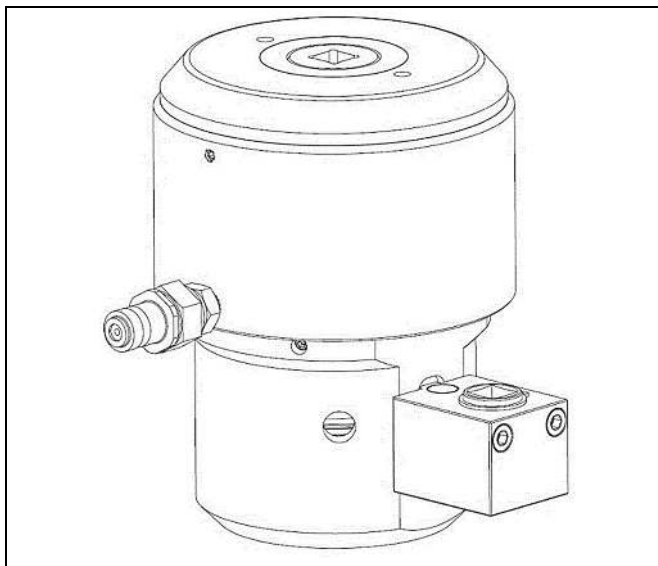
**1.0 IMPORTANT RECEIVING INSTRUCTIONS**

Visually inspect all components for shipping damage. Shipping damage is not covered by warranty. If shipping damage found, notify carrier at once. The carrier is responsible for all repair and replacement costs resulting from damage in shipment.

2.0 SAFETY**2.1 Introduction**

Read all introductions carefully. Follow all recommended safety precautions to avoid personal injury as well as damage to the product and / or damage to other property. Enerpac cannot be responsible for any damage or injury from unsafe use, lack of maintenance, or incorrect operation. Do not remove warning labels, tags, or decals. In the event of any questions or concerns arising, contact Enerpac or a local Enerpac distributor for clarification.

If you have never been trained on high-pressure hydraulic safety, consult your distributor or service centre for information about Enerpac Hydraulic Safety Courses.

This manual follows a system of safety alert symbols, signals, words, and safety messages to warn the user of specific hazards. Failure to comply with these warnings could result in death or serious personal injury, as well as damage to the equipment or other property.



The Safety Alert Symbol appears throughout this manual. It is used to alert you to potential physical injury hazards. Pay close attention to Safety Alert Symbols and obey all safety messages that follow this symbol to avoid the possibility of death or serious injury.

Safety Alert Symbols are used in conjunction with certain Signal Words that call attention to safety messages or property damage messages and designate a degree or level of hazard seriousness. The Signal Words used in this manual are WARNING, CAUTION, and NOTICE.



Indicates a hazardous situation that, if not avoided, **could** result in death or serious personal injury.



Indicates a hazardous situation that, if not avoided, **could** result in minor or moderate personal injury.



Indicates information considered important, but not hazard related (e.g. messages relation to property damage). Please note that Safety Alert Symbol will **not** be used with the signal word.

2.2 General Hydraulic Safety Precautions



Failure to observe and comply with the following precautions could result in death or serious personal injury. Property damage could also occur.

- Read and completely understand the safety precautions and instructions in this manual before operating the tensioners or preparing them for use. Always follow all safety precautions and instructions, including those that are contained within the procedures of this manual.
- When the system is under pressure **DO NOT STAND IN LINE** with the direction of force of the tensioners. Keep this area clear of personnel at all times when the system is under pressure. If the bolt should fail, serious personal injury or death could result if loose or broken parts become projectiles.
- Operating procedures will vary, depending on the system arrangement. Always read, follow and completely understand all manufacturers' instructions when operating pumps, valves and all other devices used with the tensioners. Follow all safety precautions contained in the manufacturer's manuals. Use only for intended purpose.
- Wear personal protective gear when operating hydraulic equipment. Always wear eye protection. Safety equipment such as dust mask, non-skid safety shoes, hard hats, gloves or hearing protection (used as appropriate) will reduce personal injuries.
- Ensure that the strengths of the bolts are known and that the recommended tensioning applied loads are well within the safe limits.
- Do not handle pressurized hoses. Escaping oil under pressure can penetrate the skin. If oil is injected under the skin, see a doctor immediately.
- Do not pressurize disconnected couplers.
- The system operating pressure must not exceed the pressure rating of the lowest rated component in the system.
- Install pressure gauge(s) in the system to monitor operating pressure. It is your window to see what is happening in the system.
- Never set a relief valve to a higher pressure than the maximum rated pressure of the pump and tensioner. If ratings are different, relief valve setting should not exceed the setting of the lowest rated component (pump or tensioner).
- Do not exceed equipment ratings. Never attempt to apply more load to a bolt than the maximum capacity of the tensioner. Overloading may cause equipment failure and possible personal injury.
- Do not drop heavy objects on hoses. A sharp impact may cause internal damage to hose wire strands.

Applying pressure to a damaged hose may cause it to rupture.

- Be sure setup is stable before applying load. Tensioners should be located on a firm and level surface capable of supporting the full load.
- Always perform a visual inspection of the tensioner before placing it into operation. If any problems are found, do not use the tensioner. Have the tensioner repaired and tested by an Enerpac Authorized Service Centre before it is returned to service.
- Never use a tensioner that is leaking oil. Do not use a tensioner that is damaged, altered or in need of repair.
- Allow only trained and experienced personnel to supervise and perform tensioning procedures.
- Always be certain that hydraulic pressure is fully relieved and that the load is fully removed from the tensioner(s) before disconnecting hydraulic hoses, loosening hydraulic fittings, or performing any tensioner disassembly or repair procedures.
- Ensure that the bolt protrusion is at least the amount stated in the applicable General Arrangement Drawing.
- Do not exceed the indicated maximum stroke of the tool.
- Never leave the system unattended when under pressure.



Failure to observe and comply with the following precautions could result in minor or moderate personal injury. Property damage could also occur.

- Be careful to avoid damaging hydraulic hoses. Avoid sharp bends and kinks when routing hydraulic hoses.
- Do not bend beyond the minimum bend radius specified by the hose manufacturer. Using a bent or kinked hose will cause severe back-pressure. Sharp bends and kinks will internally damage the hose, leading to premature hose failure.
- Do not lift hydraulic equipment by the hoses or couplers. Use the tensioner lifting eyes-bolts and appropriately rated lifting equipment, where appropriate.
- Keep hydraulic equipment away from flames and heat. Excessive heat will soften packings and seals, resulting in fluid leaks. Heat also weakens hose materials and packings.
- For optimum performance, do not expose hydraulic equipment to temperatures of 150 °F [65 °C] or higher.
- Immediately replace worn or damaged parts with genuine Enerpac parts. Enerpac parts are designed to fit properly and to withstand high loads. Non-Enerpac parts may break or cause the product to malfunction.
- Use hydraulic tensioners only in a coupled system. Never use a tensioner with uncoupled couplers.

NOTICE

- Hydraulic equipment must only be serviced by a qualified hydraulic technician. For repair service, contact the Enerpac Authorized Service Centre in your area.
- Rope off working area and place warning signs.
- To help ensure proper operation and best performance, use of Enerpac oil is strongly recommended.

2.3 Additional References

Consult the applicable industry and/or government standards in your country or region for additional safety precautions and work rules applicable to hydraulic tensioners, and other similar tensioning equipment.

In the USA, refer to the following publication:

- Code of Federal Regulations – Title 29 Occupational Safety and Health Standards (U.S. Government Publishing Office, 732 North Capitol Street, NW, Washington, DC 20401-0001. www.gpo.gov).

In the European Union, refer to the standards and directives listed in the product's EU Declaration of Conformity. A copy of this document is packed separately with the tensioner.

3.0 CONFORMANCE TO NATIONAL AND INTERNATIONAL STANDARDS



Enerpac declares that this product has been tested and conforms to applicable standards and is compatible to all CE Requirements. A copy of an EU Declaration of Conformity is enclosed with each shipment of this product.

4.0 PRODUCT DESCRIPTION

4.1 Introduction

NOTICE

The Enerpac PGT-Series Single Stage Tensioners are designed for the precision tensioning of bolted joints in an industrial environment. Due to the high degree of competency required to safely operate this type of device, the tensioners and ancillary equipment are intended to be used by trained professional operators only. The equipment is not intended to be used by untrained operators or in a non-industrial environment. The equipment is designed to be operated within an ambient temperature range of -10°C to +50°C and should not be used in a corrosive or explosive atmosphere.

WARNING

Modification to any part of the equipment outlined in this manual should not be attempted, nor any component part be replaced without first consulting Enerpac. Modifications may render the equipment dangerous. Component parts are each rated to suit the demands of the overall equipment design and replacement with similar items without provenance may lead to unexpected and dangerous accidental failures. Failure to observe these instructions and precautions could result in death or serious injury.

If any equipment abuse is evident, the warranty will be invalidated and Enerpac will not be made responsible for an injury due to misuse or failure to comply with the above safety precautions.

4.2 Pump Requirements

This bolt tensioning equipment has been designed to be used in conjunction with a hydraulic pump unit. Enerpac can offer a range of pump options to suit particular applications and thus operators should refer to the specific instruction manual for the pump to be used. The safety rationale used in the design of this tensioner has assumed a pump maximum working pressure appropriate for the tool and using hydraulic oil between ISO 22 and ISO 68, which are available as part of the Enerpac HF Series of hydraulic fluids. Enerpac HF oil is available at your local Enerpac Distributor or Authorized Service Centre.

Hydraulic connection is made using quick disconnect male & female couplings. In the event an alternative pump unit is used, additional safety measures such as pressure relief valves or bursting discs must be considered to ensure over-pressurisation cannot occur.

See pump manual for operating instructions.

4.3 PGT-Series Single Stage Tensioner Major Features and Components

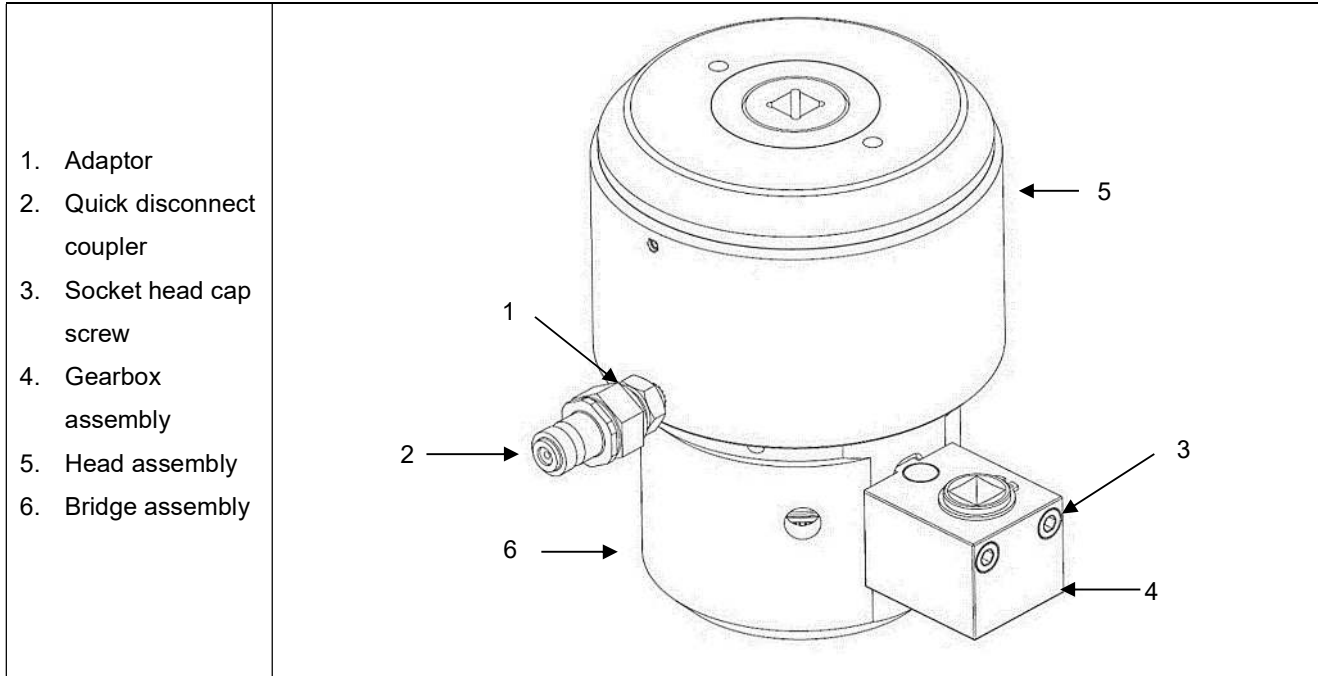

Fig. 1.1 Major features and components of PGT-Series Single Stage Tensioner

5.0 ASSEMBLY

5.1 Bolt Preparation

Simple bolt preparation will significantly reduce the risk of problems occurring during tensioner application and operation. Therefore, we would recommend that the following preparations and checks are adopted whenever possible.

To accommodate a PGT-Series Single Stage Tensioner, an extended portion of bolt is required above the nut. The recommended maximum and minimum protrusion is detailed in the applicable General Arrangement Drawing.

The tensioner must be able to be freely threaded onto all bolts over the length protruding through the flange faces. The puller bar must be free running on all bolts over the extended portion above the nut.

Protect the bolt protrusion using sleeves, adhesive tape, etc. This will protect the threads from knocks and damage during installation.

It is advisable that upon completion of the tensioning operation protector caps be fitted to the nut/thread protrusion. This will minimise corrosion and therefore assist in future disassembly.

5.2 Hose Connection

Ensure the pump hydraulic oil return valve is fully open.

Connect the hose from the pump to the male coupling of the first tensioner. If multiple tensioners will be used, attach a manifold to the tensioner male fitting, and connect the feed hose to the male coupling of the manifold. Attach a hose to the female coupler of the manifold on the first tensioner, and to the male coupler of the second tensioner. Follow this process for all subsequent tensioners.

When the hydraulic circuit is complete, no unconnected couplings should exist.

NOTICE

- Ensure that the hoses are free of obstructions and do not cross such that upon pressurisation, detrimental loads will be induced on the connectors and adaptors potentially leading to failure.
- Quick-disconnect couplings are susceptible to knocks and damage therefore, take care when handling the equipment. A damaged coupling may prove very difficult to connect.
- Ensure hose(s) have been filled with hydraulic oil and all air has been purged from the system in preparation for tensioning.

6.0 OPERATION

6.1 General

To achieve the correct final tension when using PGT-Series Single Stage Tensioning tools, each bolt must be tensioned as often as required until application of the calculated oil pressure results in no further bolt extension (i.e. until the nuts cannot be turned any further whilst the tools are at the calculated working pressure).

If during application of pressure the tools attain their maximum permissible stroke before the calculated working pressure is reached, then the nuts must be tightened down at this point and the tools retracted before the pressure is reapplied.

6.2 Tightening Procedure For Single Stage Tensioners

NOTICE There is a yellow coloured indicator groove marked around the top of the puller bar which indicates that the tensioner has reached its maximum stroke. If this line is observed, stop the pump and do not continue to pressurise the tool(s). It will be necessary to tighten the nut(s) down, and retract the tool(s) before continuing. (Fig. 2.1)

To tighten a bolt proceed as follows; refer also to the applicable General Arrangement Drawing as necessary.

Check that the bolts have been assembled correctly. Refer to the General Arrangement drawing for the required thread extension above the joint face.

Tighten all nuts down hand tight using a standard wrench. Excessive force is unnecessary as the tensioner will do the work. (Fig. 2.2)

Check that the hydraulic tensioner is fully retracted and the puller bar rotates freely within the tool. When the tool is fully retracted the end of the puller bar will be flush with the top of the tool. (Fig. 2.3)

CAUTION

- The contact area for the bridge must be flat and complete. If washers are used, they must not interfere with the location of the bridge.
- Do not use if the bridge is not sitting squarely on the flange surface i.e. the axis of the tool is not parallel to the axis of the bolt. Possible causes are due to the flange/tower weld obstructing the head assembly or the flange hub radius obstructing the bridge. Upon pressurisation the tensioner will have a tendency to self-align which may result in damage to the tensioner
- Do not use on applications that have insufficient bolt protrusion, as indicated on the applicable General Arrangement drawing

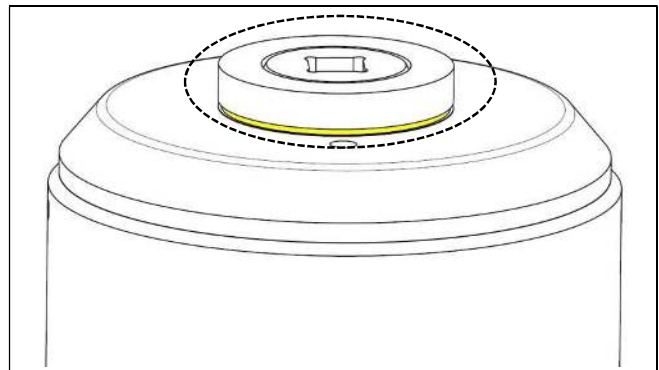

Fig. 2.1 Puller bar indicator groove

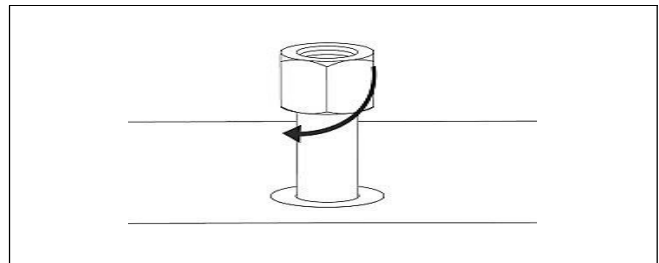

Fig. 2.2 Preparation of application

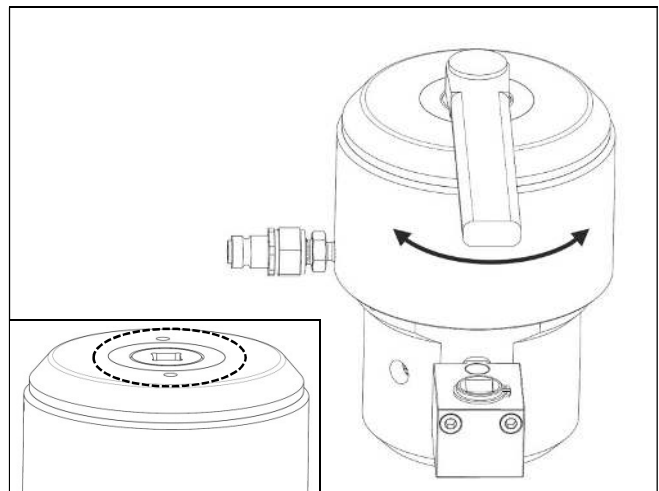

Fig. 2.3 Pre-installation checks of the tensioner

Holding the tool assembly firmly over the bolt, tighten the puller bar down using a ratchet wrench (1/2"/ 13mm or 3/8"/ 10mm male square) so that the base of the bridge mates with the joint face. Ensuring the bridge base is fully supported and seated squarely on the joint face. (Fig. 2.4)

NOTICE Ensure that the output of the wrench is limited to producing a maximum torque of 22.1 ft lb/ 30 Nm.

It is advised that the hydraulic fitting is offset to the gearbox to allow access to the gearbox-input drive. (Fig. 2.4)

Check that the socket is sitting down around the nut by utilising the viewing hole in the bridge.

NOTICE If necessary use a 1/2"/ 13mm or 3/8"/ 10mm square male square ratchet wrench to rotate the gearbox input drive clockwise to allow the socket to drop down around the nut. (Fig. 2.5)

Assemble any further tools as described above.

NOTICE If multiple tools are used; tools should be equally spaced and a sensible tightening sequence used. If in doubt consult Enerpac for advice.

Connect the hose from the pump to the male coupling of the first tensioner. If multiple tensioners will be used, attach a manifold to the tensioner male fitting, and connect the feed hose to the male coupling of the manifold. Attach a hose to the female coupler of the manifold on the first tensioner, and to the male coupler of the second tensioner. Follow this process for all subsequent tensioners. (Fig. 2.6)

Ensure there is no pressure in the hydraulic pump and connect the tensioner(s) to the pump using a hydraulic hose(s) as appropriate. Ensure that the couplings are securely connected using the male/ female coupling.

Operate the hydraulic pump to pressurise the tensioner(s). Observe the extension constantly during this operation using the coloured indicator groove marked on the puller bar. Do not exceed the maximum stroke on the applicable General Arrangement Drawing, and stop pressurisation as soon as this is observed.

When the desired operating pressure is reached, stop the pump and whilst holding the pressure constant tighten the nut down to the joint face by rotating the gearbox-input drive clockwise using a ratchet wrench (1/2" or 13mm male square/ 3/8" or 10mm square). (Fig. 2.7)

NOTICE Do not exceed the maximum working pressure of the tensioner, and ensure that the input torque applied to the gearbox is limited to a maximum value of 22.1 ft lb/ 30 Nm.

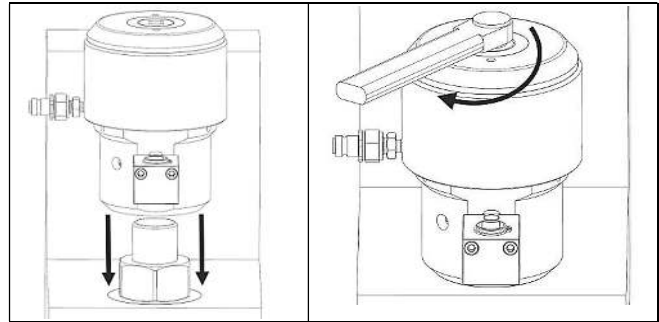

Fig. 2.4 Correct positioning of tensioner

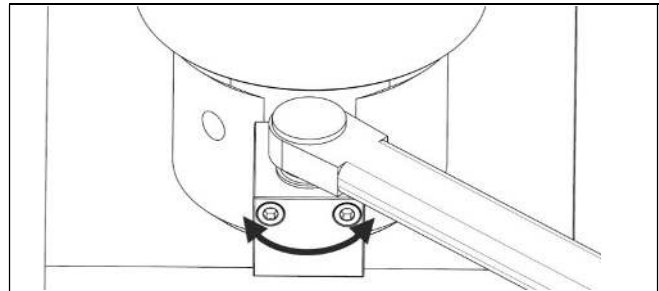

Fig. 2.5 Adjust gearbox socket

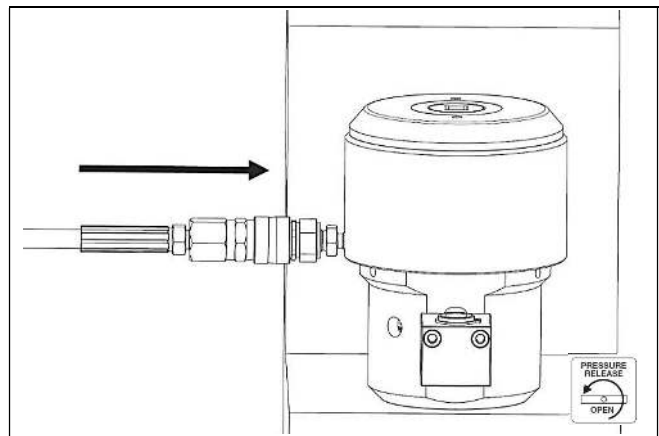

Fig. 2.6 Hose connection

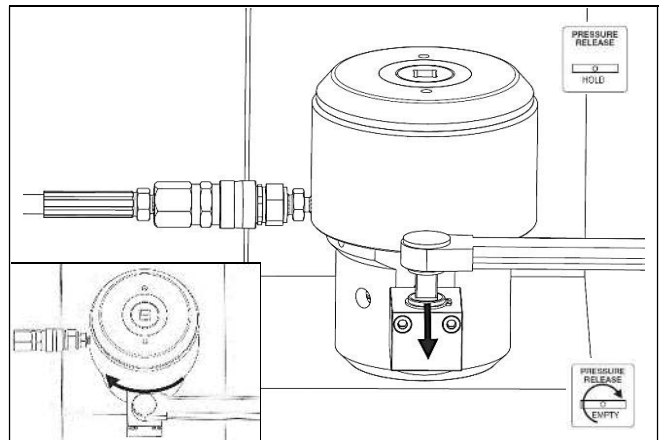

Fig. 2.7 Turn gearbox drive to tighten nut

Release the hydraulic pressure by slowly turning the return-to-tank valve on the pump unit. When the gauge on the pump unit shows zero pressure open the return-to-tank valve fully.

Allow the spring retraction mechanism to return the hydraulic head assembly to zero extension.

NOTICE The hydraulic hose(s) should always remain coupled to the tensioner(s) whilst retraction takes place, this allows the oil to flow back to the pump. Screw the puller bar further onto the bolt in order to retract the inserts fully. When fully retracted, the top surface of the puller bar should be flush or just below the top surface of the spring cap.

Disconnect the hydraulic hose(s), then unscrew and remove the tensioner from the bolt. (Fig. 2.8)

Reposition the tools over the next set of bolts to be tensioned and continue as above until all the bolts have been tensioned once. This will complete the first cycle. (Fig. 2.8)

Reposition the tensioner onto the first set of bolts to be tightened and repeat the tensioning.

Check that the nut is tight at the required operating pressure. If the drive gear can be turned by more than a 45° (15 degrees of nut rotation) (Fig. 2.9a), then another complete tensioning cycle must be performed. (Fig. 2.9b)

When the nut is tight on testing the bolt, the tensioning process is complete.

When all tools are fully retracted disconnect the hose(s) from the tensioner(s).

Unscrew the puller bar(s) from the bolt(s) and lift the tensioner(s) off the bolt(s).

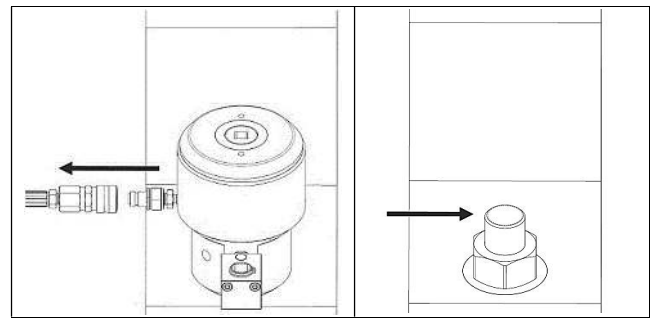

Fig. 2.8 Detach hose, move Tensioner to next bolt

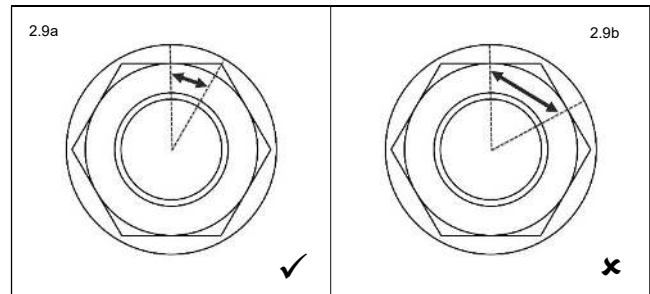

Fig. 2.9a Bolt tensioning complete
Fig. 2.9b Bolt tensioning incomplete

6.3 Detensioning Procedure

The detensioning procedure for PGT-Series Single Stage Tensioners is identical to the tightening procedure with the following important exceptions:

When screwing the tensioner onto the bolt, the puller bar must be screwed down until the base of the bridge mates with the joint face, the puller bar must then be turned back by 1/2 a turn. (Fig. 3.1)

NOTICE This procedure is to prevent the tensioner becoming locked on to the bolt. One half turn is usually sufficient, but if for any reason the tensioner is locked on to the bolt then retighten as per the tightening procedure and repeat but unscrew by 3/4 of a turn.

When the required pressure is reached the application nut must be unscrewed by approximately 1/2 a complete turn. Rotate the gearbox input drive anti-clockwise by one full turn to achieve this. (Fig. 3.2) The nut should turn freely without excessive torque being applied. If for any reason (principally corrosion or thread damage), the nut will not unscrew, **DO NOT** increase the pressure beyond the recommended maximum operating pressure. Once the nut has been lifted off the face of the application a further increase in pressure will not help.

7.0 MAINTENANCE

It is recommended that servicing be performed by an Enerpac Authorized Service Centre. All parts must be thoroughly inspected and replaced where necessary.

NOTICE All parts will have been manufactured, inspected and tested in accordance with Enerpac's stringent requirements. Product failures that result from the use of spare parts that are not genuine Enerpac spare parts will not be covered by warranty.

CAUTION The following instructions have been included primarily for the purpose of accessing the internal running surfaces of the tensioner which may require additional lubrication from time to time. Unless personnel have been specifically trained to service high pressure hydraulic tensioning equipment, it is strongly recommended that the tensioners be returned to an Enerpac Authorized Service Centre if seal replacement is required.

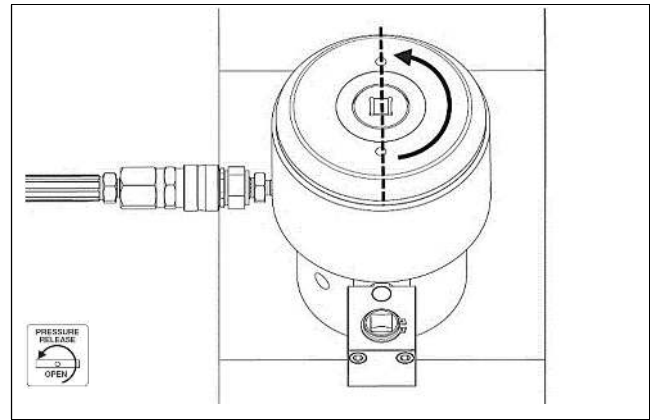

Fig. 3.1 Tighten puller bar back 3/4 of full turn

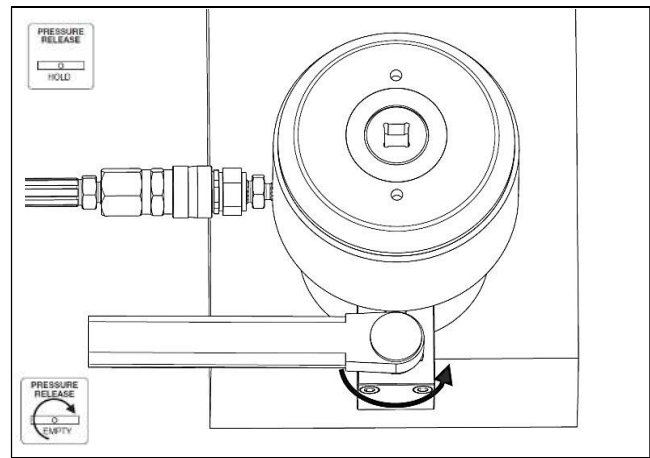

Fig. 3.2 Turn gearbox drive anti-clockwise

7.1 Dismantlement of the Hydraulic Head Assembly

To dismantle and re-assemble the hydraulic head assembly, proceed as follows. Refer also to the applicable General Arrangement Drawing as necessary.

Position the head assembly vertically in a soft jaw vice holding onto the outer body. Remove the hydraulic head assembly from the bridge assembly by unscrewing the set screws holding the two assemblies together. (Fig. 4.1)

Insert two tommy bars into the holes located on the spring cap and unscrew the spring cap anticlockwise, lifting it off the head assembly. (Fig. 4.2)

Remove the disc springs and spring insert, be sure to note the stacking arrangement of the disc springs as this will need to be maintained for re-assembly. (Fig. 4.3)

Re-position the head assembly in the soft jaw vice, this time holding onto the puller bar. Carefully slide the body, bearing ring and insert assembly off of the puller bar. Take care not to damage the internal surfaces on the external threads of the puller bar. (Fig. 4.4)

The tool is now dismantled to such an extent that all internal running surfaces will be accessible. Clean these surfaces as necessary.

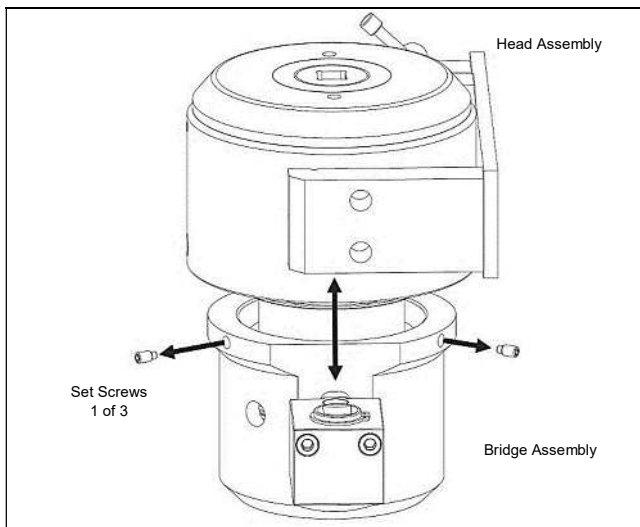

Fig. 4.1 Separation of head assembly and bridge assembly

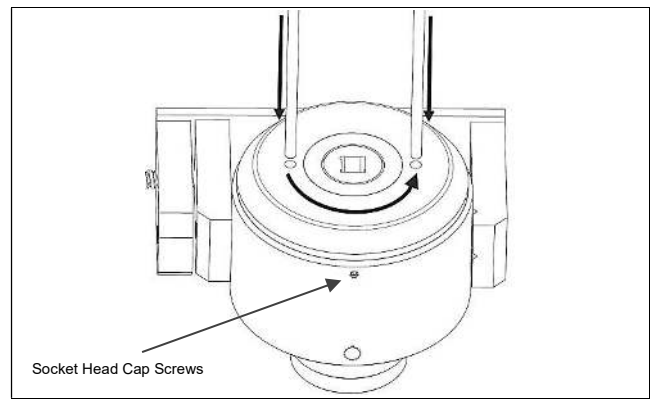

Fig. 4.2 Using tommy bars remove spring cap

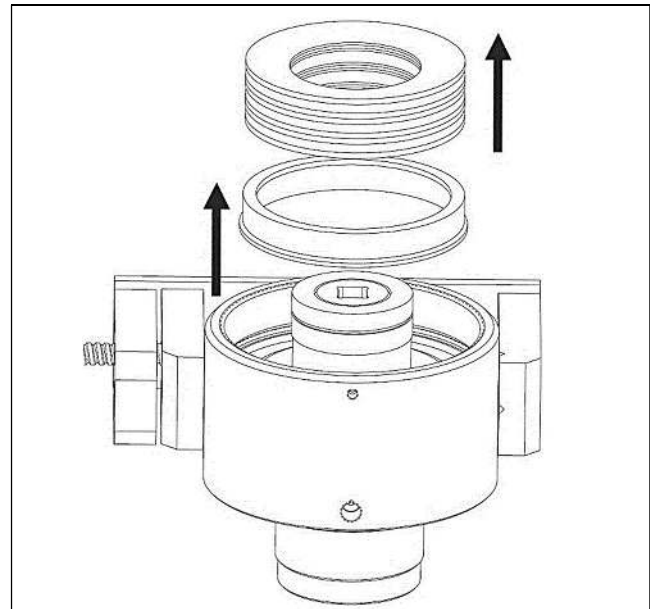

Fig. 4.3 Remove disc springs and spring insert

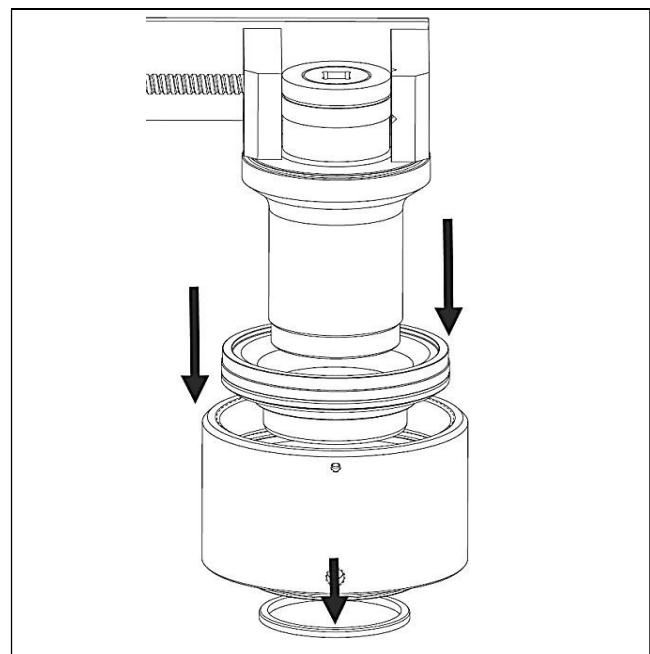

Fig. 4.4 Remove body, bearing ring, insert assembly

7.2 Re-assembly of the Hydraulic Head

Having dismantled the hydraulic head assembly, proceed as follows to re-assemble the hydraulic head:

Ensure that all the exposed internal faces are in good condition and free from dirt and other foreign particles.

Apply a medium coat of suitable grease (as recommended in Section 10.0) to these surfaces. Pay particular attention to the internal mating / running surfaces between the puller bar and inserts, those between the inserts and reaction nuts, and those between the upper reaction nut and spring insert.

Continue in reverse order of the dismantlement instructions bearing in mind the following additional notes:-

- When sliding the body and insert assemblies back onto the puller bar, take care not to damage any of the internal surfaces. (Fig. 4.5)
- Ensure that the disc spring stacking arrangement is maintained. (Fig. 4.6)
- Position head assembly in the soft jaw vice as necessary during assembly.

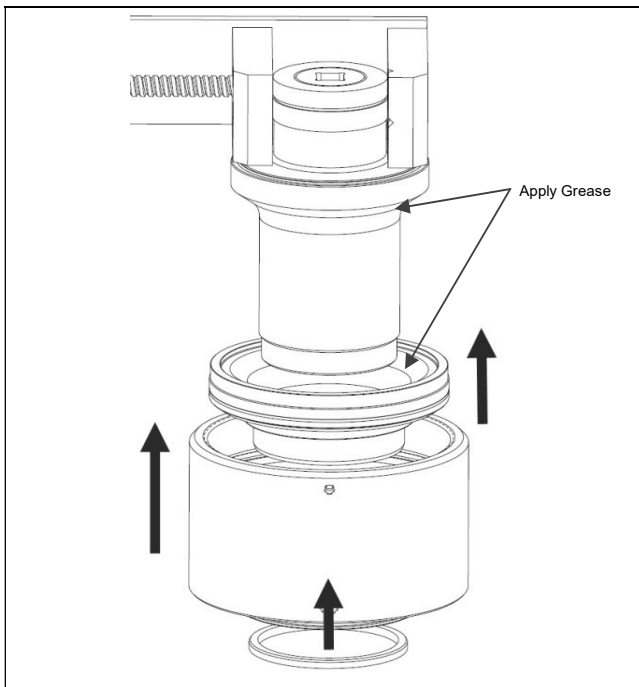

Fig. 4.5 Fit insert assembly, body, and bearing ring onto puller bar

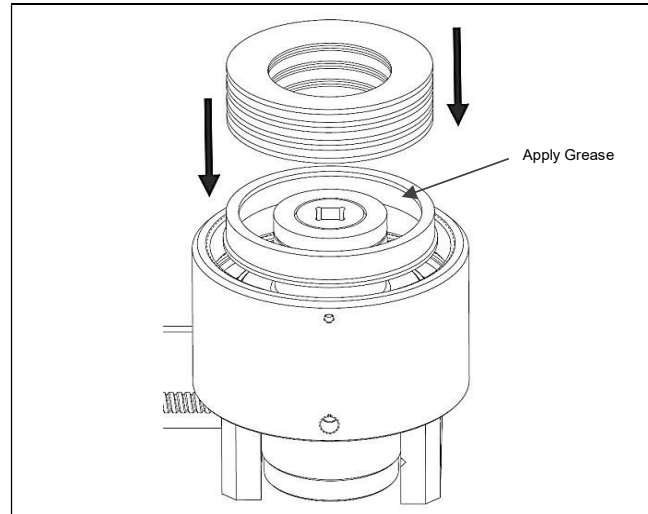

Fig. 4.6 Insert spring insert and disc springs, taking care they are stacked correctly

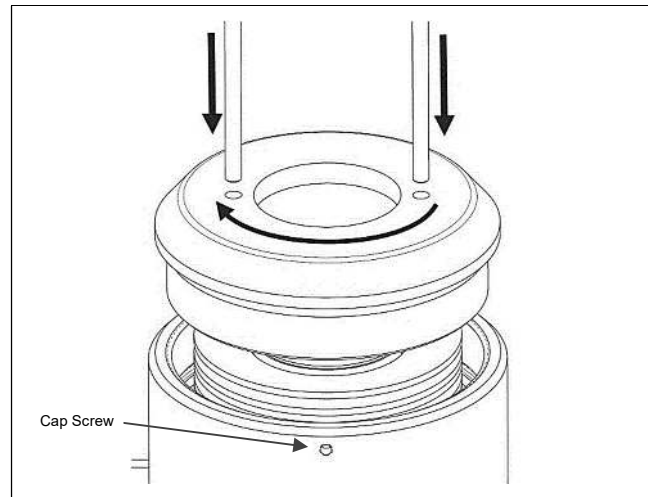

Fig. 4.7 Secure spring cap into place

CAUTION Under no circumstances should a damaged cap screw be re-used. If a tensioner is being re-furbished, **ALWAYS** check the cap screws for damage or fatigue and replace with new ones where required. Reusing damaged cap screws could result in tensioner failure during use, potentially causing the release of hydraulic fluid and endangering the operator and bystanders.

7.3 Additional Lubrication

Depending upon the conditions and orientation in which the tools are being used, it may be necessary from time to time to apply additional lubrication to the internal running surfaces of the tensioner. Particular attention should be paid to this point if the tensioner is being used in conjunction with an electric / pneumatic torque driver, as any damage caused due to the lack of lubrication has the potential to quickly escalate.

The main surfaces which are likely to require additional lubrication are those between the puller bar and the insert, those between the insert and spring insert. (Fig. 4.8) Follow the hydraulic head assembly dismantlement procedure to gain access to the relevant components and apply a medium coat of suitable grease (as recommended in Section 10.0) to all running surfaces mentioned above. Follow the assembly procedure to re-assemble the tool.

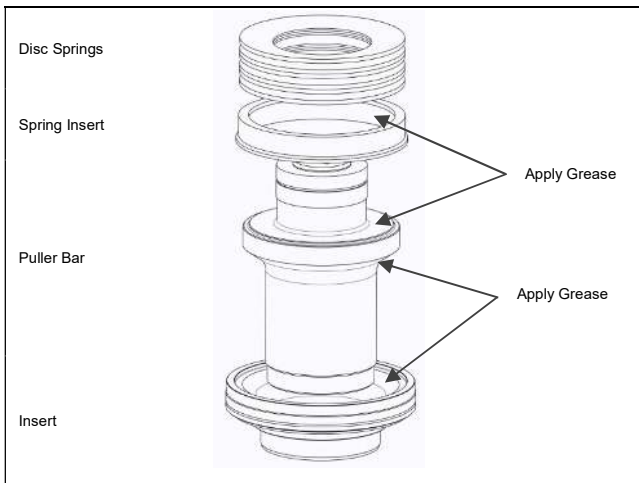

Fig. 4.8 Areas of additional lubrication

7.4 Replacing Hydraulic Seals

Precautions

The following precautions must be taken with the assembly of the hydraulic seals:

- Avoid sharp edges (cover thread areas)
- Remove all dust, dirt, swarf, and foreign particles.
- Do not use sharp edged tools.
- Lubricate all components before assembly.

Hydraulic seal replacement must only be carried out should the seals become damaged. The seals should not be removed during routine maintenance.

Hydraulic Seals - Component Parts

The seal kit comprises an inner and outer seal, both of which are comprised of two parts; the main seal is a red polyurethane elastomer and is very flexible and an anti-extrusion ring which is manufactured from a harder material. Care must be taken to ensure that the anti-extrusion ring is not damaged or kinked before or during assembly. (Fig. 4.9/ 4.10)

NOTICE Figures 4.8 and 4.9 are provided for guidance only. Parts shown may appear slightly different in appearance than the actual parts used on your tensioner.

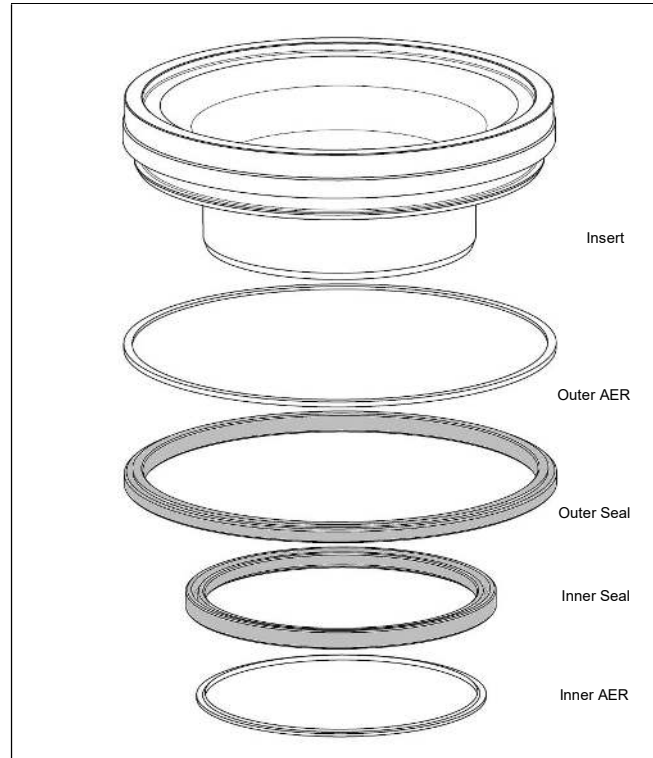

Fig. 4.9 Insert, outer AER/ Seal, inner AER/ Seal

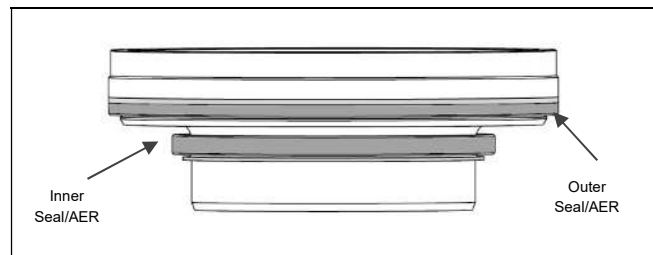

Fig. 4.10 Insert, outer AER/ Seal, inner AER/ Seal assembled

7.5 Dismantlement of the Bridge Assembly and Gearbox

After separating hydraulic head assembly and bridge assembly, proceed as follows to dismantle the bridge assembly for cleaning. Refer also to the applicable General Arrangement Drawing as necessary.

Ensure that all the exposed internal faces are in good condition and free from dirt and other foreign particles.

Remove the two cap screws holding the gearbox to the bridge. The gearbox will come away from the bridge easily. (Fig. 4.11)

Remove the cover from the gearbox by bending it gently over the intermediate gear location pin and sliding it out of the retaining groove. (Fig. 4.12)

Remove the circlip from the top face of the drive gear and push the drive gear downwards to remove it. (Fig. 4.13)

With the drive gear removed, tip the gearbox housing onto its front face and gently tap it to allow the dowel pin to drop free. The intermediate gear location pin can now be removed by gently pushing it out of the housing. (Fig. 4.14)

NOTICE Ensure that the orientation of the intermediate gear is maintained. One of the faces will be recessed to allow correct engagement with the geared socket in the bridge.

The gearbox components can now be degreased as required. Use a suitable degreasing agent. Use a brush to help clean the gear forms. Allow the gearbox components to dry thoroughly.

To dismantle the geared socket from the bridge, clamp the bridge securely in a soft jaw vice in the upside down orientation. Using a suitable blunt tool, gently tap the spring retainer (where used) out of the bridge. The compression spring and geared socket can now be removed. (Fig. 4.15)

Degrease all remaining components as described above and dry thoroughly.

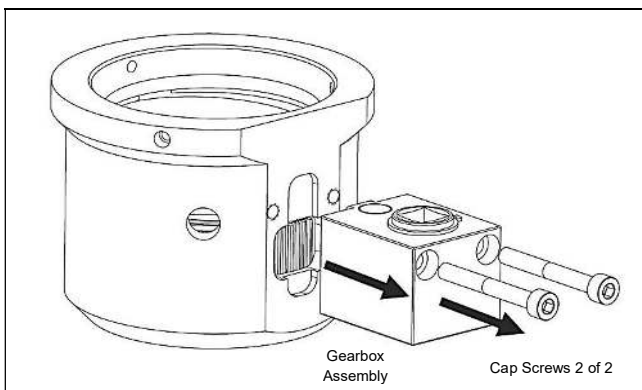

Fig. 4.11 Separation of bridge assembly and gearbox assembly

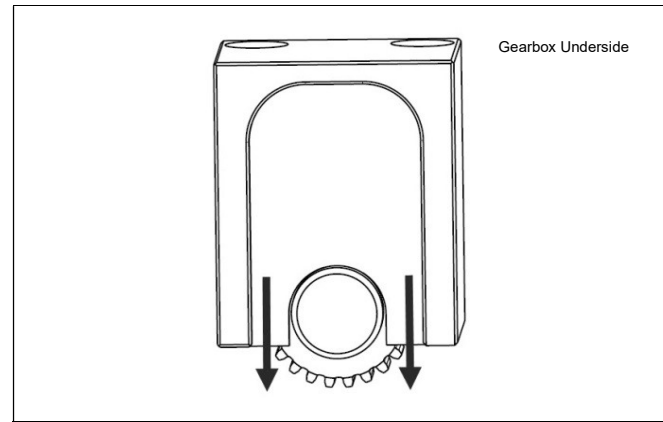

Fig. 4.12 Remove gearbox cover

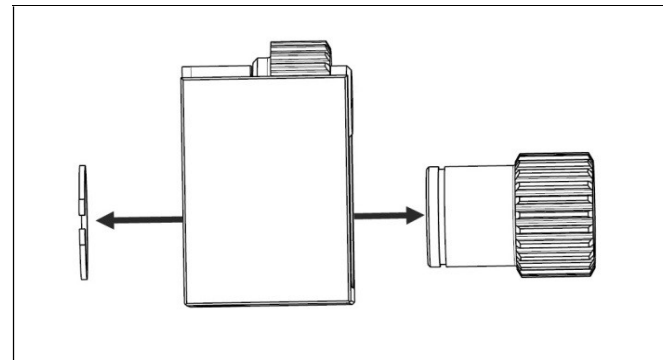

Fig. 4.13 Remove drive gear circlip and drive gear

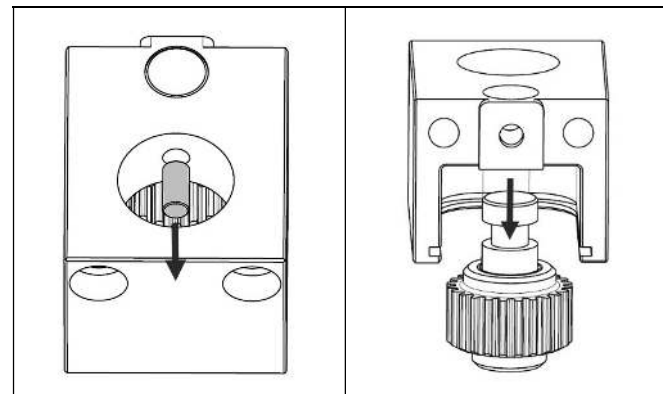

Fig. 4.14 Remove securing dowel pin followed by intermediate gear assembly

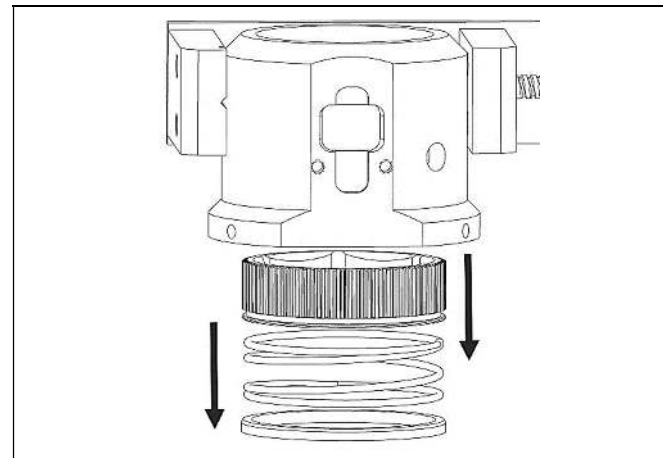

Fig. 4.15 Remove spring retainer (where used), compression springs, and geared socket

7.6 Re-assembly of the Bridge Assembly and Gearbox

Proceed as follows to re-assemble the bridge:

Ensure all bridge assembly components have been cleaned and dried and are free from oil and grease. Prior to applying fresh grease, check that all components will fit and assemble together. (Fig. 4.16)

Lightly grease the internal faces of the gearbox housing with suitable grease (as recommended in Section 10.0). (Fig. 4.17)

Lightly grease the intermediate gear location pin shaft and assemble the intermediate gear over the gear location pin, remembering to maintain the correct orientation of the recessed face on the intermediate gear. (Fig. 4.18/ Fig. 4.19)

Push the gear location pin up into its bore in the housing until the top face of the location pin is aligned with the top face of the housing. Carefully insert the small dowel pin into position so that it sits in the internal hole between the two bores in the housing and locates in the radial groove in the end of the location pin. (Fig. 4.20)

Lightly grease the drive gear shaft and gear form and push the drive gear fully up into its bore within the shrouding of the gearbox housing so that the gear teeth mesh correctly. (Fig. 4.21)

Fit the external circlip into the groove on the drive gear shaft which should now be sitting proud of the upper face of the gearbox housing. (Fig. 4.22)

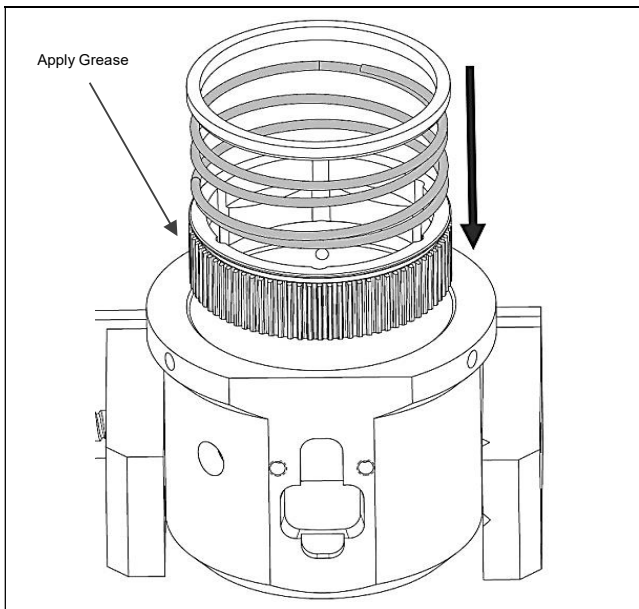

Fig. 4.16 Check internal parts fit correctly

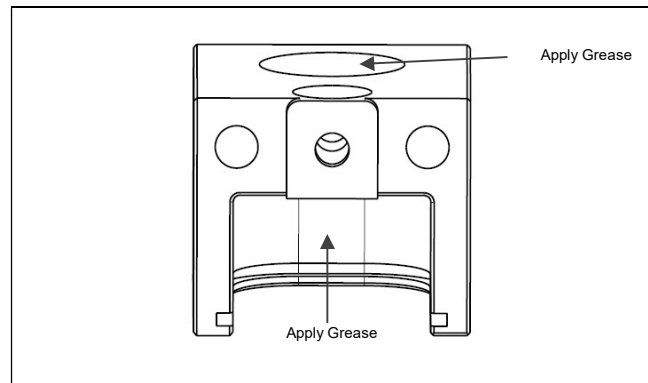

Fig. 4.17 Prepare gearbox housing

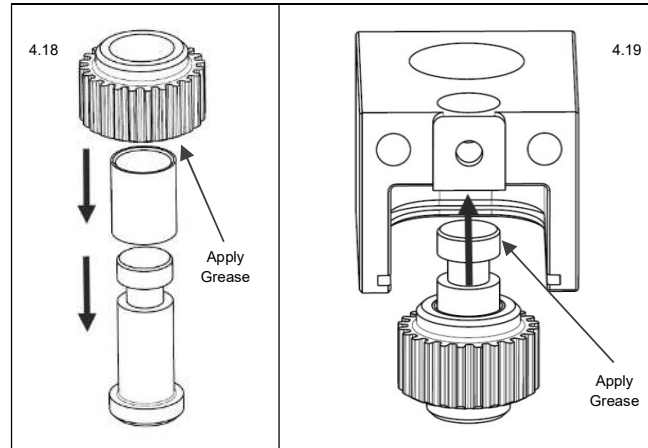

Fig. 4.18 Grease and assembly intermediate gear
Fig. 4.19 Insert intermediate gear

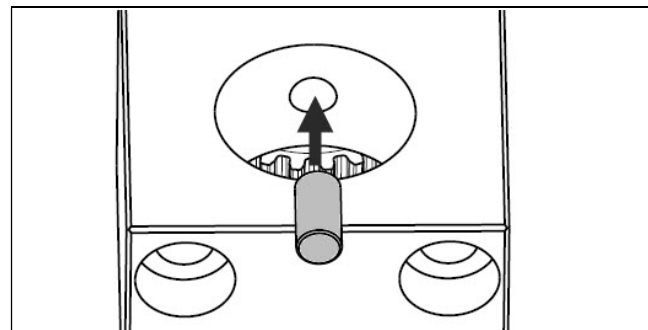

Fig. 4.20 Insert securing dowel pin

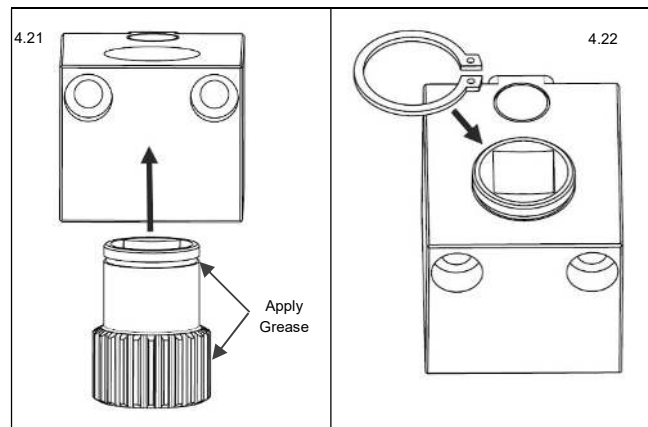

Fig. 4.21 Prepare and install drive gear
Fig. 4.22 Secure drive gear with circlip

Once both gears are fitted, apply a medium coat of grease to the intermediate gear form before sliding the gearbox cover into place. (Fig. 4.23)

NOTICE It will be necessary to bend the gearbox cover slightly in order to manoeuvre it into position over the end of the intermediate gear pin.

Clean off any excess grease from the external faces of the gearbox housing and cover and check that the two gears run freely together. (Fig. 4.24)

Assemble the gearbox to the bridge using the two socket head cap screws and tighten the screws to a torque value of 9.5ft lb/ 13 Nm. (Fig. 4.25)

Lightly grease the outside of the geared socket and fit it into the bridge bore from the top end of the bridge. The lipped end of the socket should be facing upwards. Rotate the gearbox input drive to allow the socket to drop down into position, and ensure that the gearbox functions correctly. (Fig. 4.26)

Insert the compression spring on top of the socket and then use a bench press to push the spring retainer (where used) into the bridge until the upper face of the retainer sits 9mm below the top face of the bridge. (Fig. 4.27)

NOTICE When fitting the spring retainer (where used), ensure that the outer chamfered edge of the spring retainer is facing downwards as this will obviously assist the pressing operation.

Degrease all external faces, and then place the tensioner head assembly over the bridge assembly and screw in the socket head set screws into the top of the bridge to secure the complete assembly together. (Fig. 4.28)

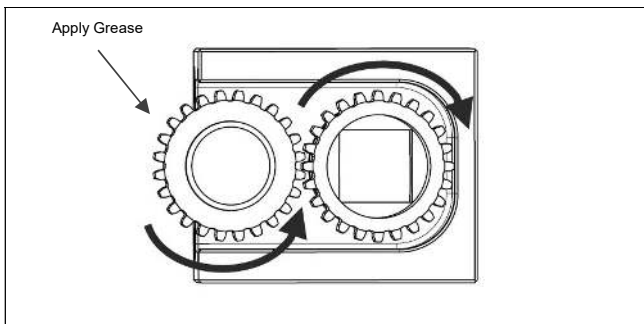

Fig. 4.23 Check fitted gears run smoothly, apply grease

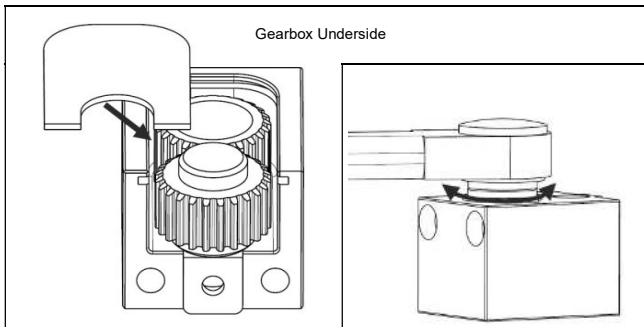

Fig. 4.24 Fit gearbox cover, check gears run smoothly

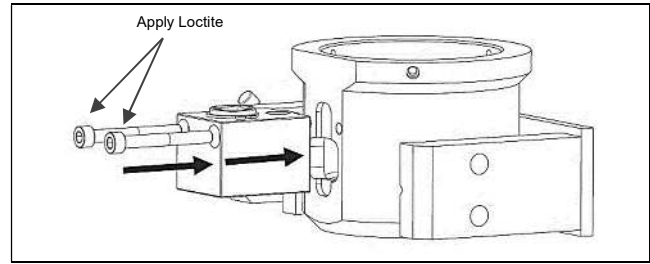

Fig. 4.25 Apply Loctite to cap screws, secure assembled gearbox to bridge

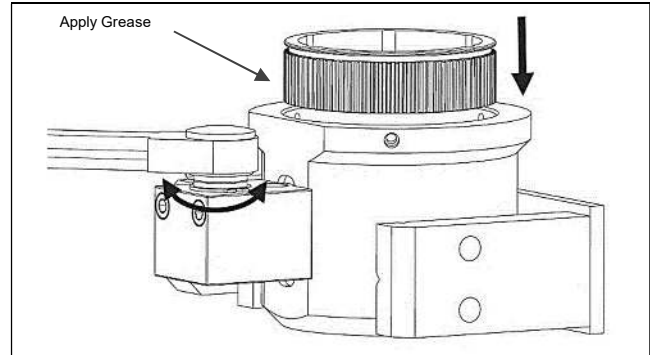

Fig. 4.26 Apply grease, insert geared socket

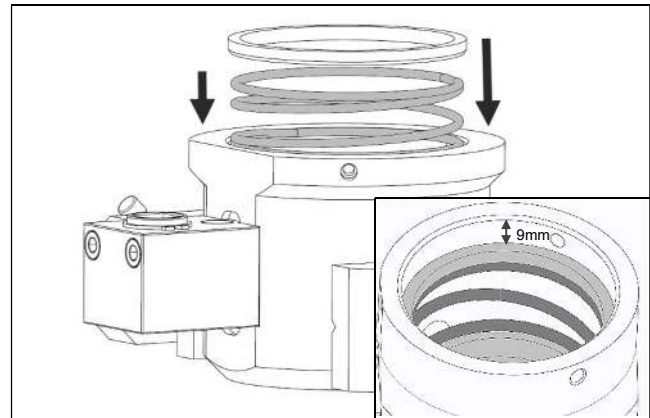

Fig. 4.27 Insert and secure compression spring and spring retainer (where used)

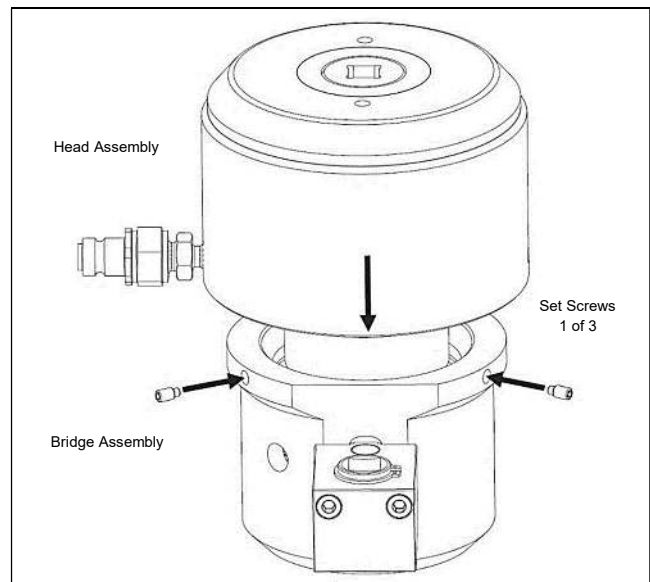

Fig. 4.28 Place head assembly onto bridge assembly, secure with grub screws

7.7 Hydraulic Fittings

Hydraulic connections are of the following types:

Hydraulic head assembly – the connections are coned with 1/8"-BSP female thread. If there is a slight leak it can usually be solved by applying the correct torque of 29.5-36.9ft lb or 40-50 Nm.

Hose – the hose end connection is a 1/4" BSP. The assembly adaptors and fittings must be fastened to a torque value of 29.5-36.9ft lb or 40-50 Nm.

NOTICE In case of performance issues not resolved by previous measures, check threads and repair or replace as needed. In the event of any further problems please consult with an Enerpac Authorized Service Centre for advice.

Hoses and Ancillaries Maintenance

Clean, then coat each quick disconnect coupling in a water repellent spray, WD40 or local equivalent is recommended, retracting and releasing the collars several times. Ensure that the collars do not seize in the retracted position. Visually inspect the entire length of the hose for damage. Test to maximum working pressure (ensure blanking plugs are inserted into end of the coupling).

8.0 STORAGE

Hydraulic Bolt Tensioning

Store tools fully retracted.

The finish will protect the tools from rust etc. but for added protection a light coating of oil or rust inhibitor should be applied to all plated surfaces.

Cover the internal threads on the inside of the puller bar and reaction nuts with a rust inhibitor.

Store tools upright.

Keep dust caps on the oil inlet nipples.

Hydraulic Hose(s)

Wipe all hoses clean and apply a light coating of oil or suitable rust inhibitor to all couplings and tee blocks.

Always keep dust caps fitted to couplings.

Pump Unit

Always store the pump upright.

Apply a light oil coating or suitable rust inhibitor to all exposed unplated metal items.

Leave the oil return to tank valve in the open position.

Always keep dust caps on inlet and outlet hydraulic fittings.

9.0 TROUBLESHOOTING

Troubleshooting Guide		
Symptom	Possible Cause	Solution
Puller bar is difficult to rotate within the tool, when assembled to the bolt.	Pressure within tool.	Open the relief valve fully to relieve pressure and allow springs to retract.
Oil is leaking from the tensioner hydraulic connection.	Cap screws attaching the manifold block are loose.	Tighten cap screws to a torque of 9.5 ft lb/ 13 Nm.
	Connection is not seating properly.	Tighten the connection to 29.5-36.9ft lb/ 40-50 Nm. Where applicable replace connection components.
Oil is leaking from the tensioner body.	Seal failure.	Replace seals.
When detensioning the bolt, the tool becomes locked onto the bolt (nut loose).	Insufficient allowance has been made for the bolt contraction.	Re-pressurise the tool to the pressure initially applied. Retighten the nut and refer to the detensioning procedure.
When detensioning the bolt the tool becomes locked onto the bolt (nut tight).	Too much allowance has been made for bolt contraction.	Re-pressurise the tool to the pressure initially applied. Rewind the nut down before turning it back one complete turn. On releasing pressure the tensioner will be free.
The nut on application is not turning when the system is under pressure.	The hydraulic hose is not connected properly to the tool.	Release the pressure and check the hose connection.
	The bolt thread may be damaged.	Release the pressure, remove the tool and rectify.
Tensioner head assembly will not retract.	Oil return to tank valve is not open.	Ensure that the oil return to tank valve is fully open.
	Coupling not assembled	Check couplings
Tensioner does not stroke (with no gauge pressure build up)	Open pump hydraulic oil return valve	Close valve
	Leaking/burst hose	Replace hose
	Leaking coupling/seals	Replace coupling/seals
	Leaking tensioner seals	Replace seals
	Defective pump unit	Check pump for oil delivery
Tensioner does not stroke (with gauge pressure build up)	Coupling not assembled	Check couplings
	Incorrect hose assembly	Check hose(s)
Hoses difficult to assemble	Damaged coupling	Replace coupling
	Coupling locking collars not fully screwed back	Screw back collars
	Internal pressure in head assembly due to over tightening puller bar	Unscrew puller bar
The hydraulic hose will not couple together with the tool at zero pressure.	Slight hydraulic pressure inside the hose caused by previously disconnecting the hose before the oil pressure had reached zero. Oil return to tank valve may be defective.	Release the pressure inside the hose by loosening the swivel end fitting.
Maximum pressure cannot be achieved, even when pump is running continuously	Leaking couplings	Replace suspect couplings
	Leaking tensioner seals	Replace suspect seals
	Hydraulic oil return valve	Fully close valve or replace
	Air in system	Run pump for short period with oil return valve open

10.0 TECHNICAL DATA

Recommended lubricant to be used:

Molybdenum disulphide based thread lubricant with a co-efficient of friction of 0.12 or similar

 <p>Side View</p>	 <p>Top View</p>		
 <p>Top View of Bolt and Nut</p>			
<p>Puller bar Square Drive Size:</p>		<p>Gearbox Square Drive Size:</p>	
<p>• 3/8" / 9.5mm</p>	<p>• 3/8" / 9.5mm (cont.)</p>	<p>• 3/8" / 9.5mm</p>	<p>• 3/8" / 9.5mm (cont.)</p>
<p>Ranges: PGTD20S – All Models PGTD24S – All Models PGTD27S – All Models PGTD30S – All Models PGTD33S – All Models PGTD39S – All Models PGTD45S – All Models PGTD48S – All Models PGTD52S – All Models PGTD56S – All Models PGTD60S – All Models</p>	<p>Ranges: PGTD64S – All Models PGTD68S – All Models PGTD72S – All Models</p>	<p>Ranges: PGTD20S – All Models PGTD24S – All Models PGTD27S – All Models PGTD30S – All Models PGTD33S – All Models PGTD39S – All Models PGTD45S – All Models PGTD48S – All Models PGTD52S – All Models PGTD56S – All Models PGTD60S – All Models</p>	<p>Ranges: PGTD64S – All Models PGTD68S – All Models PGTD72S – All Models</p>
	<p>• 1/2" / 13mm</p>		<p>• 1/2" / 13mm</p>
	<p>Ranges: PGTD36S – All Models PGTD42S – All Models</p>		<p>Ranges: PGTD36S – All Models PGTD42S – All Models</p>

Table 1, Technical Data, PGT-Series Single Stage Tensioner

Model Number	Measurement	Bolt Diameter	Bar Size Designation	Nut A/F	Maximum Pressure		Hydraulic Pressure Area (sq)	Load Capacity	Stroke	Dimension					Weight	Minimum Bolt Protrusion	Maximum Bolt Protrusion
					psi	bar				A	B	C	D	E			
PGTS2030S	in	0.79	M20 x 2.5	1.18	21750	1500	2.10	45800 lbf	0.28	2.52	2.52	1.26	3.19	3.07	4.41 lbs	1.73	2.17
PGTS2030SW	mm	20		30													

S = Straight Nipple	SW = Swivel Nipple	G = Gear Box	C = Counter
---------------------	--------------------	--------------	-------------

Model Number	Measurement	Bolt Diameter	Bar Size Designation	Nut A/F	Maximum Pressure		Hydraulic Pressure Area (sq)	Load Capacity	Stroke	Dimension					Weight	Minimum Bolt Protusion	Maximum Bolt Protusion
					psi	bar				A	B	C	D	E			
PGTS2436S PGTS2436SW	in	0.94	M24 x3.0	1.42	21750	1500	3.02	65600 lbf	0.28	3.03	3.03	1.22	3.86	3.2	6.39 lb	1.93	2.44
	mm	24		36			1947	292.1 kn	7	77	77	31	98	81.4	2.9 kgs	49	62
PGTS2742S PGTS2742SW	in	1.06	M27 x3.0	1.65	21750	1500	4.10	89200 lbf	0.31	3.62	2.95	1.34	5.08	3.27	10.58 lb	2.36	2.76
	mm	27		42			2646	396.9 kn	8	92	75	34	129	83	4.8 kgs	60	95
PGTS3046S PGTS3046SW	in	1.18	M30 x3.5	1.81	21750	1500	4.97	108000 lbf	0.31	3.9	3.35	1.5	5.28	3.46	12.79 lb	2.68	2.87
	mm	30		46			3204	480.7 kn	8	99	85	38	134	88	5.8 kgs	68	73
PGTS3350S PGTS3350SW	in	1.3	M33 x3.5	1.97	21750	1500	6.14	133600 lbf	0.31	4.17	3.54	1.57	5.59	3.54	14.88 lb	2.95	3.94
	mm	33		50			3960	594.0 kn	8	106	90	40	142	90	6.8 kgs	75	100
PGTS3655S PGTS3655SW	in	1.42	M36 x4.0	2.17	21750	1500	6.92	150600 lbf	0.35	4.37	3.54	2.19	5.04	3.75	14.11 lb	2.80	3.74
	mm	36		55			4467	670.1 kn	9	111	90	56	128	95.2	6.4 kgs	71	95
PGTS3960S PGTS3960SW	in	1.54	M39 x4.0	2.36	21750	1500	8.62	187600 lbf	0.39	4.86	4.09	1.81	6.3	3.78	21.54	3.5	4.53
	mm	39		60			5561	834.1 kn	10	123.5	104	46	160	96	9.8 kgs	89	115
PGTS4265S PGTS4265SW	in	1.65	M42 x4.5	2.56	21750	1500	9.70	211200 lbf	0.39	5.28	4.53	2.65	6.97	3.9	20.94 lb	3.11	4.53
	mm	42		65			6259	938.8 kn	10	134	115	67	177	99	9.5 kgs	79	115
PGTS4570S PGTS4570SW	in	1.77	M45 x4.5	2.76	21750	1500	11.63	253200 lbf	0.39	5.63	4.69	2.07	6.61	4.02	29.1 lb	3.86	4.57
	mm	45		70			7505	1125.8 kn	10	143	119	53	168	102	13.2 kgs	98	116
PGTS4875S PGTS4875SW	in	1.89	M48 x5.0	2.95	21750	1500	13.00	283000 lbf	0.39	5.98	4.92	2.2	6.22	4.17	29.32 lb	4.06	4.69
	mm	48		75			8390	1258.4 kn	10	152	125	56	158	106	13.3 kgs	103	119
PGTS5280S PGTS5280SW	in	2.05	M52 x5.0	3.15	21750	1500	15.65	340400 lbf	0.39	6.5	5.28	2.3	6.73	4.25	39.46 lb	4.17	4.65
	mm	52		80			10094	1514.1 kn	10	165	134	59	171	108	17.9 kgs	106	118
PGTS5685S PGTS5685SW	in	2.20	M56 x5.5	3.35	21750	1500	18.08	393400 lbf	0.39	6.97	5.59	2.44	6.69	4.41	44.97 lb	4.57	5.04
	mm	56		85			11663	1749.5 kn	10	177	142	62	170	112	20.4 kgs	116	128
PGTS6090S PGTS6090SW	in	2.36	M60 x5.5	3.54	21750	1500	20.89	454600 lbf	0.39	7.48	5.98	2.6	7.32	4.53	54.59 lb	4.86	5.39
	mm	60		90			13474	2021.2 kn	10	190	152	66	186	115	24.8 kgs	123.5	137
PGTS6495S PGTS6495SW	in	2.52	M64 x6.0	3.74	21750	1500	23.74	516600 lbf	0.39	7.87	6.26	2.7	8.15	4.65	67.68 lb	5.39	5.91
	mm	64		95			15315	2297.3 kn	10	200	159	69	207	118	30.7 kgs	137	150
PGTS68100S PGTS68100SW	in	2.68	M68 x6.0	3.94	21750	1500	27.11	590000 lbf	0.39	8.41	6.65	2.85	8.11	4.84	75.62 lb	5.35	5.83
	mm	68		100			17493	2623.9 kn	10	213.5	169	73	206	123	34.3 kgs	136	148
PGTS72105S PGTS72105SW	in	2.83	M72 x6.0	3.94	21750	1500	30.69	667800 lbf	0.39	8.86	7.01	2.99	8.78	4.96	88.74 lb	5.94	6.57
	mm	72		105			19797	2969.6 kn	10	225	178	76	223	126	40.3 kgs	151	167

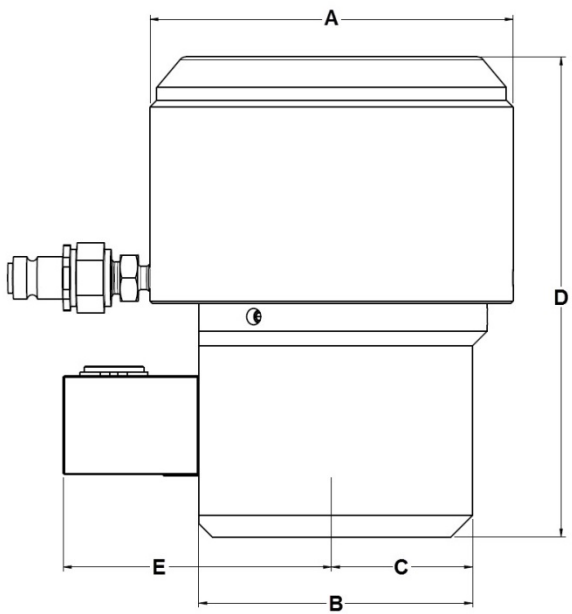
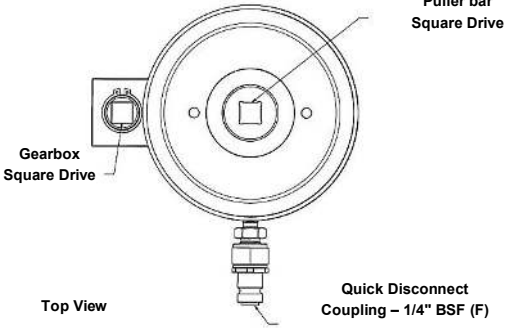
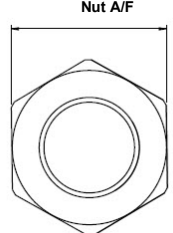
S = Straight Nipple	SW = Swivel Nipple	G = Gear Box	C = Counter
---------------------	--------------------	--------------	-------------

ENERPAC 

www.enerpac.com