

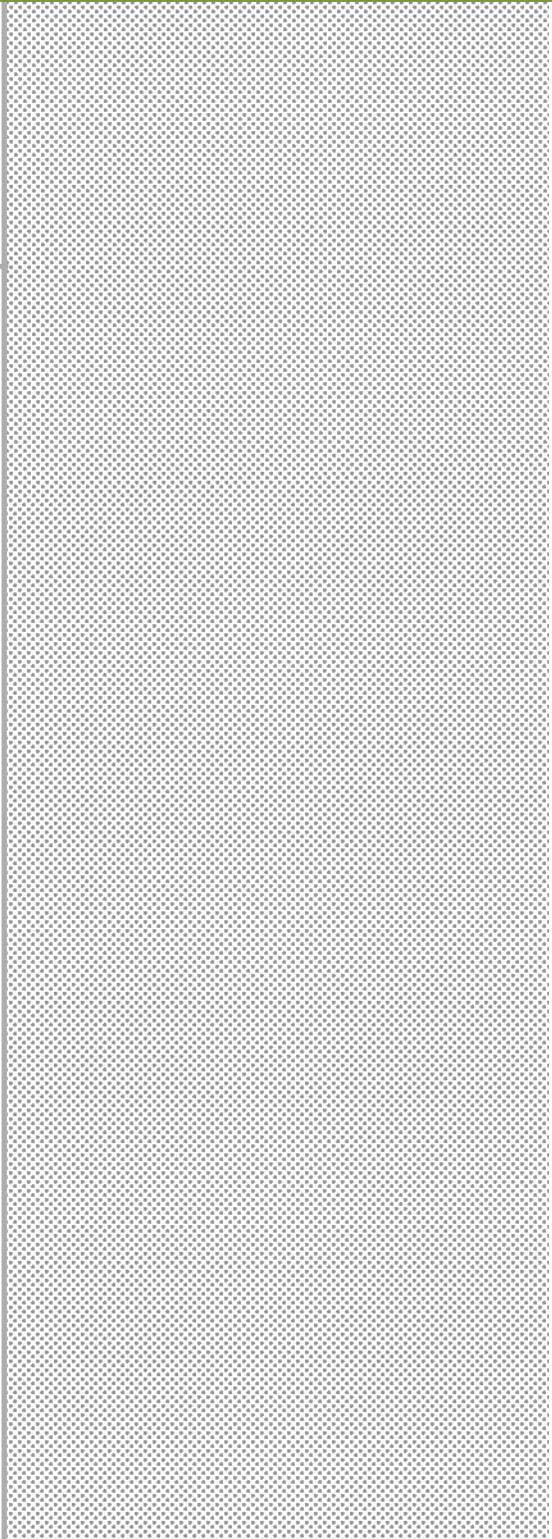

SG13TE SG15TE

SECURE-GRIP
HYDRAULIC
FLANGE
SPREADERS

Torque and tension specialist



CONTENTS

1. INTRODUCTION
2. TOOL SAFETY
 - 2.1 GENERAL SAFETY
 - 2.2 PERSONNEL COMPETENCY
 - 2.3 DISCLAIMER
 - 2.4 DEFINITION OF TERMS
 - 2.5 HAZARDS
3. TOOL OPERATION
 - 3.1 GENERAL GUIDANCE
 - 3.2 COLLET SELECTION
 - 3.3 BOLT HOLE MEASUREMENT
 - 3.4 COLLET REPLACEMENT
 - 3.5 TOOL INSTALLATION AND OPERATION
 - 3.6 COLLET LEG SUBASSEMBLY INSTALLATION
 - 3.7 RESTRICTED ACCESS INSTALLATION AND OPERATION
 - 3.8 VALVE, SPADE OR BLIND REMOVAL, INSTALLATION AND OPERATION
 - 3.9 OVERALL DIMENSIONS
4. TOOL MAINTENANCE
 - 4.1 INSPECTION
 - 4.2 DISASSEMBLY
 - 4.3 SERVICING
 - 4.4 STORAGE & TRANSPORTATION
 - 4.5 LONG-TERM STORAGE - MAINTENANCE PLAN
5. SG13TE
 - 5.1 TOOL CAPABILITIES
 - 5.2 KIT CONTENTS
6. SG15TE
 - 6.1 TOOL CAPABILITIES
 - 6.2 KIT CONTENTS
7. TROUBLESHOOTING
 - 7.1 SG13TE/SG15TE TROUBLESHOOTING
8. SECURE GRIP RANGE OF APPLICATION
9. REGULATORY INFORMATION
10. PARTS LISTS & SERVICE KITS

06/11/2019

1.

INTRODUCTION

The Equalizer™ SG Secure Grip tools are aids for use in normal maintenance and installation procedures. The tools can be used during pipework construction, commissioning or during routine maintenance.

The Hydraulic Secure Grip Flange Spreading Tools are used to spread flanges with little or no access gap producing a spreading force up to:

- 26 T (260 kN) for the SG13TE when used in pairs
- 30 T (300 kN) for the SG15TE when used in pairs

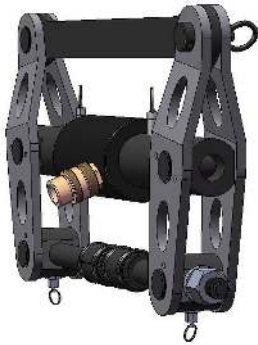

It is essential that the user familiarises themselves with the contents of this manual prior to using the tool.

This manual contains information for the following tools:

- SG13TE Secure Grip Hydraulic Flange Spreader
- SG15TE Secure Grip Hydraulic Flange Spreader

2.

TOOL SAFETY

2.1

GENERAL SAFETY

These instructions cover the safe operation and maintenance of THE EQUALIZER **SG13TE** and **SG15TE** SECURE GRIP HYDRAULIC FLANGE SPREADING tools. The use of these tools should be as part of a broader task-based risk assessment, which should be carried out by the operation supervisor or other competent person.

Failure to comply with the safety information contained within this manual could result in personal injury or equipment damage. Read all instructions, warnings and cautions carefully, and follow all safety precautions.

The safety of the operator, any assisting personnel and the general public is of paramount importance. Always work in accordance with applicable national, local, site & company-wide safety procedures.

2.2

PERSONNEL COMPETENCY

Only personnel deemed competent in the use of mechanical and hydraulic equipment should use these tools.

2.3

DISCLAIMER

Equalizer cannot be held responsible for injury or damage resulting from unsafe product use, lack of maintenance or incorrect product and/or system operation. If in doubt as to the safety precautions and applications, contact Equalizer using the contact details at the back of this manual.

2.4

DEFINITION OF TERMS

A **CAUTION** is used to indicate correct operating or maintenance procedures and practices to prevent damage to, or destruction of equipment or other property.

A **WARNING** indicates a potential danger that requires correct procedures or practices to avoid personal injury.

A **DANGER** is only used when your action or lack of action may cause serious injury or even death.



DO: an illustration showing how the tool should be used.



DON'T: an illustration showing an incorrect way to use a tool.

2.5

HAZARDS



WARNING: ensure all hydraulic components are rated to a safe working pressure of 700 bar (10 000psi).



WARNING: Do not overload equipment. The risk of hydraulic overloading can be minimised by using the Equalizer Hand Pump, which has a factory-set safety valve preventing the safe working pressure being exceeded.

If alternative hydraulic pumps are used, ensure that there are adequate systems to limit the working pressure to 700 bar (10 000 psi).



CAUTION: ensure components are protected from external sources of damage, such as excessive heat, flame, moving machine parts, sharp edges and corrosive chemicals.



CAUTION: Take care to avoid sharp bends and kinks in hydraulic hoses. Bends and kinks can cause severe back-up pressure and cause hose failure. Protect hoses from dropped objects; a sharp impact may cause internal damage to hose wire strands. Protect hoses from crush risks, such as heavy objects or vehicles; crush damage can cause hose failure.



WARNING: Applying pressure to a damaged hose may cause it to rupture.



WARNING: Immediately replace worn or damaged parts. Use only genuine Equalizer parts from approved distributors or service centres. Equalizer parts have been engineered and manufactured to be fit-for-purpose.



DANGER: To minimise risk of personal injury keep hands and feet away from the tool and workpiece during operation.



WARNING: Always wear suitable clothing and Personal Protective Equipment (PPE). Do not handle pressurised hoses; escaping oil under pressure can penetrate the skin, causing serious injury. Seek medical attention immediately if oil penetration is suspected.



WARNING: Only pressurize complete and fully connected hydraulic systems. Do not pressurize systems that contain unconnected couplers.



CAUTION: Do not lift hydraulic equipment by the hoses or couplers. Use only the designated carrying handles.



CAUTION: Lubricate tools as directed in this manual prior to operation. Use only approved lubricants of high quality, following the lubricant manufacturers instructions.



CAUTION: Only use the designated anchor point for fixing the lanyard. Do not attach the lanyard to the plastic handle.



DANGER: Care should be taken when using the lanyard to avoid entanglement with body parts.



The vibration total value to which this tool is subjected does not exceed 2.5 m/s².



WARNING: Never place fingers in a joint held by an activated tool



CAUTION: Never hammer or force the tool into a bolt hole; if it does not fit easily you are using the wrong size of tool.

3.

TOOL OPERATION

3.1 GENERAL GUIDANCE

The Secure-Grip Mechanical Tools spread flange joints by engaging collets into the bolt-holes. They can easily spread flange joints with zero access gap, which traditional wedge-type flange spreaders cannot spread.

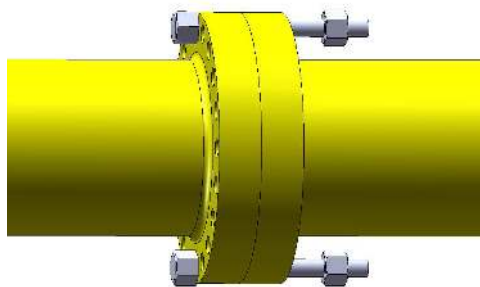

The collets are suited to the sizes of the bolt-holes and should be selected prior to commencing work by following the instructions in this section.

Replacement collets or different collets to suit different bolt-hole sizes are available from a local Equalizer distributor.

3.2 COLLET SELECTION



WARNING: It is important that the correct size of collet is used. An undersized collet could allow the collet holder to pull through its bore. An oversized collet has the potential to become jammed in the bolt-hole.

To select the applicable tool and collet for your flange please refer to the Secure-Grip application charts at the back of this manual (section 8).

The SG range of Secure-Grip tools have a range of collets which are applicable to the following bolts and flange bolt-hole diameters shown in the table below.

If the specification of the flange is unknown then the vernier calliper supplied in the kit should be used to determine the correct collet.

Minimum bolt-hole diameter (mm)	Maximum bolt-hole diameter (mm)	COLLET	TOOL
38 mm (1.50")	42 mm (1.65")	M39 (1 1/2")	SG13TE
41 mm (1.61")	45 mm (1.77")	M42 (1 5/8")	
44 mm (1.73")	49 mm (1.93")	M45 (1 3/4")	
47.5 mm (1.87")	52 mm (2.05")	M48 (1 7/8")	SG15TE
50.5 mm (1.99")	56 mm (2.21")	M52 (2")	
55.5 mm (2.19")	62 mm (2.44")	M56 (2 1/4")	

3.3 BOLT HOLE MEASUREMENT

To ensure a true measurement is taken, hold the vernier calliper:

- square to the flange face
- in the middle of the bolt-hole

It is important that the vernier calliper is held in the middle of the bolt-hole, and not held at an angle to the flange face, nor used on a bolt-hole which is worn, damaged or distorted, as these actions may result in the selection of an incorrect size of collet.

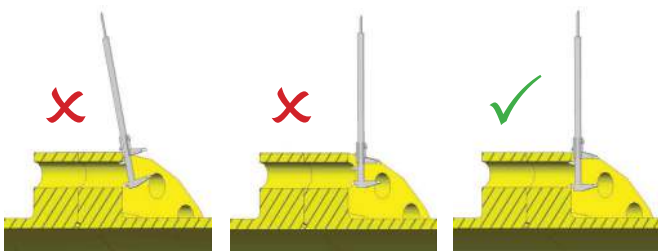

To confirm that the bolt-hole is round, take two separate measurements with the vernier calliper turned through 90° between measurements.

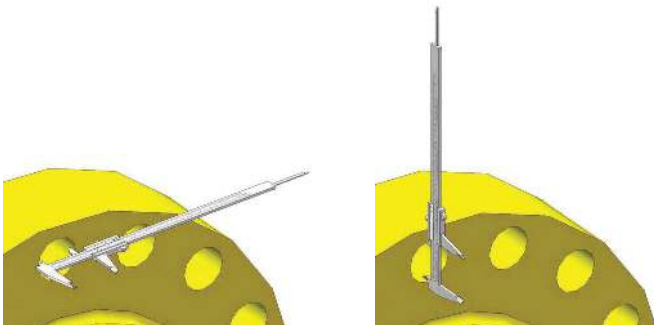

To read the measurement from the vernier calliper, scan along the desired scale from left to right. In this example, the major figure is 60 mm, this is added to the minor figure of 8 mm (indicated by where the vernier scale aligns with the main scale), giving a total measurement of 68 mm.

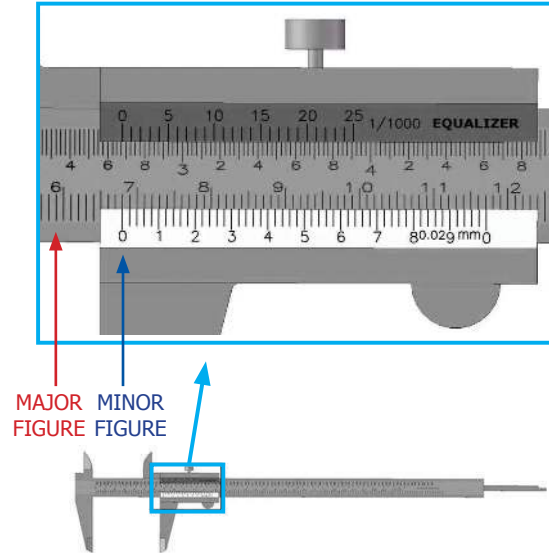

With a bolt-hole size of 68 mm, the operator can determine which collet and tool is appropriate to this flange by referring to the table. For example: 68 mm falls within the 63 mm minimum and 69 mm maximum bolt-hole sizes.

Therefore, collet identification is M64 / 2 1/2"

If the measurement contains fractions of a millimetre the method of reading the vernier calliper is slightly different. In this example, the major figure is 40 mm (read in the same way as previously described). The minor figure is 7 mm (read to the left of the zero). The fraction is 0.5 mm (read from where the vernier scale lines up with the main scale). This gives a total measurement of 47.5 mm.

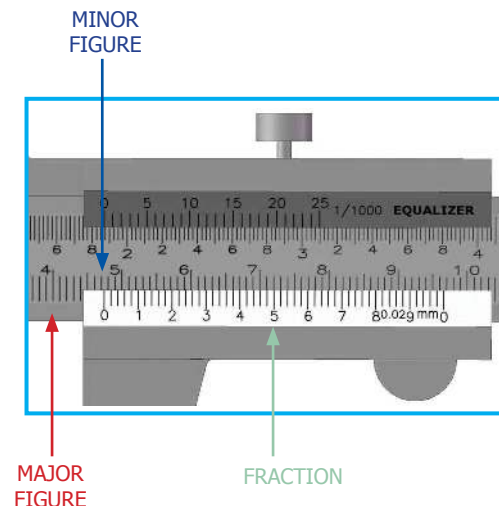

Each tool in the Secure-Grip range comes with the appropriate sizes of Collets for that tool. If the Collet labelling is worn or missing, then the Collet can be measured to ensure that the correct size is selected.



An accurate measurement can only be obtained with the Collet mounted on the Collet Holder. To do this:

- Remove the Collet Head Assembly from the tool and disassemble (see Section 3.4 for details)
- Slide the Collet over the Collet Holder
- Measure the centre section of the Collet with the vernier calliper
- Identify the Collet using the chart below and select the correct size for the flange



WARNING: The Secure-Grip collets are consumable items. The lifespan of a collet will vary depending on the flange materials with which it is used. To increase the lifespan of the collets it is recommended that they are flipped through 180° on the collet holder, this will produce more even wear across the four ridges on the outer profile of the collet. See Section 3.4 for details on collet removal and replacement.

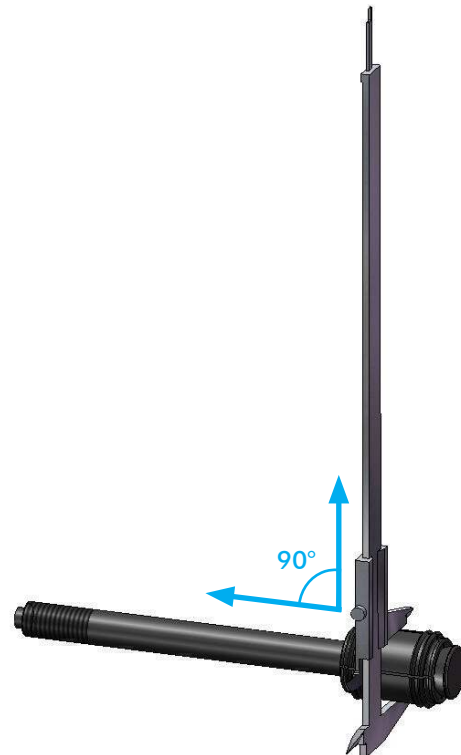

Centre Section Ø	COLLET	Minimum bolt-hole diameter (mm)	Maximum bolt-hole diameter (mm)
36 mm	M39 (1 1/2")	38 mm (1.50")	42 mm (1.65")
39 mm	M42 (1 5/8")	41 mm (1.61")	45 mm (1.77")
40.5 mm	M45 (1 3/4")	44 mm (1.73")	49 mm (1.93")
44.5 mm	M48 (1 7/8")	47.5 mm (1.87")	52 mm (2.05")
47.5 mm	M52 (2")	50.5 mm (1.99")	56 mm (2.21")
52.5 mm	M56 (2 1/4")	55.5 mm (2.19")	62 mm (2.44")

3.4 COLLET REPLACEMENT

Once the correct collet has been selected it may be necessary to change the collet on the tool:

Place the tool on its side on a work bench or flat surface. Unscrew and remove the drive nut.

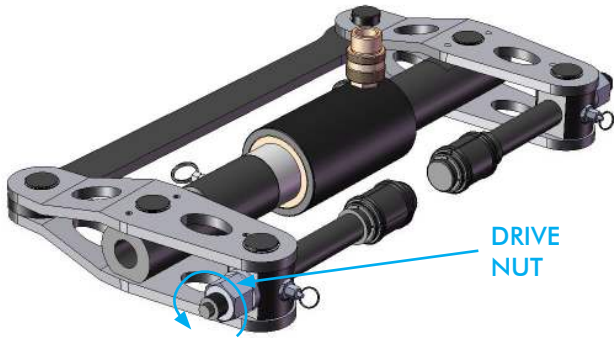

Pull the collet spring plunger ring out, and remove the collet head assembly from the tool.

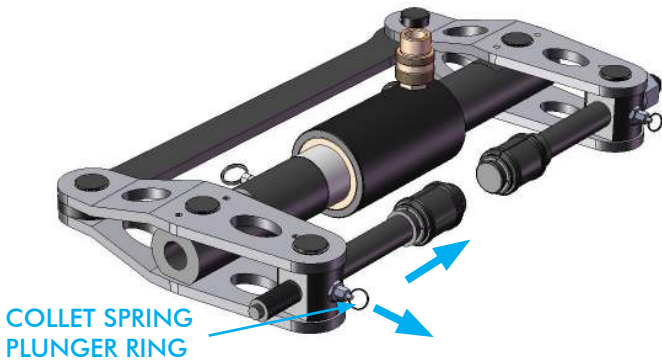

Slip the drive tube and drive cone off the collet holder. Remove the collet from the collet holder and replace it with the correct collet for the flange to be separated.



Repeat the operation for the opposite Collet Leg Subassembly.

Reverse the above procedure to re-assemble the tool. Care should be taken to ensure the slot in the collet holder is aligned with the collet spring plunger.

3.5 COLLET LEG SUBASSEMBLY INSTALLATION

The Collet Leg Subassemblies should be the first parts of the tool fitted to the flange joint.

The Collets from each assembly should be installed into the bolt-hole of the flanges on either side of the joint to be spread. Care should be taken to ensure that the Collets are engaged in the correct position.

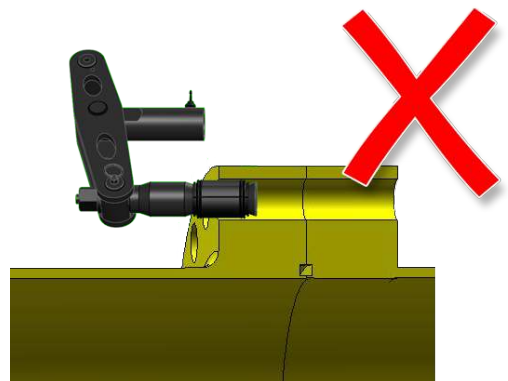
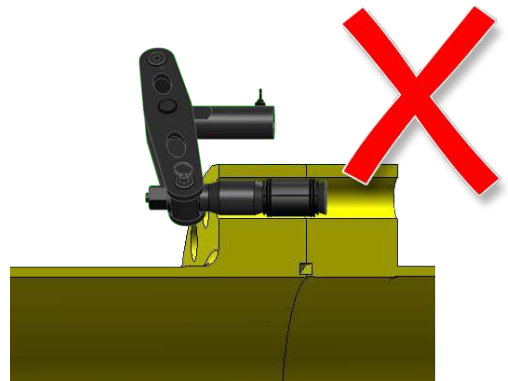
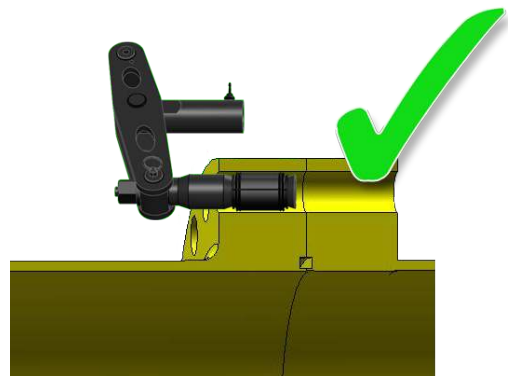

If a spacer, blind or valve is installed between the flanges, care should be taken to ensure that the Collet or Collet Holder do not extend beyond the flange bolt hole.

3.6 TOOL INSTALLATION AND OPERATION

Once the correct Collet has been selected and mounted, tool operation can commence.



WARNING: Before attaching the tool ensure at least two flange bolts remain in place 180 degrees apart with nuts loosened sufficiently enough for flange work to be carried out. These bolts will reduce lateral flange movement during flange spreading.

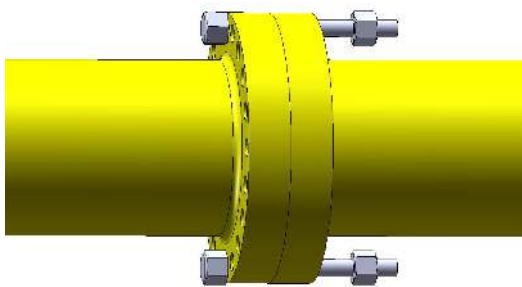

Before installation can begin the tool must be dismantled into three parts.

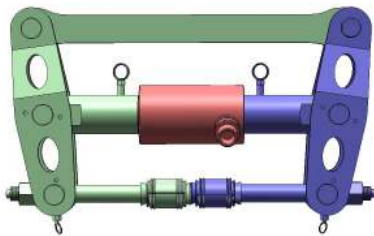

Lay the tool on a flat surface. Pull the cantilever pin out and rotate the cantilever out of position.

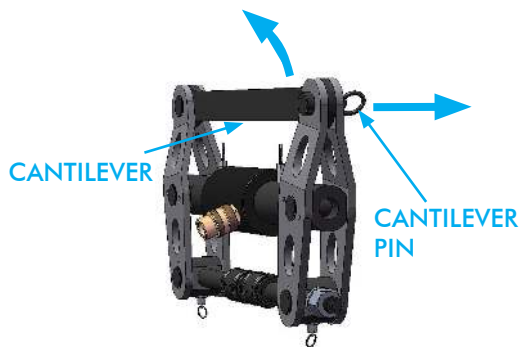

Pull on the left hand actuator spring plunger and pull the actuator from the actuator to leg connector. Repeat this on the right hand side.

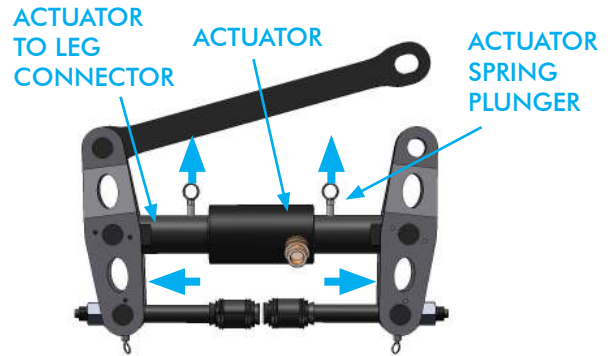

The tool should now be in three parts - two halves and the actuator.

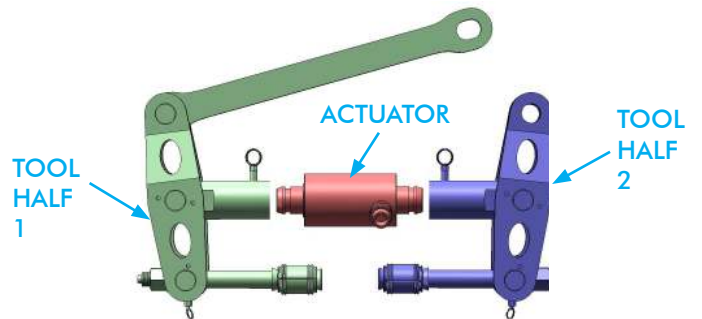

Measure the thickness of the flange using the vernier calliper provided. Lock the calliper in position by tightening the locking screw.

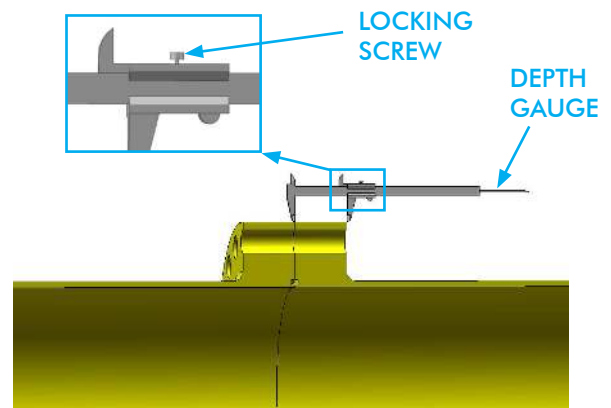

Select a suitable bolt-hole in which to attach the tool. Insert the depth gauge part of the vernier calliper into the bolt hole keeping the base of the calliper flush with the bolting face of the flange

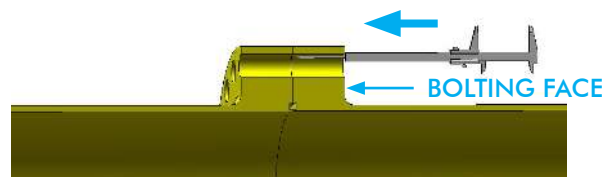

Insert the collet on the first half of the tool into the the opposite end of the same bolt-hole until it touches the end of the depth gauge (so that the collet is fully through one flange but not entering the other)

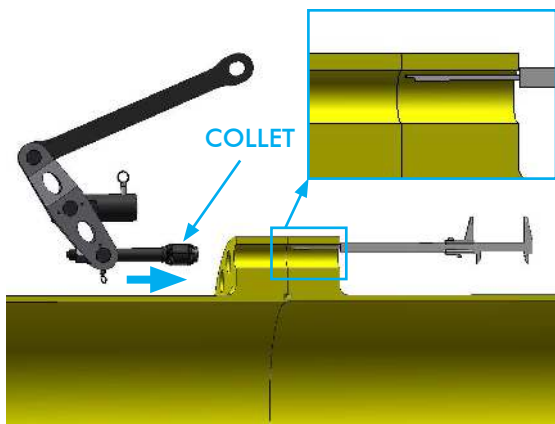

Tighten the drive nut with the 1/2" square drive flexible handle. The first half of the tool will now have a secure hold in the bolt-hole.

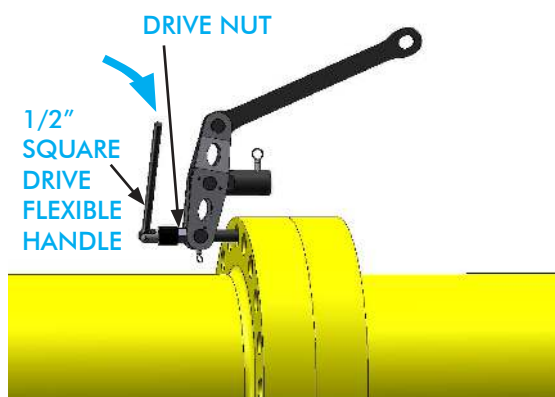

Insert the collet on the second half of the tool in to the bolt-hole until it touches the collet on the first half of the tool, and tighten the drive nut using the 1/2" square drive flexible handle. The second half of the tool will now have a secure hold in the bolt-hole

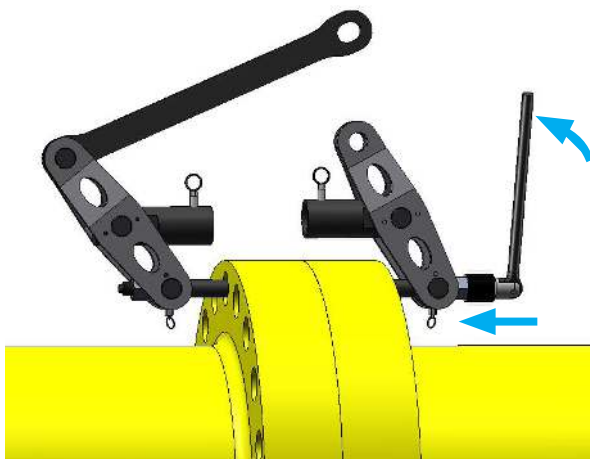

Insert one side of the actuator into each 'actuator to leg connector'. On both sides push the actuator until you feel the actuator spring plunger click.

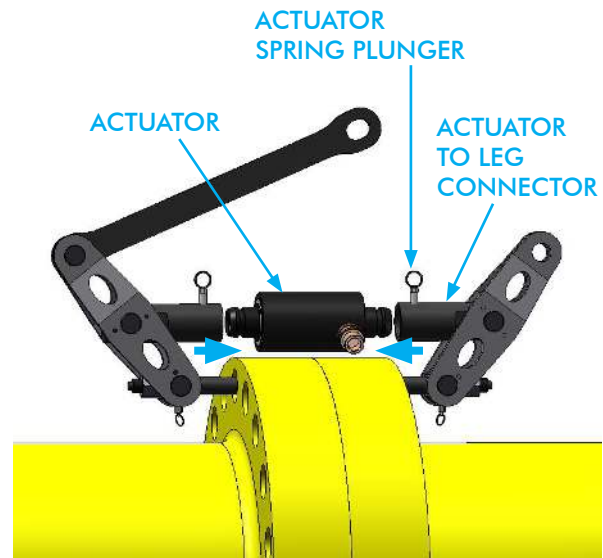

Rotate the cantilever into position, and secure by sliding the cantilever pin (through the hole at the top of the leg and the hole in the cantilever) until fully home.

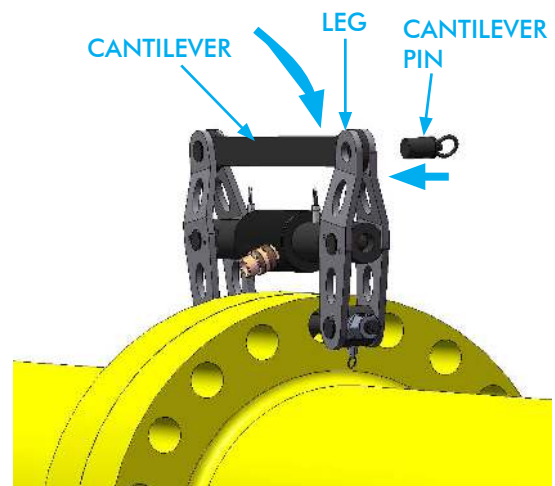

Select the bolt-hole 180° opposite the tool you have just attached and repeat the above steps for the second tool.

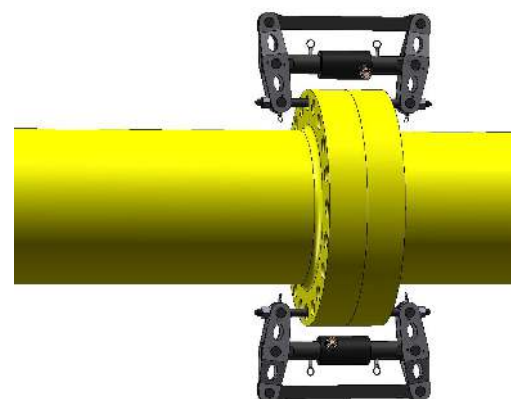



If more than two tools are being used they should be attached at an equal spacing around the flange joint.

Continue spreading the flange until the access gap required is achieved, or until the maximum pressure or tool travel has been reached.
If the flange does not spread refer to section 8.

Connect the hand pumps to the hydraulic hoses, and the hydraulic hoses to the actuators on each tool. Ensure that all couplers are fully hand tightened and the release valves are closed hand tight.

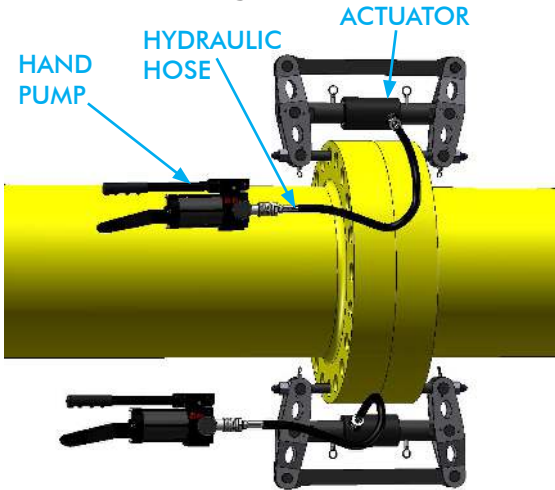

Tool type	Max. distance
SG13TE	115mm (4.53")
SG15TE	100mm (3.94")

Flange spreading can now begin. Give the first tool four strokes on the hand pump, then give the same to the second. As the flange is separating, measure the gap at both tools, and if necessary adjust the number of strokes on one side to ensure the flange faces are kept parallel.

Pressure	SG13TE spreading force		SG15TE spreading force	
	Bar	psi		
138	2000	2.6	3	
276	4000	5.2	6	
414	6000	7.8	9	
552	8000	10.4	12	
MAX.	690	10,000	13	15

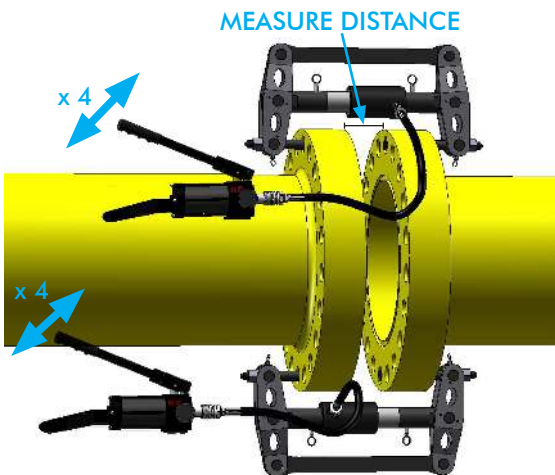

Once the flange has been separated and prior to any maintenance works the safety blocks must be inserted between the flanges. These are held in position by replacing two of the flange bolts.

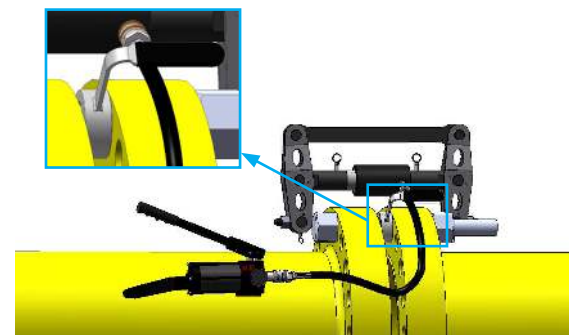
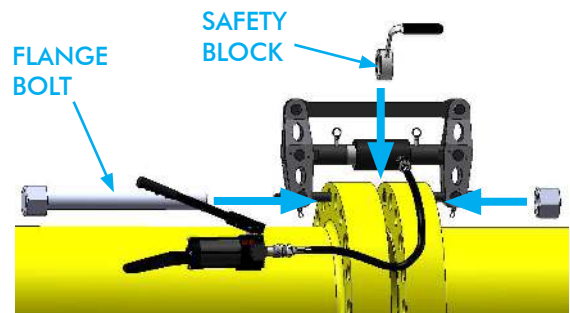

WARNING: Never place fingers in a joint held by an activated tool

Following any maintenance works and prior to closing the flange joint, the safety block must be removed. The release valves on the hand pumps should now be turned anti-clockwise gently and evenly, adjusting as necessary to keep the flanges parallel until the flange is fully closed and there is no load on the tools. The tools can then be removed by reversing the installation procedure.

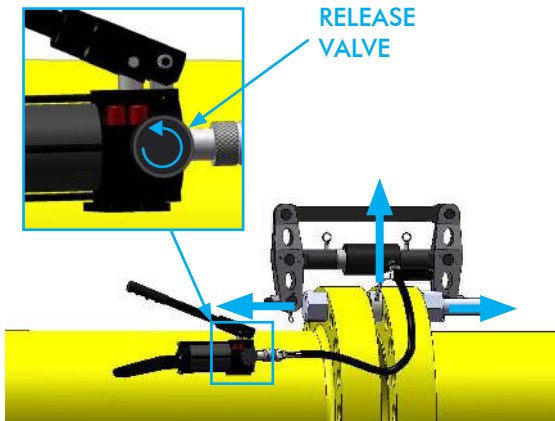

Pass the collet head assembly through both bolt-holes from the open access side.

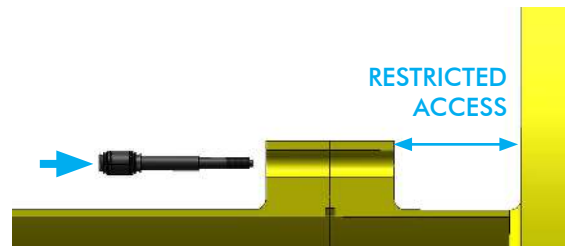

Refit the tool half on to the collet holder.

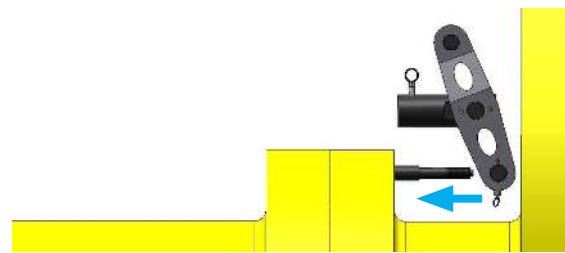

Refit the drive nut.

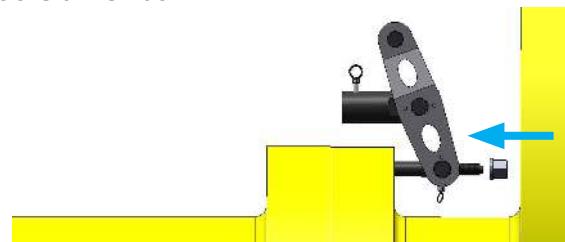

3.7 RESTRICTED ACCESS INSTALLATION AND OPERATION

The Secure-Grip hydraulic tools are also ideal for use where access to the flange is restricted. As in the standard operation, two tools should be used in order to avoid flange distortion, with the tools positioned 180° from each other on the flange.

Before beginning the following procedure, complete steps 1 - 4 of the standard installation procedure

On one half of the tool unscrew and remove the drive nut. Pull the collet spring plunger ring out, and remove the collet head assembly from the tool.

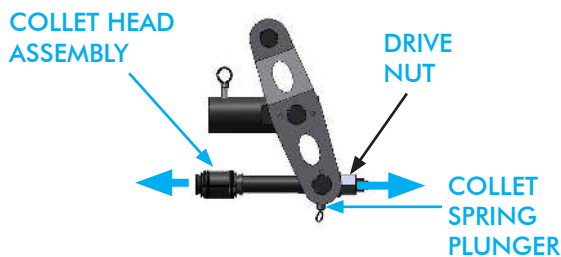

Measure the thickness of the flange with the vernier calliper provided and using the vernier calliper as a depth gauge, adjust the position of the collet until it touches the end of the depth gauge (so that the collet is fully through one flange but not entering the other).

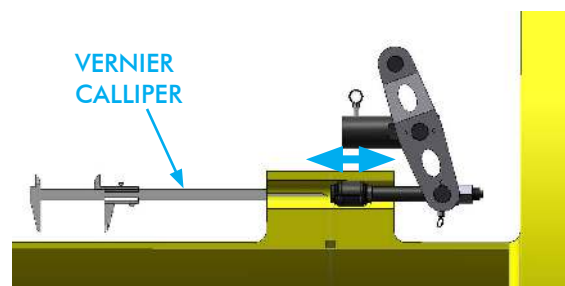

The procedure can now be completed by following steps 8 - 17 of the standard installation procedure.

3.8

VALVE, SPADE OR BLIND REMOVAL,

INSTALLATION AND OPERATION

The Secure-Grip hydraulic tools are also ideal for the removal and insertion of blinds, spades and valves. Equalizer International can supply a short collet holder kit that will increase the relative stroke of the tool.

TOOL	CONFIGURATION	C ₁ (Closed)	C ₂ (Open)
SG13TE	Standard Tool	0 mm (0")	115mm (4.5")
	Collet holder kits to accommodate	30mm (1.18")	225mm (8.85")
SG15TE	Standard Tool	0 mm (0")	100mm (3.9")
	Collet holder kits to accommodate	40mm (1.57")	180mm (7.09")

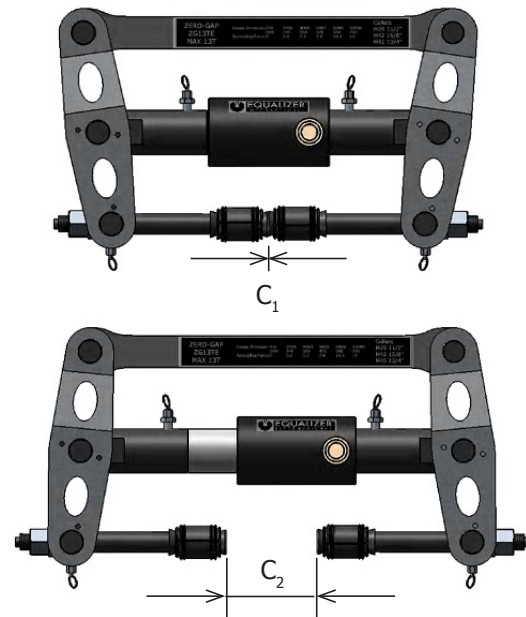

SG13TE COLLET HOLDER KIT(S)

Product Code:
 640100-01 226mm COLLET HOLDER KIT
 640200-01 201mm COLLET HOLDER KIT

ITEM	DESCRIPTION	QTY.
01	COLLET HOLDER	02
02	DRIVE TUBE	02

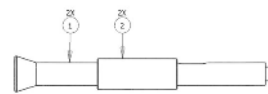

SG15TE COLLET HOLDER KIT(S)

Product Code:
 650100-01 226mm COLLET HOLDER KIT

ITEM	DESCRIPTION	QTY.
01	COLLET HOLDER	02
02	DRIVE TUBE	02

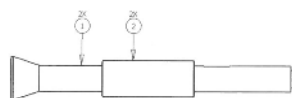

Please refer to section 3.4 for instruction on how to remove the standard collet holder and drive tube. These are then replaced with the collet holders and drive tube with the appropriate collet.



Please follow section 3.5 for instruction on how to attach and activated the secure-grip hydraulic tool.

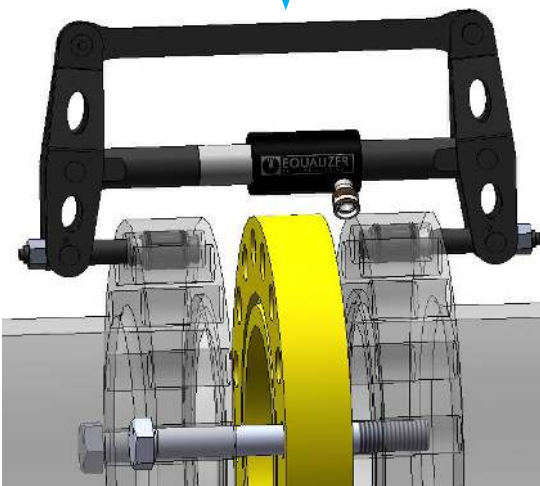
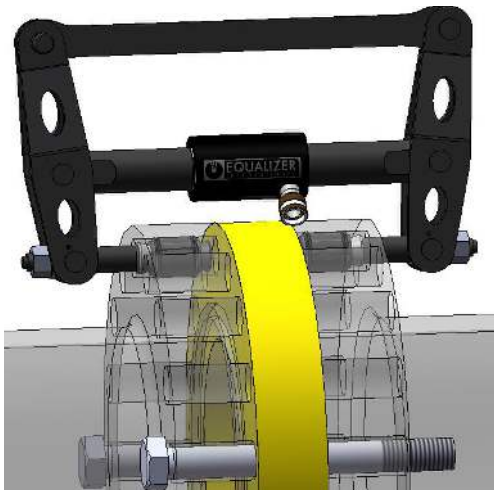

3.9 OVERALL DIMENSIONS

TOOL DIMENSIONS CLOSED



TOOL DIMENSIONS OPEN

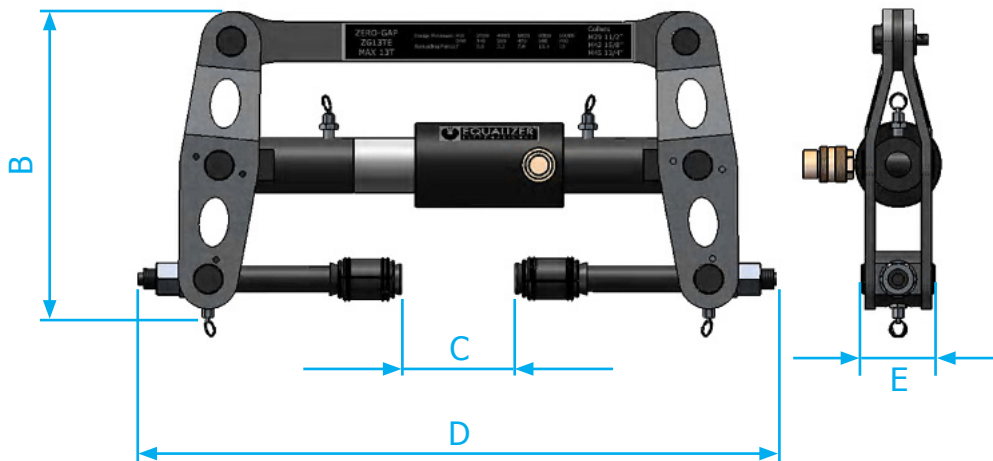

TOOL	A	B	C	D	E	TOOL WEIGHT	KIT WEIGHT
SG13TE	516mm (20.3")	314mm (12.4")	115mm (4.5")	630mm (24.8")	72mm (2.9")	21.5kg (47.3lbs)	40.5kg (89.2lbs)
SG15TE	600mm (23.6")	380mm (15.0")	100mm (3.9")	720mm (28.4")	80mm (3.2")	26kg (57.3lbs)	45kg (99.2lbs)

4.

TOOL MAINTENANCE

4.1 INSPECTION

On return from each job and before allocation against subsequent work the completeness of the Equalizer Secure-Grip hydraulic tool kits must be established and items examined to ensure that they are serviceable.

At regular intervals and specifically after exposure to salt water Secure-Grip hydraulic tools should be dismantled and lubricated as follows:

4.2 DISASSEMBLY

Lay the tool on a bench or flat surface.



Remove the cantilever pin and remove the collet union, actuator connector and cantilever retaining rings. Care should be taken not to over stretch the retaining rings during removal or replacement.

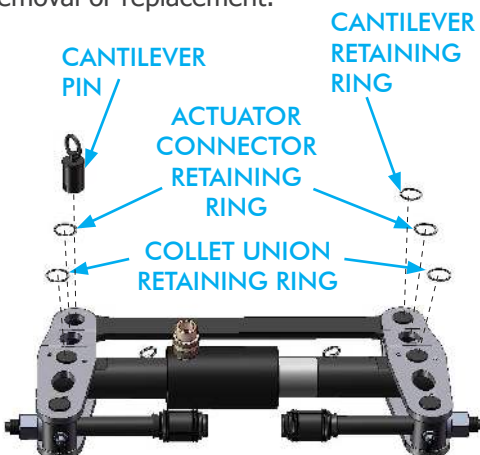

Lift the top leg on both sides from the tool.

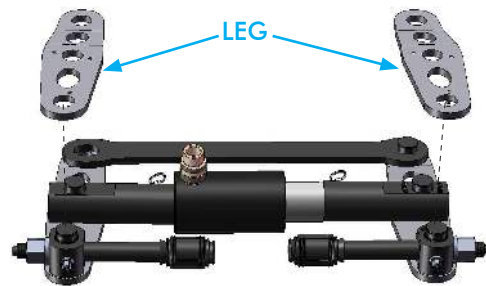

Lift the actuator assembly and the cantilever from the tool.

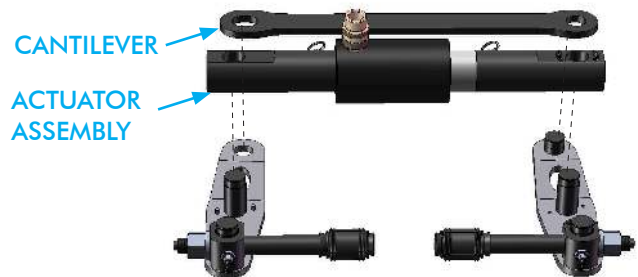

4.3 SERVICING

The exposed parts of the tool can now be cleaned and lubricated.

Care should be taken to ensure the centring springs do not jump out of their recess.



It is recommended that the tool is wiped down with a clean rag and WD40 or similar cleaning fluid to remove any dirt or grit and then liberally greased with a high load bearing grease (Rocol sapphire high load 2 or similar) in the areas shown

The tool can now be reassembled by reversing the dismantling procedure.

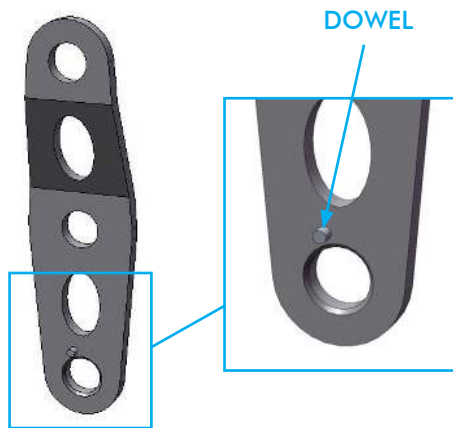

Care should be taken to ensure the dowel protruding from the right hand leg of the tool is engaged between the two centering springs

Once the tool is rebuilt, flip the tool over and repeat the above procedure with the other side of the tool.



If the actuator requires maintenance please refer to an authorised Equalizer distributor

4.4

STORAGE & TRANSPORTATION

Equalizer tools should be stored in a cool dry place. Tools should always be cleaned, serviced and lubricated prior to storage. Ensure that tools are stored in their designated packing cases.

4.5

LONG-TERM STORAGE - MAINTENANCE PLAN

1. Rub components down with a dry cloth to remove moisture.
2. Coat EVERY surface and contact point with a corrosion inhibitor. Where necessary, coat inside and outside of component
3. Nuts and threads must also be coated with a corrosion inhibitor.
4. Once surfaces have been coated, seal individual components in clear plastic bags or clear vacuum bags or clear shrink wrap.
NOTE: bags/shrink wrap must be clear for visibility. Take care when using shrink wrap that the tool is/ components are still easy to see.
5. Remove all or, where not vacuum sealed, as much air from bags as possible.
6. Once bags have been closed and sealed DO NOT re-open. Any visual inspections must be done with closed and sealed bags. If bags are opened the components will have to be dried, re-coated and re-sealed in bags/shrink wrap.
7. Replace silica gel (100g) EVERY TIME the case is opened.
NOTE: depending on moisture content of air, silica gel should be changed weekly.
8. Visually inspect kits after 30-days and every 30-days thereafter. Remember to replace silica gel before closing case.

5.

SG13TE

5.1

SG13TE TOOL CAPABILITIES

SPREADING FORCE = 13 T (130 kN) per tool

It is recommended that tools are used in pairs giving
2 x 13 T = 26 T (260 kN)

If using the Equalizer HP550S Hand Pump (or if a hydraulic pressure gauge is fitted), the spreading force per tool can be determined by taking a reading from the gauge. Gauge pressures will produce spreading forces as set out below.

Pressure		Spreading force	
Bar	psi	T	kN
138	2000	2.6	26
276	4000	5.2	52
414	6000	7.8	78
552	8000	10.4	104
690	10,000	13	130

SPREADING DISTANCE: 0 - 115mm (0 - 4.53")

Hydraulic oil grade: 15 centistokes(cSt) @ 40°C tested by ASTM D 445

5.2

SG13TE KIT CONTENTS

Product Code: SG13TESTD

- 1 x SG13TE Tool c/w Hydraulic Cylinder
- 1 x 10,000 psi (700 bar) HP550S Sealed Hand Pump with Gauge
- 1 x 10,000 psi (700 bar) Hydraulic Hose, 2m (78.75")
- 1 x 150 mm (6") Vernier Calliper
- 1 x 1/2" Square Drive Flexible Handle
- 1 x 30 mm (1 1/8") Drive Socket
- 1 x Safety Block
- 2 x M39 (1 1/2") Collets
- 2 x M42 (1 5/8") Collets
- 2 x M45 (1 3/4") Collets
- 1 x Instruction Manual
- 1 x Carry-Case with Protective Foam Inserts



Carry Case Dimensions:

890 mm x 570 mm x 165 mm (35.0" x 22.4" x 6.5")

Gross Kit Weight: 40.5kg (89.2lbs)

Tool only weight: 21.5kg (47.3lbs)

6.

SG15TE

6.1

SG15TE TOOL CAPABILITIES

SPREADING FORCE = 15 T (150 kN) per tool

It is recommended that tools are used in pairs giving 2 x 15 = 30 T (300 kN)

If using the Equalizer HP550S Hand Pump (or if a hydraulic pressure gauge is fitted), the spreading force per tool can be determined by taking a reading from the gauge. Gauge pressures will produce spreading forces as set out below.

Pressure		Spreading force	
Bar	psi	T	kN
138	2000	3	30
276	4000	6	60
414	6000	9	90
552	8000	12	120
690	10,000	15	150

SPREADING DISTANCE: 0 - 100mm (0 - 3.94")

Hydraulic oil grade: 15 centistokes(cSt) @ 40°C tested by ASTM D 445

6.2

SG15TE KIT CONTENTS

Product Code: SG15TESTD

- 1 x SG15TE Tool c/w Hydraulic Cylinder
- 1 x 10,000 psi (700 bar) HP550S Sealed Hand Pump with Gauge
- 1 x 10,000 psi (700 bar) Hydraulic Hose, 2m (78.75")
- 1 x 300 mm (12") Vernier Calliper
- 1 x 1/2" Square Drive Flexible Handle
- 1 x 36 mm Drive Socket
- 1 x Safety Block
- 2 x M48 (1 7/8") Collets
- 2 x M52 (2") Collets
- 2 x M56 (2 1/4") Collets
- 1 x Instruction Manual
- 1 x Carry-Case with Protective Foam Inserts



Carry-Case Dimensions:

890 mm x 570 mm x 165 mm (35.0" x 22.4" x 6.5")

Gross Kit Weight: 45kg (99.2lbs)

Tool only weight: 26kg (57.3lbs)

7.

TROUBLESHOOTING

7.1

SG13TE/SG15TE TROUBLESHOOTING

HOSES ARE CONNECTED AND THE TOOL ADVANCES WITH MAXIMUM PRESSURE ON THE PUMP HANDLE BUT THE JOINT WILL NOT SPREAD

POSSIBLE CAUSE:

The pressure required to spread the joint is greater than that of the two tools you are using

RECOMMENDED ACTION:

Add another one or two tools and distribute them equally around the joint (120° apart with 3 tools and 90° apart with 4 tools) and try again.

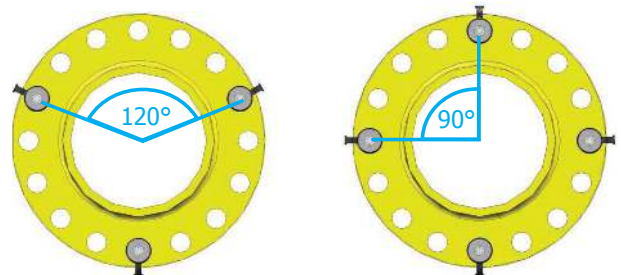

ONE COLLET IS JAMMED IN A BOLT HOLE.

POSSIBLE CAUSE:

A collet which is too small or large has been selected, or the collet has been inserted into a damaged or non-round bolt hole.

RECOMMENDED ACTION:

Removal can be achieved as follows:

1. Pull the collet spring plunger ring out, and remove the rest of the tool, leaving the collet head assembly in the bolt hole
2. Unscrew the drive nut and remove the drive cone and collet cone
3. Screw the drive nut back onto the collet holder until it is 1-2mm off the end
4. Using a hammer and a suitable drift, move the collet holder until the drive nut is against the flange
5. Remove the drive nut and push the collet holder through the flange and out of the other end of the bolt-hole
6. Drive the collet out using the collet holder

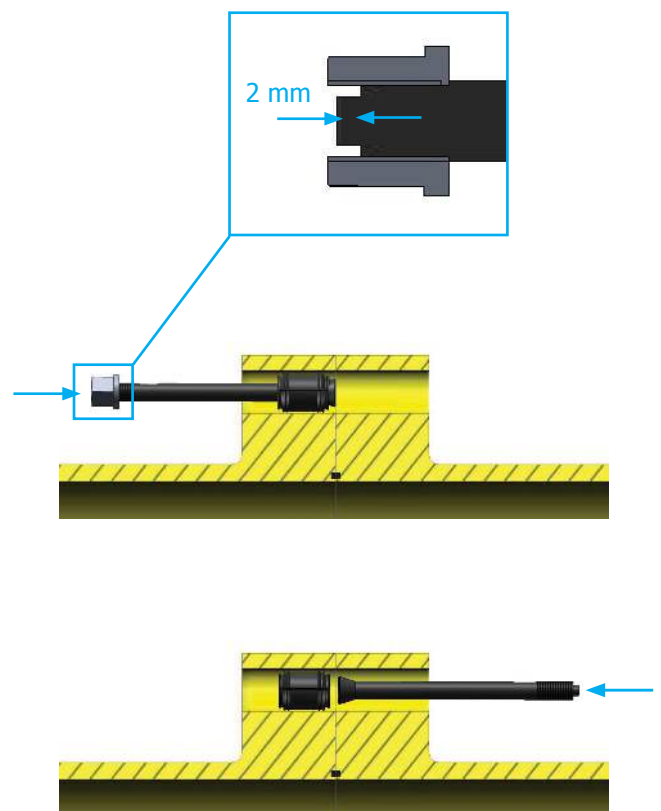

A PAIR OF COLLETS ARE JAMMED IN A BOLT HOLE.

POSSIBLE CAUSE:

A collet which is too small or large has been selected, or the collet has been inserted into a damaged or non-round bolt hole.

RECOMMENDED ACTION:

The flange must be spread before removal can be attempted. This can be done using another pair of Secure Grip tools, or another method if available. Removal can be achieved as follows:

1. On both sides, pull the collet spring plunger ring out, and remove the rest of the tool, leaving the collet head assemblies in the bolt-hole
2. On both sides, unscrew the drive nut and remove the drive cone and collet cone
3. On the left-hand side, screw the drive nut back onto the collet holder until it is 1-2mm off the end
4. Using a hammer and a suitable drift, move the collet holder until it is possible to cut off the tapered end of the collet holder
5. Cut off the tapered end with a hack saw or other cutting tool
6. Withdraw the collet holder from the bolt-hole
7. Using a hammer and a suitable drift, move the collet holder on the right-hand side up to the left-hand side collet and drive it out
8. Drive the right-hand side collet out using the collet holder

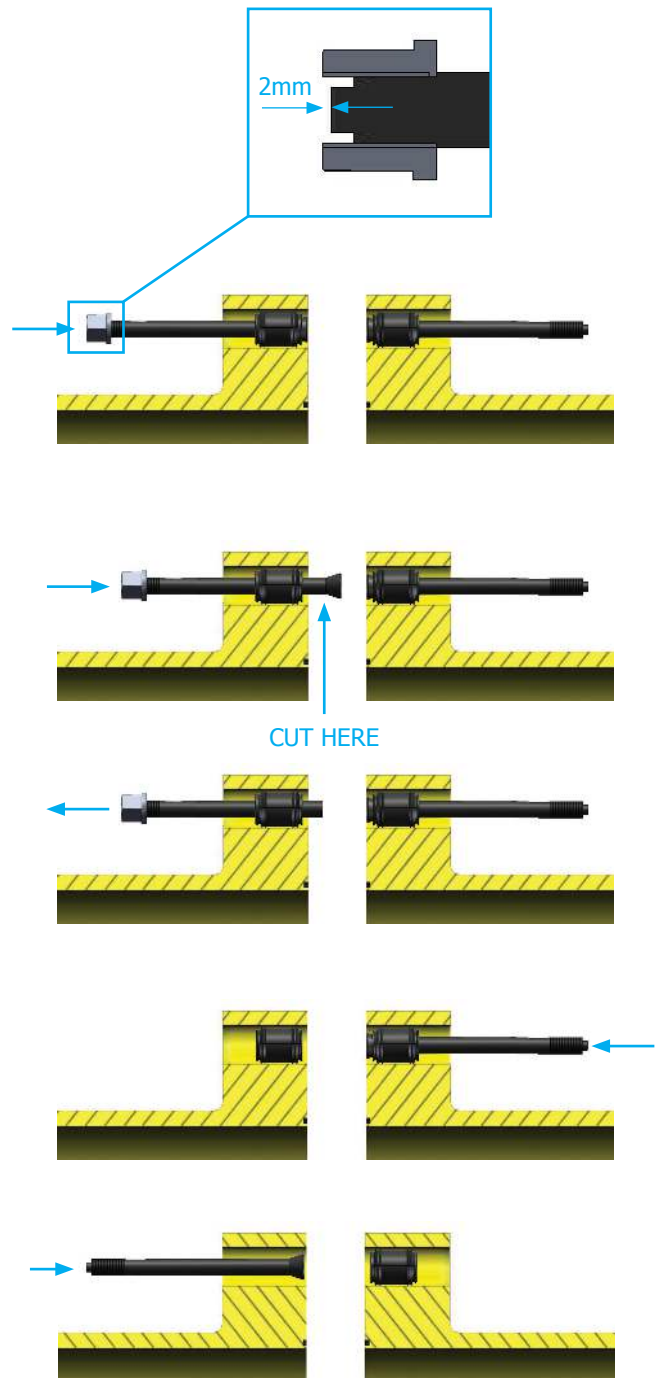

HOSES ARE CONNECTED BUT THE TOOL DOES NOT ADVANCE. THE PRESSURE ON THE PUMP HANDLE IS MINIMAL

POSSIBLE CAUSE:

The release valve is in the retract (open) position.

RECOMMENDED ACTION:

Close the release valve .



HOSES ARE CONNECTED AND THE PUMP QUICKLY REACHES MAXIMUM PRESSURE BUT THE TOOL HAS NOT ADVANCED

POSSIBLE CAUSE:

One or more of the connectors are not fully tightened and the hydraulic oil cannot pass through from the pump to the cylinder.

RECOMMENDED ACTION:

Check all connectors are fully tightened and the release valve is in the fully closed position.

HOSES ARE CONNECTED AND THE TOOL ADVANCES BUT THERE IS MINIMAL PRESSURE ON THE PUMP HANDLE; THE HANDLE IS RISING BACK OF ITS OWN ACCORD

POSSIBLE CAUSE:

There is dirt or a damaged valve seat within the pump unit.

RECOMMENDED ACTION:

The pump should be sent to an authorised Equalizer distributor for repair.

HOSES ARE CONNECTED AND THE TOOL ADVANCES AS THE PUMP IS PRIMED BUT THE PRESSURE ON THE PUMP HANDLE IS MINIMAL AND FEELS SPONGY

POSSIBLE CAUSE:

Air could be present in the hydraulic system.

RECOMMENDED ACTION:

Follow the airlock removal procedure:

1. Connect the hand pump to the tool with the hydraulic hose.
2. Close the release valve on the pump, and prime the pump until the hydraulic cylinder is fully extended and a small pressure is achieved
3. With the hand pump held above the tool and the tool in an upright position, open the release valve causing any air that is within the system to be forced up through the pump and vented into the oil reservoir
4. Repeat steps 1 - 3 three or four times to ensure that all air is removed from the system and the tool will reach full working pressure
5. Disconnect the hand pump from the hydraulic hose, grip the baseplate of the hand pump body in a vice with the pump body vertical and the main handle at the top
6. Remove the four nuts holding the main handle and lift off
7. Grip the refilling plug with pliers and extract it by pulling and twisting simultaneously. Ensure the reservoir body is held down when removing the refilling plug as pulling up on the reservoir body will release the bladder within, and oil will spill out.
8. Fill the reservoir to the top with a good quality hydraulic oil of the grade 15 cSt
9. Reinsert the refilling plug, wipe away any oil, and reassemble by reversing the disassembly process

AIRLOCK REMOVAL PROCEDURE:

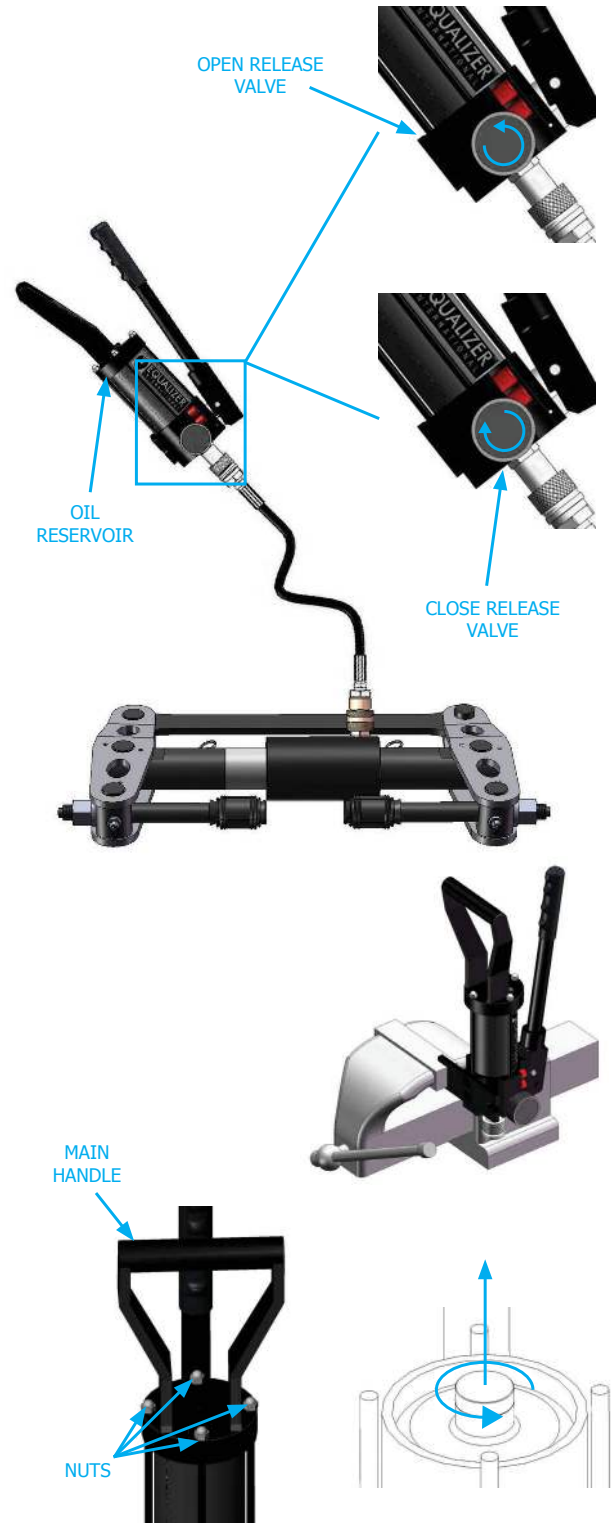

8.

SECURE GRIP TOOL RANGE OF APPLICATION

Use the charts on the following pages to determine which Secure-Grip tool (and which collet size) is suitable for a particular flange.

The charts are categorised as per flange type.

Collet identification	Tool type	Operation type	SWL (ton)	Min. bolt-hole diameter	Max. bolt-hole diameter
M16 5/8"	SG4TM	manual	4	17.5	19.5
M20 3/4"	SG4TM	manual	4	20.5	23
M24 7/8"	SG6TM	manual	6	24	26.5
M27 1"	SG6TM	manual	6	27.5	30
M30 1 1/8"	SG11TM	manual	11	30	33
M33 1 1/4"	SG11TM	manual	11	32	36
M36 1 3/8"	SG11TM	manual	11	35	39
M39 1 1/2"	SG13TE	hydraulic	13	38	42
M42 1 5/8"	SG13TE	hydraulic	13	41	45
M45 1 3/4"	SG13TE	hydraulic	13	44	49
M48 1 7/8"	SG15TE	hydraulic	15	47.5	52
M52 2"	SG15TE	hydraulic	15	50.5	56
M56 2 1/4"	SG15TE	hydraulic	15	55.5	62
M60	SG18TE	in-line hydraulic	18	59.5	63
M64 2 1/2"	SG18TE	in-line hydraulic	18	63	69
M70 2 3/4"	SG18TE	in-line hydraulic	18	69	75
M76 3"	SG25TE	in-line hydraulic	25	75	81
M80 3 1/4"	SG25TE	in-line hydraulic	25	79	86
M84	SG25TE	in-line hydraulic	25	83	88
M90 3 1/2"	SG25TE	in-line hydraulic	25	88	94
M95 3 3/4"	SG25TE	in-line hydraulic	25	94	101
M100 4"	SG25TE	in-line hydraulic	25	99	107

SPO		→	see page 26
ANSI	compact	→	see page 27
	orifice	→	see page 27
	reducing	→	see page 28
DIN	blind	→	see page 29
	threaded	→	see page 29
	weldneck	→	see page 30
	flat	→	see page 30
	lapped	→	see page 30
ASME	series A weld neck	→	see page 31
	series A lapped	→	see page 32
	series A socket welded	→	see page 32
	series B weld neck and blind	→	see page 32
API	6B weld neck	→	see page 33
	6B blind and threaded	→	see page 33
	6BX weld neck	→	see page 33
	6BX blind and test	→	see page 33
BS		→	see page 34

SPO FLANGES

Nominal pipe size	Class													
	150		300		600		900		1500		2500		4500i	
	collet	tool	collet	tool	collet	tool	collet	tool	collet	tool	collet	tool	collet	tool
1 1/2"													M16 5/8"	SG4TM
2"													M16 5/8"	SG4TM
2 1/2"													M20 3/4"	SG4TM
3"													M16 5/8"	SG4TM
4"					M16 5/8"	SG4TM	M16 5/8"	SG4TM	M20 3/4"	SG4TM	M27 1"	SG6TM	M24 7/8"	SG6TM
5"					M16 5/8"	SG4TM	M16 5/8"	SG4TM	M24 7/8"	SG6TM	M27 1"	SG6TM	M30 1 1/8"	SG11TM
6"					M16 5/8"	SG4TM	M16 5/8"	SG4TM	M27 1"	SG6TM	M30 1 1/8"	SG11TM	M33 1 1/4"	SG11TM
8"			M16 5/8"	SG4TM	M16 5/8"	SG4TM	M20 3/4"	SG4TM	M27 1"	SG6TM	M36 1 3/8"	SG11TM	M39 1 1/2"	SG13TE
10"			M16 5/8"	SG4TM	M20 3/4"	SG4TM	M24 7/8"	SG6TM	M33 1 1/4"	SG11TM	M39 1 1/2"	SG13TE	M48 1 7/8"	SG15TE
12"			M16 5/8"	SG4TM	M24 7/8"	SG6TM	M27 1"	SG6TM	M33 1 1/4"	SG11TM	M45 1 3/4"	SG13TE	M48 1 7/8"	SG15TE
14"			M16 5/8"	SG4TM	M24 7/8"	SG6TM	M27 1"	SG6TM	M36 1 3/8"	SG11TM	M48 1 7/8"	SG15TE	M52 2"	SG15TE
16"	M16 5/8"	SG4TM	M20 3/4"	SG4TM	M27 1"	SG6TM	M30 1 1/8"	SG11TM	M39 1 1/2"	SG13TE	M60	SG18TE	M60	SG18TE
18"	M16 5/8"	SG4TM	M20 3/4"	SG4TM	M30 1 1/8"	SG11TM	M33 1 1/4"	SG11TM	M45 1 3/4"	SG13TE	M60	SG18TE	M64 2 1/2"	SG18TE
20"	M16 5/8"	SG4TM	M24 7/8"	SG6TM	M30 1 1/8"	SG11TM	M36 1 3/8"	SG11TM	M48 1 7/8"	SG15TE	M64 2 1/2"	SG18TE	M84	SG25TE
22"	M16 5/8"	SG4TM	M24 7/8"	SG6TM	M33 1 1/4"	SG11TM	M39 1 1/2"	SG13TE	M52 2"	SG15TE	M76 3"	SG25TE	M90 3 1/2"	SG25TE
24"	M20 3/4"	SG4TM	M27 1"	SG6TM	M33 1 1/4"	SG11TM	M42 1 5/8"	SG13TE	M60	SG18TE	M84	SG25TE	M100 4"	SG25TE
26"	M20 3/4"	SG4TM	M27 1"	SG6TM	M33 1 1/4"	SG11TM	M45 1 3/4"	SG13TE	M60	SG18TE				
28"	M20 3/4"	SG4TM	M27 1"	SG6TM	M36 1 3/8"	SG11TM	M45 1 3/4"	SG13TE	M60	SG18TE				
30"	M20 3/4"	SG4TM	M30 1 1/8"	SG11TM	M36 1 3/8"	SG11TM	M48 1 7/8"	SG15TE	M64 2 1/2"	SG18TE				
32"	M20 3/4"	SG4TM	M30 1 1/8"	SG11TM	M39 1 1/2"	SG13TE	M52 2"	SG15TE	M64 2 1/2"	SG18TE				
34"	M20 3/4"	SG4TM	M33 1 1/4"	SG11TM	M39 1 1/2"	SG13TE	M60	SG18TE	M70 2 3/4"	SG18TE				
36"	M24 7/8"	SG6TM	M33 1 1/4"	SG11TM	M39 1 1/2"	SG13TE	M60	SG18TE	M84	SG25TE				
38"	M24 7/8"	SG6TM	M33 1 1/4"	SG11TM	M39 1 1/2"	SG13TE	M64 2 1/2"	SG18TE	M90 3 1/2"	SG25TE				
40"	M24 7/8"	SG6TM	M33 1 1/4"	SG11TM	M39 1 1/2"	SG13TE	M64 2 1/2"	SG18TE	M84	SG25TE				
42"	M24 7/8"	SG6TM	M36 1 3/8"	SG11TM	M48 1 7/8"	SG15TE	M64 2 1/2"	SG18TE	M95 3 3/4"	SG25TE				
44"	M24 7/8"	SG6TM	M36 1 3/8"	SG11TM	M48 1 7/8"	SG15TE	M64 2 1/2"	SG18TE	M95 3 3/4"	SG25TE				
46"	M24 7/8"	SG6TM	M39 1 1/2"	SG13TE	M48 1 7/8"	SG15TE	M70 2 3/4"	SG18TE	M95 3 3/4"	SG25TE				
48"	M24 7/8"	SG6TM	M39 1 1/2"	SG13TE	M48 1 7/8"	SG15TE	M76 3"	SG25TE	M95 3 3/4"	SG25TE				

ANSI COMPACT

Nominal pipe size	Class									
	300		600		900		1500		2500	
	collet	tool	collet	tool	collet	tool	collet	tool	collet	tool
1"	no flange		no flange		no flange		no flange		no flange	
1 1/2"										
2"									M16 5/8"	SG4TM
2 1/2"	M16 5/8"	SG4TM	M16 5/8"	SG4TM	M16 5/8"	SG4TM	M16 5/8"	SG4TM	M24 7/8"	SG6TM
3"	M16 5/8"	SG4TM	M16 5/8"	SG4TM	M16 5/8"	SG4TM	M16 5/8"	SG4TM	M16 5/8"	SG4TM
4"	M20 3/4"	SG4TM	M20 3/4"	SG4TM	M20 3/4"	SG4TM	M20 3/4"	SG4TM	M20 3/4"	SG4TM
5"	M20 3/4"	SG4TM	M20 3/4"	SG4TM	M20 3/4"	SG4TM	M20 3/4"	SG4TM	M27 1"	SG6TM
6"	M20 3/4"	SG4TM	M20 3/4"	SG4TM	M20 3/4"	SG4TM	M24 7/8"	SG6TM	M30 1 1/8"	SG11TM
8"	M20 3/4"	SG4TM	M20 3/4"	SG4TM	M20 3/4"	SG4TM	M27 1"	SG6TM	M36 1 3/8"	SG11TM
10"	M20 3/4"	SG4TM	M20 3/4"	SG4TM	M27 1"	SG6TM	M30 1 1/8"	SG11TM	M45 1 3/4"	SG13TE
12"	M20 3/4"	SG4TM	M24 7/8"	SG6TM	M30 1 1/8"	SG11TM	M36 1 3/8"	SG11TM	M52 2"	SG15TE
14"	M20 3/4"	SG4TM	M27 1"	SG6TM	M33 1 1/4"	SG11TM	M36 1 3/8"	SG11TM	M45 1 3/4"	SG13TE
16"	M20 3/4"	SG4TM	M30 1 1/8"	SG11TM	M36 1 3/8"	SG11TM	M42 1 5/8"	SG13TE	M52 2"	SG15TE
18"	M24 7/8"	SG6TM	M33 1 1/4"	SG11TM	M36 1 3/8"	SG11TM	M45 1 3/4"	SG13TE	M56 2 1/4"	SG15TE
20"	M30 1 1/8"	SG11TM	M36 1 3/8"	SG11TM	M39 1 1/2"	SG13TE	M52 2"	SG15TE	M64 2 1/2"	SG18TE
24"	M30 1 1/8"	SG11TM	M39 1 1/2"	SG13TE	M45 1 3/4"	SG13TE	M56 2 1/4"	SG15TE	M64 2 1/2"	SG18TE
30"	M27 1"	SG6TM	M42 1 5/8"	SG13TE	M56 2 1/4"	SG15TE	M70 2 3/4"	SG18TE		
36"	M30 1 1/8"	SG11TM	M45 1 3/4"	SG13TE	M56 2 1/4"	SG15TE	M76 3"	SG25TE		
40"	M30 1 1/8"	SG11TM	M52 2"	SG15TE	M64 2 1/2"	SG18TE	M84	SG25TE		

ANSI ORIFICE

Nominal pipe size	Class											
	300		400		600		900		1500		2500	
	collet	tool	collet	tool	collet	tool	collet	tool	collet	tool		
1"	M16 5/8"	SG4TM	M16 5/8"	SG4TM	M16 5/8"	SG4TM	M24 7/8"	SG6TM	M24 7/8"	SG6TM	M24 7/8"	SG6TM
1 1/2"	M20 3/4"	SG4TM	M20 3/4"	SG4TM	M20 3/4"	SG4TM	M27 1"	SG6TM	M27 1"	SG6TM	M30 1 1/8"	SG11TM
2"	M16 5/8"	SG4TM	M16 5/8"	SG4TM	M16 5/8"	SG4TM	M24 7/8"	SG6TM	M24 7/8"	SG6TM	M27 1"	SG6TM
2 1/2"	M20 3/4"	SG4TM	M20 3/4"	SG4TM	M20 3/4"	SG4TM	M27 1"	SG6TM	M27 1"	SG6TM	M30 1 1/8"	SG11TM
3"	M20 3/4"	SG4TM	M20 3/4"	SG4TM	M20 3/4"	SG4TM	M24 7/8"	SG6TM	M30 1 1/8"	SG11TM	M33 1 1/4"	SG11TM
4"	M20 3/4"	SG4TM	M24 7/8"	SG6TM	M24 7/8"	SG6TM	M30 1 1/8"	SG11TM	M33 1 1/4"	SG11TM	M39 1 1/2"	SG13TE
6"	M20 3/4"	SG4TM	M24 7/8"	SG6TM	M27 1"	SG6TM	M30 1 1/8"	SG11TM	M36 1 3/8"	SG11TM	M52 2"	SG15TE
8"	M24 7/8"	SG6TM	M27 1"	SG6TM	M30 1 1/8"	SG11TM	M36 1 3/8"	SG11TM	M42 1 5/8"	SG13TE	M52 2"	SG15TE
10"	M27 1"	SG6TM	M30 1 1/8"	SG11TM	M33 1 1/4"	SG11TM	M36 1 3/8"	SG11TM	M48 1 7/8"	SG15TE	M64 2 1/2"	SG18TE
12"	M30 1 1/8"	SG11TM	M33 1 1/4"	SG11TM	M33 1 1/4"	SG11TM	M36 1 3/8"	SG11TM	M52 2"	SG15TE	M70 2 3/4"	SG18TE
14"	M30 1 1/8"	SG11TM	M33 1 1/4"	SG11TM	M36 1 3/8"	SG11TM	M39 1 1/2"	SG13TE	M56 2 1/4"	SG15TE		
16"	M33 1 1/4"	SG11TM	M36 1 3/8"	SG11TM	M39 1 1/2"	SG13TE	M42 1 5/8"	SG13TE	M64 2 1/2"	SG18TE		
18"	M33 1 1/4"	SG11TM	M36 1 3/8"	SG11TM	M42 1 5/8"	SG13TE	M48 1 7/8"	SG15TE	M70 2 3/4"	SG18TE		
20"	M33 1 1/4"	SG11TM	M39 1 1/2"	SG13TE	M42 1 5/8"	SG13TE	M52 2"	SG15TE	M76 3"	SG25TE		
24"	M39 1 1/2"	SG13TE	M45 1 3/4"	SG13TE	M48 1 7/8"	SG15TE	M64 2 1/2"	SG18TE	M90 3 1/2"	SG25TE		

ANSI REDUCING

Nominal pipe size	Class													
	150		300		400		600		900		1500		2500	
	collet	tool	collet	tool	collet	tool	collet	tool	collet	tool	collet	tool	collet	tool
1/2"														
3/4"			M16 5/8"	SG4TM	M16 5/8"	SG4TM	M16 5/8"	SG4TM	M20 3/4"	SG4TM	M20 3/4"	SG4TM	M20 3/4"	SG4TM
1"			M16 5/8"	SG4TM	M16 5/8"	SG4TM	M16 5/8"	SG4TM	M24 7/8"	SG6TM	M24 7/8"	SG6TM	M24 7/8"	SG6TM
1 1/4"			M16 5/8"	SG4TM	M16 5/8"	SG4TM	M16 5/8"	SG4TM	M24 7/8"	SG6TM	M24 7/8"	SG6TM	M27 1"	SG6TM
1 1/2"			M20 3/4"	SG4TM	M20 3/4"	SG4TM	M20 3/4"	SG4TM	M27 1"	SG6TM	M27 1"	SG6TM	M30 1 1/8"	SG11TM
2"	M16 5/8"	SG4TM	M16 5/8"	SG4TM	M16 5/8"	SG4TM	M16 5/8"	SG4TM	M24 7/8"	SG6TM	M24 7/8"	SG6TM	M27 1"	SG6TM
2 1/2"	M16 5/8"	SG4TM	M20 3/4"	SG4TM	M20 3/4"	SG4TM	M20 3/4"	SG4TM	M27 1"	SG6TM	M27 1"	SG6TM	M30 1 1/8"	SG11TM
3"	M16 5/8"	SG4TM	M20 3/4"	SG4TM	M20 3/4"	SG4TM	M20 3/4"	SG4TM	M24 7/8"	SG6TM	M30 1 1/8"	SG11TM	M33 1 1/4"	SG11TM
3 1/2"	M16 5/8"	SG4TM	M20 3/4"	SG4TM	M24 7/8"	SG6TM	M24 7/8"	SG6TM	no flange		no flange		no flange	
4"	M16 5/8"	SG4TM	M20 3/4"	SG4TM	M24 7/8"	SG6TM	M24 7/8"	SG6TM	M30 1 1/8"	SG11TM	M33 1 1/4"	SG11TM	M39 1 1/2"	SG13TE
5"	M20 3/4"	SG4TM	M20 3/4"	SG4TM	M24 7/8"	SG6TM	M27 1"	SG6TM	M33 1 1/4"	SG11TM	M39 1 1/2"	SG13TE	M45 1 3/4"	SG13TE
6"	M20 3/4"	SG4TM	M20 3/4"	SG4TM	M24 7/8"	SG6TM	M27 1"	SG6TM	M30 1 1/8"	SG11TM	M36 1 3/8"	SG11TM	M52 2"	SG15TE
8"	M20 3/4"	SG4TM	M24 7/8"	SG6TM	M27 1"	SG6TM	M30 1 1/8"	SG11TM	M36 1 3/8"	SG11TM	M42 1 5/8"	SG13TE	M52 2"	SG15TE
10"	M24 7/8"	SG6TM	M27 1"	SG6TM	M30 1 1/8"	SG11TM	M33 1 1/4"	SG11TM	M36 1 3/8"	SG11TM	M48 1 7/8"	SG15TE	M64 2 1/2"	SG18TE
12"	M24 7/8"	SG6TM	M30 1 1/8"	SG11TM	M33 1 1/4"	SG11TM	M33 1 1/4"	SG11TM	M36 1 3/8"	SG11TM	M52 2"	SG15TE	M70 2 3/4"	SG18TE
14"	M27 1"	SG6TM	M30 1 1/8"	SG11TM	M33 1 1/4"	SG11TM	M36 1 3/8"	SG11TM	M39 1 1/2"	SG13TE	M56 2 1/4"	SG15TE		
16"	M27 1"	SG6TM	M33 1 1/4"	SG11TM	M36 1 3/8"	SG11TM	M39 1 1/2"	SG13TE	M42 1 5/8"	SG13TE	M64 2 1/2"	SG18TE		
18"	M30 1 1/8"	SG11TM	M33 1 1/4"	SG11TM	M36 1 3/8"	SG11TM	M42 1 5/8"	SG13TE	M48 1 7/8"	SG15TE	M70 2 3/4"	SG18TE		
20"	M30 1 1/8"	SG11TM	M33 1 1/4"	SG11TM	M39 1 1/2"	SG13TE	M42 1 5/8"	SG13TE	M52 2"	SG15TE	M76 3"	SG25TE		
22"	no flange		no flange		no flange		no flange		no flange		no flange			
24"	M33 1 1/4"	SG11TM	M39 1 1/2"	SG13TE	M45 1 3/4"	SG13TE	M48 1 7/8"	SG15TE	M64 2 1/2"	SG18TE	M90 3 1/2"	SG25TE		
26"	M33 1 1/4"	SG11TM	M42 1 5/8"	SG13TE	M42 1 5/8"	SG13TE	M48 1 7/8"	SG15TE	M70 2 3/4"	SG18TE				
28"	M33 1 1/4"	SG11TM	M42 1 5/8"	SG13TE	M42 1 5/8"	SG13TE	M52 2"	SG15TE	M76 3"	SG25TE				
30"	M33 1 1/4"	SG11TM	M45 1 3/4"	SG13TE	M45 1 3/4"	SG13TE	M56 2 1/4"	SG15TE	M76 3"	SG25TE				
32"	M39 1 1/2"	SG13TE	M48 1 7/8"	SG15TE	M48 1 7/8"	SG15TE	M56 2 1/4"	SG15TE	M84	SG25TE				
34"	M39 1 1/2"	SG13TE	M48 1 7/8"	SG15TE	M48 1 7/8"	SG15TE	M56 2 1/4"	SG15TE	M90 3 1/2"	SG25TE				
36"	M39 1 1/2"	SG13TE	M52 2"	SG15TE	M52 2"	SG15TE	M56 2 1/4"	SG15TE	M90 3 1/2"	SG25TE				
38"	M39 1 1/2"	SG13TE	M39 1 1/2"	SG13TE	M39 1 1/2"	SG13TE	M56 2 1/4"	SG15TE	M90 3 1/2"	SG25TE				
40"	M39 1 1/2"	SG13TE	M42 1 5/8"	SG13TE	M42 1 5/8"	SG13TE	M56 2 1/4"	SG15TE	M90 3 1/2"	SG25TE				
42"	M39 1 1/2"	SG13TE	M42 1 5/8"	SG13TE	M42 1 5/8"	SG13TE	M56 2 1/4"	SG15TE	M90 3 1/2"	SG25TE				
44"	M39 1 1/2"	SG13TE	M45 1 3/4"	SG13TE	M45 1 3/4"	SG13TE	M56 2 1/4"	SG15TE	M95 3 3/4"	SG25TE				
46"	M39 1 1/2"	SG13TE	M48 1 7/8"	SG15TE	M48 1 7/8"	SG15TE	M56 2 1/4"	SG15TE	M100 4"	SG25TE				
48"	M39 1 1/2"	SG13TE	M48 1 7/8"	SG15TE	M48 1 7/8"	SG15TE	M70 2 3/4"	SG18TE	M100 4"	SG25TE				

DIN BLIND

Nominal pipe size	Class									
	PN16		PN25		PN40		PN64		PN100	
	collet	tool	collet	tool	collet	tool	collet	tool	collet	tool
3/4"							no flange		no flange	
1"							M16 5/8"	SG4TM	M16 5/8"	SG4TM
1 1/4"	M16 5/8"	SG4TM	M16 5/8"	SG4TM	M16 5/8"	SG4TM	M20 3/4"	SG4TM	M20 3/4"	SG4TM
1 1/2"	M16 5/8"	SG4TM	M16 5/8"	SG4TM	M16 5/8"	SG4TM	M20 3/4"	SG4TM	M20 3/4"	SG4TM
2"	M16 5/8"	SG4TM	M16 5/8"	SG4TM	M16 5/8"	SG4TM	M20 3/4"	SG4TM	M24 7/8"	SG6TM
2 1/2"	M16 5/8"	SG4TM	M16 5/8"	SG4TM	M16 5/8"	SG4TM	M20 3/4"	SG4TM	M24 7/8"	SG6TM
3"	M16 5/8"	SG4TM	M16 5/8"	SG4TM	M16 5/8"	SG4TM	M20 3/4"	SG4TM	M24 7/8"	SG6TM
4"	M16 5/8"	SG4TM	M20 3/4"	SG4TM	M20 3/4"	SG4TM	M24 7/8"	SG6TM	M27 1"	SG6TM
5"	M16 5/8"	SG4TM	M24 7/8"	SG6TM	M24 7/8"	SG6TM	M27 1"	SG6TM	M30 1 1/8"	SG11TM
6"	M20 3/4"	SG4TM	M24 7/8"	SG6TM	M24 7/8"	SG6TM	M30 1 1/8"	SG11TM	M30 1 1/8"	SG11TM
7"	M20 3/4"	SG4TM	M24 7/8"	SG6TM	M27 1"	SG6TM	M30 1 1/8"	SG11TM	M30 1 1/8"	SG11TM
8"	M20 3/4"	SG4TM	M24 7/8"	SG6TM	M27 1"	SG6TM	M33 1 1/4"	SG11TM	M33 1 1/4"	SG11TM
10"	M24 7/8"	SG6TM	M27 1"	SG6TM	M30 1 1/8"	SG11TM	M33 1 1/4"	SG11TM	M36 1 3/8"	SG11TM
12"	M24 7/8"	SG6TM	M27 1"	SG6TM	M30 1 1/8"	SG11TM	M33 1 1/4"	SG11TM	M39 1 1/2"	SG13TE
14"	M24 7/8"	SG6TM	M30 1 1/8"	SG11TM	M33 1 1/4"	SG11TM	M36 1 3/8"	SG11TM	M45 1 3/4"	SG13TE
16"	M27 1"	SG6TM	M33 1 1/4"	SG11TM	M36 1 3/8"	SG11TM	M39 1 1/2"	SG13TE		
20"	M30 1 1/8"	SG11TM	M33 1 1/4"	SG11TM	M39 1 1/2"	SG13TE				

DIN THREADED

Nominal pipe size	Class									
	PN16		PN25		PN40		PN64		PN100	
	collet	tool	collet	tool	collet	tool	collet	tool	collet	tool
3/4"									M16 5/8"	SG4TM
1"									M16 5/8"	SG4TM
1 1/4"	M16 5/8"	SG4TM	M16 5/8"	SG4TM	M16 5/8"	SG4TM	M16 5/8"	SG4TM	M20 3/4"	SG4TM
1 1/2"	M16 5/8"	SG4TM	M16 5/8"	SG4TM	M16 5/8"	SG4TM	M16 5/8"	SG4TM	M20 3/4"	SG4TM
2"	M16 5/8"	SG4TM	M16 5/8"	SG4TM	M16 5/8"	SG4TM	M20 3/4"	SG4TM	M24 7/8"	SG6TM
2 1/2"	M16 5/8"	SG4TM	M16 5/8"	SG4TM	M16 5/8"	SG4TM	M20 3/4"	SG4TM	M24 7/8"	SG6TM
3"	M16 5/8"	SG4TM	M16 5/8"	SG4TM	M16 5/8"	SG4TM	M20 3/4"	SG4TM	M24 7/8"	SG6TM
4"	M16 5/8"	SG4TM	M20 3/4"	SG4TM	M20 3/4"	SG4TM	M24 7/8"	SG6TM	M27 1"	SG6TM
5"	M16 5/8"	SG4TM	M24 7/8"	SG6TM	M24 7/8"	SG6TM	M24 7/8"	SG6TM	M30 1 1/8"	SG11TM
6"	M16 5/8"	SG4TM	M24 7/8"	SG6TM	M24 7/8"	SG6TM	M30 1 1/8"	SG11TM	M30 1 1/8"	SG11TM

DIN WELDNECK

Nominal pipe size	Class											
	PN16		PN25		PN40		PN64		PN100		PN160	
	collet	tool	collet	tool	collet	tool	collet	tool	collet	tool	collet	tool
1"							M16 5/8"	SG4TM	M16 5/8"	SG4TM	M16 5/8"	SG4TM
1 1/4"	M16 5/8"	SG4TM	M16 5/8"	SG4TM	M16 5/8"	SG4TM						
1 1/2"	M16 5/8"	SG4TM	M16 5/8"	SG4TM	M16 5/8"	SG4TM	M20 3/4"	SG4TM	M20 3/4"	SG4TM	M20 3/4"	SG4TM
2"	M16 5/8"	SG4TM	M16 5/8"	SG4TM	M16 5/8"	SG4TM	M20 3/4"	SG4TM	M24 7/8"	SG6TM	M24 7/8"	SG6TM
2 1/2"	M16 5/8"	SG4TM	M16 5/8"	SG4TM	M16 5/8"	SG4TM	M20 3/4"	SG4TM	M24 7/8"	SG6TM	M24 7/8"	SG6TM
3"	M16 5/8"	SG4TM	M16 5/8"	SG4TM	M16 5/8"	SG4TM	M20 3/4"	SG4TM	M24 7/8"	SG6TM	M24 7/8"	SG6TM
4"	M16 5/8"	SG4TM	M16 5/8"	SG4TM	M16 5/8"	SG4TM	M24 7/8"	SG6TM	M27 1"	SG6TM	M27 1"	SG6TM
5"	M16 5/8"	SG4TM	M16 5/8"	SG4TM	M16 5/8"	SG4TM	M27 1"	SG6TM	M30 1 1/8"	SG11TM	M30 1 1/8"	SG11TM
6"	M20 3/4"	SG4TM	M20 3/4"	SG4TM	M20 3/4"	SG4TM	M30 1 1/8"	SG11TM	M30 1 1/8"	SG11TM	M30 1 1/8"	SG11TM
7"	M20 3/4"	SG4TM	M24 7/8"	SG6TM	M20 3/4"	SG4TM	M30 1 1/8"	SG11TM	M30 1 1/8"	SG11TM	M33 1 1/4"	SG11TM
8"	M20 3/4"	SG4TM	M24 7/8"	SG6TM	M20 3/4"	SG4TM	M33 1 1/4"	SG11TM	M33 1 1/4"	SG11TM	M33 1 1/4"	SG11TM
10"	M24 7/8"	SG6TM	M27 1"	SG6TM	M24 7/8"	SG6TM	M33 1 1/4"	SG11TM	M36 1 3/8"	SG11TM	M39 1 1/2"	SG13TE
12"	M24 7/8"	SG6TM	M27 1"	SG6TM	M24 7/8"	SG6TM	M33 1 1/4"	SG11TM	M39 1 1/2"	SG13TE	M39 1 1/2"	SG13TE
14"	M24 7/8"	SG6TM	M30 1 1/8"	SG11TM	M24 7/8"	SG6TM	M36 1 3/8"	SG11TM	M45 1 3/4"	SG13TE		
16"	M27 1"	SG6TM	M33 1 1/4"	SG11TM	M27 1"	SG6TM	M39 1 1/2"	SG13TE				
18"	M27 1"	SG6TM	M33 1 1/4"	SG11TM	M27 1"	SG6TM						
20"	M30 1 1/8"	SG11TM	M33 1 1/4"	SG11TM	M30 1 1/8"	SG11TM						
24"	M33 1 1/4"	SG11TM	M36 1 3/8"	SG11TM								
28"	M33 1 1/4"	SG11TM	M39 1 1/2"	SG13TE								
32"	M36 1 3/8"	SG11TM	M45 1 3/4"	SG13TE								
36"	M36 1 3/8"	SG11TM	M45 1 3/4"	SG13TE								
40"	M39 1 1/2"	SG13TE	M52 2"	SG15TE								
48"	M45 1 3/4"	SG13TE										
56"	M45 1 3/4"	SG13TE										
64"	M52 2"	SG15TE										
72"	M52 2"	SG15TE										
80"	M56 2 1/4"	SG15TE										

DIN FLAT

Nominal pipe size	Class			
	PN6		PN10	
	collet	tool	collet	tool
1 1/4"			M16 5/8"	SG4TM
1 1/2"			M16 5/8"	SG4TM
2"			M16 5/8"	SG4TM
2 1/2"			M16 5/8"	SG4TM
3"	M16 5/8"	SG4TM	M16 5/8"	SG4TM
4"	M16 5/8"	SG4TM	M16 5/8"	SG4TM
5"	M16 5/8"	SG4TM	M16 5/8"	SG4TM
6"	M16 5/8"	SG4TM	M20 3/4"	SG4TM
8"	M16 5/8"	SG4TM	M20 3/4"	SG4TM
10"	M16 5/8"	SG4TM	M20 3/4"	SG4TM
12"	M20 3/4"	SG4TM	M20 3/4"	SG4TM
14"	M20 3/4"	SG4TM	M20 3/4"	SG4TM
16"	M20 3/4"	SG4TM	M24 7/8"	SG6TM
18"	M20 3/4"	SG4TM	M24 7/8"	SG6TM
20"	M20 3/4"	SG4TM	M24 7/8"	SG6TM

DIN LAPPED

Nominal pipe size	Class			
	PN6		PN10	
	collet	tool	collet	tool
1 1/4"			M16 5/8"	SG4TM
1 1/2"			M16 5/8"	SG4TM
2"			M16 5/8"	SG4TM
2 1/2"			M16 5/8"	SG4TM
3"	M16 5/8"	SG4TM	M16 5/8"	SG4TM
4"	M16 5/8"	SG4TM	M16 5/8"	SG4TM
5"	M16 5/8"	SG4TM	M16 5/8"	SG4TM
6"	M16 5/8"	SG4TM	M20 3/4"	SG4TM
8"	M16 5/8"	SG4TM	M20 3/4"	SG4TM
10"	M16 5/8"	SG4TM	M20 3/4"	SG4TM
12"	M20 3/4"	SG4TM	M20 3/4"	SG4TM
14"	M20 3/4"	SG4TM	M20 3/4"	SG4TM
16"	M20 3/4"	SG4TM	M24 7/8"	SG6TM
18"	M20 3/4"	SG4TM	M24 7/8"	SG6TM
20"	M20 3/4"	SG4TM	M24 7/8"	SG6TM
24"	M24 7/8"	SG6TM	M27 1"	SG6TM
28"	M24 7/8"	SG6TM	M27 1"	SG6TM
32"	M27 1"	SG6TM	M30 1 1/8"	SG11TM
36"	M27 1"	SG6TM		
40"	M27 1"	SG6TM		

ASME SERIES A WELD NECK

Nominal pipe size	Class													
	150		300		400		600		900		1500		2500	
	collet	tool	collet	tool	collet	tool	collet	tool	collet	tool	collet	tool	collet	tool
1/2"									M20 3/4"	SG4TM	M20 3/4"	SG4TM	M20 3/4"	SG4TM
3/4"			M16 5/8"	SG4TM	M16 5/8"	SG4TM	M16 5/8"	SG4TM	M20 3/4"	SG4TM	M20 3/4"	SG4TM	M20 3/4"	SG4TM
1"			M16 5/8"	SG4TM	M16 5/8"	SG4TM	M16 5/8"	SG4TM	M24 7/8"	SG6TM	M24 7/8"	SG6TM	M24 7/8"	SG6TM
1 1/4"			M16 5/8"	SG4TM	M16 5/8"	SG4TM	M16 5/8"	SG4TM	M24 7/8"	SG6TM	M24 7/8"	SG6TM	M27 1"	SG6TM
1 1/2"			M20 3/4"	SG4TM	M20 3/4"	SG4TM	M20 3/4"	SG4TM	M27 1"	SG6TM	M27 1"	SG6TM	M30 1 1/8"	SG11TM
2"	M16 5/8"	SG4TM	M16 5/8"	SG4TM	M16 5/8"	SG4TM	M16 5/8"	SG4TM	M24 7/8"	SG6TM	M24 7/8"	SG6TM	M27 1"	SG6TM
2 1/2"	M16 5/8"	SG4TM	M20 3/4"	SG4TM	M20 3/4"	SG4TM	M20 3/4"	SG4TM	M20 3/4"	SG4TM	M27 1"	SG6TM	M30 1 1/8"	SG11TM
3"	M16 5/8"	SG4TM	M20 3/4"	SG4TM	M20 3/4"	SG4TM	M20 3/4"	SG4TM	M24 7/8"	SG6TM	M30 1 1/8"	SG11TM	M33 1 1/4"	SG11TM
3 1/2"	M16 5/8"	SG4TM	M20 3/4"	SG4TM	M24 7/8"	SG6TM	M24 7/8"	SG6TM						
4"	M16 5/8"	SG4TM	M20 3/4"	SG4TM	M24 7/8"	SG6TM	M24 7/8"	SG6TM	M30 1 1/8"	SG11TM	M33 1 1/4"	SG11TM	M39 1 1/2"	SG13TE
5"	M20 3/4"	SG4TM	M20 3/4"	SG4TM	M24 7/8"	SG6TM	M27 1"	SG6TM	M33 1 1/4"	SG11TM	M39 1 1/2"	SG13TE	M45 1 3/4"	SG13TE
6"	M20 3/4"	SG4TM	M20 3/4"	SG4TM	M24 7/8"	SG6TM	M27 1"	SG6TM	M30 1 1/8"	SG11TM	M36 1 3/8"	SG11TM	M52 2"	SG15TE
8"	M20 3/4"	SG4TM	M24 7/8"	SG6TM	M27 1"	SG6TM	M30 1 1/8"	SG11TM	M36 1 3/8"	SG11TM	M42 1 5/8"	SG13TE	M52 2"	SG15TE
10"	M24 7/8"	SG6TM	M27 1"	SG6TM	M30 1 1/8"	SG11TM	M33 1 1/4"	SG11TM	M36 1 3/8"	SG11TM	M48 1 7/8"	SG15TE	M64 2 1/2"	SG18TE
12"	M24 7/8"	SG6TM	M30 1 1/8"	SG11TM	M33 1 1/4"	SG11TM	M33 1 1/4"	SG11TM	M36 1 3/8"	SG11TM	M52 2"	SG15TE	M70 2 3/4"	SG18TE
14"	M27 1"	SG6TM	M30 1 1/8"	SG11TM	M33 1 1/4"	SG11TM	M36 1 3/8"	SG11TM	M39 1 1/2"	SG13TE	M56 2 1/4"	SG15TE		
16"	M27 1"	SG6TM	M33 1 1/4"	SG11TM	M36 1 3/8"	SG11TM	M39 1 1/2"	SG13TE	M42 1 5/8"	SG13TE	M64 2 1/2"	SG18TE		
18"	M30 1 1/8"	SG11TM	M33 1 1/4"	SG11TM	M36 1 3/8"	SG11TM	M42 1 5/8"	SG13TE	M48 1 7/8"	SG15TE	M70 2 3/4"	SG18TE		
20"	M30 1 1/8"	SG11TM	M33 1 1/4"	SG11TM	M39 1 1/2"	SG13TE	M42 1 5/8"	SG13TE	M52 2"	SG15TE	M76 3"	SG25TE		
22"														
24"	M33 1 1/4"	SG11TM	M39 1 1/2"	SG13TE	M45 1 3/4"	SG13TE	M48 1 7/8"	SG15TE	M64 2 1/2"	SG18TE	M90 3 1/2"	SG25TE		
26"	M33 1 1/4"	SG11TM	M42 1 5/8"	SG13TE	M42 1 5/8"	SG13TE	M48 1 7/8"	SG15TE	M70 2 3/4"	SG18TE				
28"	M33 1 1/4"	SG11TM	M42 1 5/8"	SG13TE	M42 1 5/8"	SG13TE	M52 2"	SG15TE	M76 3"	SG25TE				
30"	M33 1 1/4"	SG11TM	M45 1 3/4"	SG13TE	M45 1 3/4"	SG13TE	M56 2 1/4"	SG15TE	M76 3"	SG25TE				
32"	M39 1 1/2"	SG13TE	M48 1 7/8"	SG15TE	M48 1 7/8"	SG15TE	M56 2 1/4"	SG15TE	M84	SG25TE				
34"	M39 1 1/2"	SG13TE	M48 1 7/8"	SG15TE	M48 1 7/8"	SG15TE	M56 2 1/4"	SG15TE	M90 3 1/2"	SG25TE				
36"	M39 1 1/2"	SG13TE	M52 2"	SG15TE	M52 2"	SG15TE	M56 2 1/4"	SG15TE	M90 3 1/2"	SG25TE				
38"	M39 1 1/2"	SG13TE	M39 1 1/2"	SG13TE	M39 1 1/2"	SG13TE	M56 2 1/4"	SG15TE	M90 3 1/2"	SG25TE				
40"	M39 1 1/2"	SG13TE	M42 1 5/8"	SG13TE	M42 1 5/8"	SG13TE	M56 2 1/4"	SG15TE	M90 3 1/2"	SG25TE				
42"	M39 1 1/2"	SG13TE	M42 1 5/8"	SG13TE	M42 1 5/8"	SG13TE	M56 2 1/4"	SG15TE	M90 3 1/2"	SG25TE				
44"	M39 1 1/2"	SG13TE	M45 1 3/4"	SG13TE	M45 1 3/4"	SG13TE	M56 2 1/4"	SG15TE	M95 3 3/4"	SG25TE				
46"	M39 1 1/2"	SG13TE	M48 1 7/8"	SG15TE	M48 1 7/8"	SG15TE	M56 2 1/4"	SG15TE	M100 4"	SG25TE				
48"	M39 1 1/2"	SG13TE	M48 1 7/8"	SG15TE	M48 1 7/8"	SG15TE	M70 2 3/4"	SG18TE	M100 4"	SG25TE				

ASME SERIES A LAPPED

Class		150		300		400		600		900		1500		2500	
Nominal pipe size	collet	tool	collet	tool	collet	tool	collet	tool	collet	tool	collet	tool	collet	tool	
1/2"										M20 3/4"	SG4TM	M20 3/4"	SG4TM	M20 3/4"	SG4TM
3/4"			M16 5/8"	SG4TM	M16 5/8"	SG4TM	M16 5/8"	SG4TM	M20 3/4"	SG4TM	M20 3/4"	SG4TM	M20 3/4"	SG4TM	
1"			M16 5/8"	SG4TM	M16 5/8"	SG4TM	M16 5/8"	SG4TM	M24 7/8"	SG6TM	M24 7/8"	SG6TM	M24 7/8"	SG6TM	
1 1/4"			M16 5/8"	SG4TM	M16 5/8"	SG4TM	M16 5/8"	SG4TM	M24 7/8"	SG6TM	M24 7/8"	SG6TM	M27 1"	SG6TM	
1 1/2"			M20 3/4"	SG4TM	M20 3/4"	SG4TM	M20 3/4"	SG4TM	M27 1"	SG6TM	M27 1"	SG6TM	M30 1 1/8"	SG11TM	
2"	M16 5/8"	SG4TM	M16 5/8"	SG4TM	M16 5/8"	SG4TM	M16 5/8"	SG4TM	M24 7/8"	SG6TM	M24 7/8"	SG6TM	M27 1"	SG6TM	
2 1/2"	M16 5/8"	SG4TM	M20 3/4"	SG4TM	M20 3/4"	SG4TM	M20 3/4"	SG4TM	M27 1"	SG6TM	M27 1"	SG6TM	M30 1 1/8"	SG11TM	
3"	M16 5/8"	SG4TM	M20 3/4"	SG4TM	M20 3/4"	SG4TM	M20 3/4"	SG4TM	M24 7/8"	SG6TM	M30 1 1/8"	SG11TM	M33 1 1/4"	SG11TM	
3 1/2"	M16 5/8"	SG4TM	M20 3/4"	SG4TM	M24 7/8"	SG6TM	M24 7/8"	SG6TM	no flange		no flange		no flange		
4"	M16 5/8"	SG4TM	M20 3/4"	SG4TM	M24 7/8"	SG6TM	M24 7/8"	SG6TM	M30 1 1/8"	SG11TM	M33 1 1/4"	SG11TM	M39 1 1/2"	SG13TE	
5"	M20 3/4"	SG4TM	M20 3/4"	SG4TM	M24 7/8"	SG6TM	M27 1"	SG6TM	M33 1 1/4"	SG11TM	M39 1 1/2"	SG13TE	M45 1 3/4"	SG13TE	
6"	M20 3/4"	SG4TM	M20 3/4"	SG4TM	M24 7/8"	SG6TM	M27 1"	SG6TM	M30 1 1/8"	SG11TM	M36 1 3/8"	SG11TM	M52 2"	SG15TE	
8"	M20 3/4"	SG4TM	M24 7/8"	SG6TM	M27 1"	SG6TM	M30 1 1/8"	SG11TM	M36 1 3/8"	SG11TM	M42 1 5/8"	SG13TE	M52 2"	SG15TE	
10"	M24 7/8"	SG6TM	M27 1"	SG6TM	M30 1 1/8"	SG11TM	M33 1 1/4"	SG11TM	M36 1 3/8"	SG11TM	M48 1 7/8"	SG15TE	M64 2 1/2"	SG18TE	
12"	M24 7/8"	SG6TM	M30 1 1/8"	SG11TM	M33 1 1/4"	SG11TM	M33 1 1/4"	SG11TM	M36 1 3/8"	SG11TM	M52 2"	SG15TE	M70 2 3/4"	SG18TE	

ASME SERIES A SOCKET WELDED

Class		150		300		600		1500	
Nominal pipe size	collet	tool	collet	tool	collet	tool	collet	tool	
1/2"							M20 3/4"	SG4TM	
3/4"			M16 5/8"	SG4TM	M16 5/8"	SG4TM	M20 3/4"	SG4TM	
1"			M16 5/8"	SG4TM	M16 5/8"	SG4TM	M24 7/8"	SG6TM	
1 1/4"			M16 5/8"	SG4TM	M16 5/8"	SG4TM	M24 7/8"	SG6TM	
1 1/2"			M20 3/4"	SG4TM	M20 3/4"	SG4TM	M27 1"	SG6TM	
2"	M16 5/8"	SG4TM	M16 5/8"	SG4TM	M16 5/8"	SG4TM	M24 7/8"	SG6TM	
2 1/2"	M16 5/8"	SG4TM	M20 3/4"	SG4TM	M20 3/4"	SG4TM	M27 1"	SG6TM	
3"	M16 5/8"	SG4TM	M20 3/4"	SG4TM	M20 3/4"	SG4TM			

ASME SERIES B WELD NECK AND BLIND

Class		150		300		400		600		900	
Nominal pipe size	collet	tool	collet	tool	collet	tool	collet	tool	collet	tool	
26"	M20 3/4"	SG4TM	M33 1 1/4"	SG11TM	M36 1 3/8"	SG11TM	M42 1 5/8"	SG13TE	M64 2 1/2"	SG18TE	
28"	M20 3/4"	SG4TM	M33 1 1/4"	SG11TM	M39 1 1/2"	SG13TE	M45 1 3/4"	SG13TE	M70 2 3/4"	SG18TE	
30"	M20 3/4"	SG4TM	M36 1 3/8"	SG11TM	M39 1 1/2"	SG13TE	M48 1 7/8"	SG15TE	M76 3"	SG25TE	
32"	M20 3/4"	SG4TM	M39 1 1/2"	SG13TE	M42 1 5/8"	SG13TE	M52 2"	SG15TE	M76 3"	SG25TE	
34"	M24 7/8"	SG6TM	M39 1 1/2"	SG13TE	M42 1 5/8"	SG13TE	M56 2 1/4"	SG15TE	M80 3 1/4"	SG25TE	
36"	M24 7/8"	SG6TM	M42 1 5/8"	SG13TE	M45 1 3/4"	SG13TE	M56 2 1/4"	SG15TE	M76 3"	SG25TE	
42"	M27 1"	SG6TM	M45 1 3/4"	SG13TE							
48"	M30 1 1/8"	SG11TM	M48 1 7/8"	SG15TE							
54"	M30 1 1/8"	SG11TM	M48 1 7/8"	SG15TE							
60"	M33 1 1/4"	SG11TM	M56 2 1/4"	SG15TE							

API 6B WELD NECK

Nominal pipe size	Class					
	138 bar (2000 psi)		207 bar (3000 psi)		345 bar (5000 psi)	
	collet	tool	collet	tool	collet	tool
2 1/16"	M16 5/8"	SG4TM	M24 7/8"	SG6TM	M24 7/8"	SG6TM
2 9/16"	M20 3/4"	SG4TM	M27 1"	SG6TM	M27 1"	SG6TM
3 1/8"	M20 3/4"	SG4TM	M24 7/8"	SG6TM	M30 1 1/8"	SG11TM
4 1/16"	M24 7/8"	SG6TM	M30 1 1/8"	SG11TM	M33 1 1/4"	SG11TM
5 1/8"	M27 1"	SG6TM	M33 1 1/4"	SG11TM	M39 1 1/2"	SG13TE
7 1/16"	M27 1"	SG6TM	M30 1 1/8"	SG11TM	M36 1 3/8"	SG11TM
9"	M30 1 1/8"	SG11TM	M36 1 3/8"	SG11TM	M42 1 5/8"	SG13TE
11"	M33 1 1/4"	SG11TM	M36 1 3/8"	SG11TM	M48 1 7/8"	SG15TE

API 6B BLIND AND THREADED

Nominal pipe size	Class					
	138 bar (2000 psi)		207 bar (3000 psi)		345 bar (5000 psi)	
	collet	tool	collet	tool	collet	tool
2 1/16"	M16 5/8"	SG4TM	M24 7/8"	SG6TM	M24 7/8"	SG6TM
2 9/16"	M20 3/4"	SG4TM	M27 1"	SG6TM	M27 1"	SG6TM
3 1/8"	M20 3/4"	SG4TM	M24 7/8"	SG6TM	M30 1 1/8"	SG11TM
4 1/16"	M24 7/8"	SG6TM	M30 1 1/8"	SG11TM	M33 1 1/4"	SG11TM
5 1/8"	M27 1"	SG6TM	M33 1 1/4"	SG11TM	M39 1 1/2"	SG13TE
7 1/16"	M27 1"	SG6TM	M30 1 1/8"	SG11TM	M36 1 3/8"	SG11TM
9"	M30 1 1/8"	SG11TM	M36 1 3/8"	SG11TM	M42 1 5/8"	SG13TE
11"	M33 1 1/4"	SG11TM	M36 1 3/8"	SG11TM	M48 1 7/8"	SG15TE
13 5/8"	M33 1 1/4"	SG11TM	M36 1 3/8"	SG11TM		
16 3/4"	M39 1 1/2"	SG13TE	M42 1 5/8"	SG13TE		
21 1/4"	M42 1 5/8"	SG13TE	M52 2"	SG15TE		

API 6BX WELD NECK

Nominal pipe size	Class					
	690 bar (10000 psi)		1035 bar (15000 psi)		1380 bar (20000 psi)	
	collet	tool	collet	tool	collet	tool
1 13/16"	M20 3/4"	SG4TM	M24 7/8"	SG6TM	M27 1"	SG6TM
2 1/16"	M20 3/4"	SG4TM	M24 7/8"	SG6TM	M30 1 1/8"	SG11TM
2 9/16"	M24 7/8"	SG6TM	M27 1"	SG6TM	M33 1 1/4"	SG11TM
3 1/16"	M27 1"	SG6TM	M30 1 1/8"	SG11TM	M36 1 3/8"	SG11TM
4 1/16"	M30 1 1/8"	SG11TM	M36 1 3/8"	SG11TM	M45 1 3/4"	SG13TE
5 1/8"	M30 1 1/8"	SG11TM				
7 1/16"	M39 1 1/2"	SG13TE	M39 1 1/2"	SG13TE	M52 2"	SG15TE
9"	M39 1 1/2"	SG13TE				
11"	M45 1 3/4"	SG13TE				
13 5/8"	M48 1 7/8"	SG15TE				
16 3/4"	M48 1 7/8"	SG15TE				

API 6BX BLIND AND TEST

Nominal pipe size	Class					
	690 bar (10000 psi)		1035 bar (15000 psi)		1380 bar (20000 psi)	
	collet	tool	collet	tool	collet	tool
1 13/16"	M20 3/4"	SG4TM	M24 7/8"	SG6TM	M27 1"	SG6TM
2 1/16"	M20 3/4"	SG4TM	M24 7/8"	SG6TM	M30 1 1/8"	SG11TM
2 9/16"	M24 7/8"	SG6TM	M27 1"	SG6TM	M33 1 1/4"	SG11TM
3 1/16"	M27 1"	SG6TM	M30 1 1/8"	SG11TM	M36 1 3/8"	SG11TM
4 1/16"	M30 1 1/8"	SG11TM	M42 1 5/8"	SG13TE	M45 1 3/4"	SG13TE

9.

REGULATORY INFORMATION

9.1

REGISTERED HEAD OFFICE

EQUALIZER INTERNATIONAL LTD.
Equalizer House
Claymore Drive
Aberdeen
Scotland
AB23 8GD

10.

PARTS LISTS & SERVICE KITS

SG13TE PARTS LIST

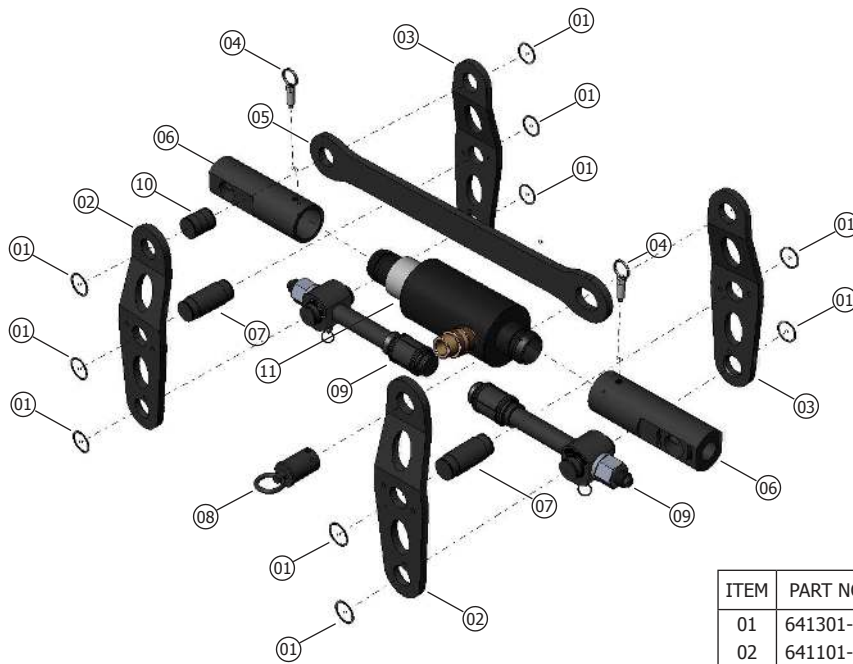

ITEM	PART NO.	DESCRIPTION	QUANTITY
01	641301-01	LEG RETAINING RING	10
02	641101-01	LEG W/O PIN	02
03	641101-02	LEG WITH PIN	02
04	900502-01	M10 SPRING PLUNGER	02
05	641501-01	CANTILEVER	01
06	641901-01	ACTUATOR UNION	02
07	641401-01	ACTUATOR PIN	02
08	641701-01	PULL PIN	01
09		SEE COLLET HEAD PARTS LIST	02
10	643201-01	CANTILEVER PIN	01
11	644001-01	ACTUATOR ASSEMBLY	01

COLLET HEAD PARTS LIST

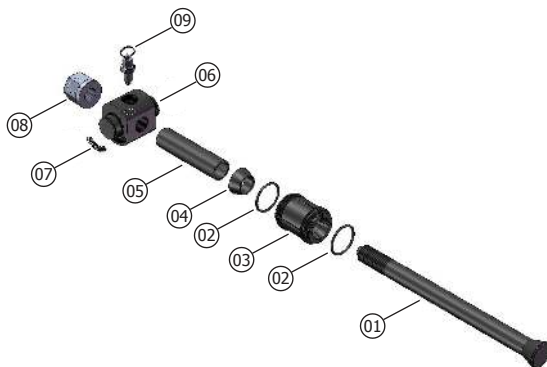

ITEM	PART NO.	DESCRIPTION	QUANTITY
01	640401-01	COLLET HOLDER	01
02	642201-01	M39 SPRING RING	02
	642401-01	M42 SPRING RING	02
	642601-01	M45 SPRING RING	02
03	640101-90	M39 COLLET	01
	640201-90	M42 COLLET	01
	640301-90	M45 COLLET	01
04	640501-01	DRIVE CONE	01
05	641601-01	DRIVE TUBE	01
06	640601-01	COLLET UNION	01
07	402201-01	CENTRING SPRING 1	01
08	640901-01	COLLET NUT	01
09	641001-01	M12 SPRING PLUNGER	01

SG15TE PARTS LIST

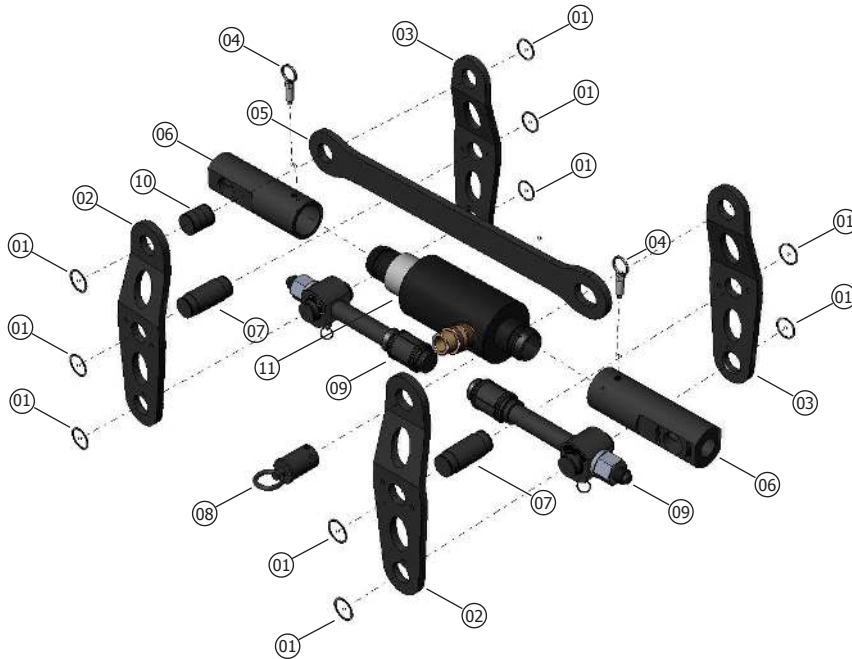

ITEM	PART NO.	DESCRIPTION	QUANTITY
01	641301-01	LEG RETAINING RING	10
02	651101-01	LEG W/O PIN	02
03	651101-02	LEG WITH PIN	02
04	900502-01	M10 SPRING PLUNGER	02
05	651501-01	CANTILEVER	01
06	651901-01	ACTUATOR UNION	02
07	651401-01	ACTUATOR PIN	02
08	641701-01	PULL PIN	01
09		SEE COLLET HEAD PARTS LIST	
10	643201-01	CANTILEVER PIN	01
11	644001-01	ACTUATOR ASSEMBLY	01

COLLET HEAD PARTS LIST

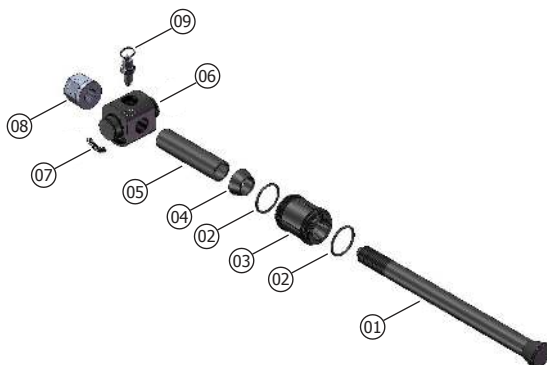

ITEM	PART NO.	DESCRIPTION	QUANTITY
01	650401-01	COLLET HOLDER	01
02	652201-01	M48 SPRING RING	02
	652401-01	M52 SPRING RING	02
	652601-01	M56 SPRING RING	02
03	650101-90	M48 COLLET	01
	650201-90	M52 COLLET	01
	650301-90	M56 COLLET	01
04	650501-90	DRIVE CONE	01
05	651601-90	DRIVE TUBE	01
06	650601-90	COLLET UNION	01
07	402201-90	CENTRING SPRING 1	01
08	650901-90	COLLET NUT	01
09	641001-90	COLLET SPRING PLUNGER	01



EQUALIZER INTERNATIONAL LTD.

Head Office
Equalizer House
Claymore Drive
Aberdeen
Scotland
UK

AB23 8GD

t: +44 (0) 1224 701970

f: +44 (0) 1224 823791

www.equalizerinternational.com