

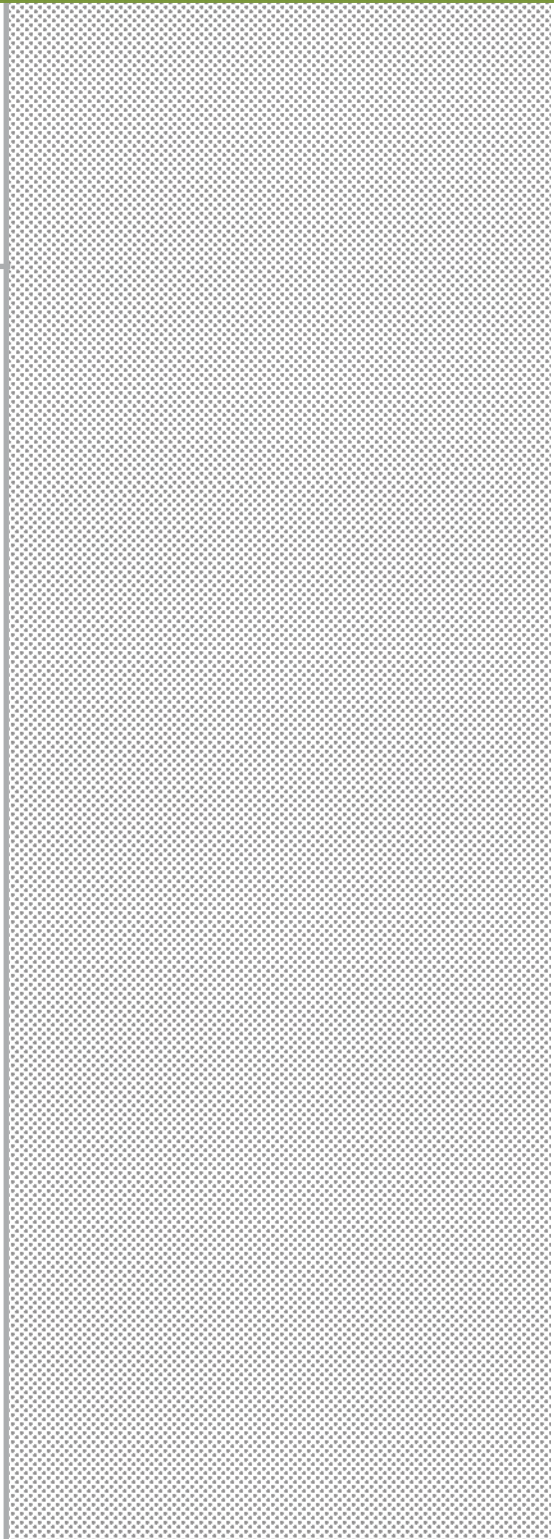

# SG18TE SG25TE

*Torque and tension specialist*

SECURE-GRI P  
IN-LINE  
HYDRAULIC  
FLANGE  
SPREADERS



# CONTENTS

- 1. INTRODUCTION
- 2. TOOL SAFETY
  - 2.1 GENERAL SAFETY
  - 2.2 PERSONNEL COMPETENCY
  - 2.3 DISCLAIMER
  - 2.4 DEFINITION OF TERMS
  - 2.5 HAZARDS
- 3. TOOL OPERATION
  - 3.1 GENERAL GUIDANCE
  - 3.2 COLLET SELECTION
  - 3.3 BOLT HOLE MEASUREMENT
  - 3.4 COLLET REPLACEMENT
  - 3.5 STANDARD TOOL INSTALLATION & OPERATION
  - 3.6 ACCESS GAP INSTALLATION AND OPERATION
  - 3.7 RESTRICTED ACCESS INSTALLATION AND OPERATION
- 4. TOOL MAINTENANCE
  - 4.1 INSPECTION
  - 4.2 DISASSEMBLY
  - 4.3 SERVICING
  - 4.4 STORAGE & TRANSPORTATION
  - 4.5 LONG-TERM STORAGE - MAINTENANCE PLAN
- 5. SG18TE
  - 5.1 TOOL CAPABILITIES
  - 5.2 KIT CONTENTS
  - 5.3 DIMENSIONS
- 6. SG25TE
  - 6.1 TOOL CAPABILITIES
  - 6.2 KIT CONTENTS
  - 6.2 DIMENSIONS
- 7. TROUBLESHOOTING
  - 7.1 SG18TE/SG25TE TROUBLESHOOTING
- 8. SECURE GRIP RANGE OF APPLICATION
- 9. REGULATORY INFORMATION
- 10. PARTS LISTS & SERVICE KITS

24/09/2018

# 1.

## INTRODUCTION

The Equalizer™ SG Secure Grip tools are aids for use in normal maintenance and installation procedures. The tools can be used during pipework construction, commissioning or during routine maintenance.

The In-Line Hydraulic Secure Grip Flange Spreading Tools are used to spread flanges with little or no access gap producing a spreading force up to:

- 36 T (360 kN) for the SG18TE when used in pairs
- 50 T (500 kN) for the SG25TE when used in pairs

It is essential that the user familiarises themselves with the contents of this manual prior to using the tool.

This manual contains information for the following tools:

- SG18TE Secure Grip In-Line Hydraulic Flange Spreader
- SG25TE Secure Grip In-Line Hydraulic Flange Spreader

# 2.

## TOOL SAFETY

### 2.1

#### GENERAL SAFETY

These instructions cover the safe operation and maintenance of THE EQUALIZER SG18TE and SG25TE SECURE GRIP IN-LINE HYDRAULIC FLANGE SPREADING tools. The use of these tools should be as part of a broader task-based risk assessment, which should be carried out by the operation supervisor or other competent person.

Failure to comply with the safety information contained within this manual could result in personal injury or equipment damage. Read all instructions, warnings and cautions carefully, and follow all safety precautions.

The safety of the operator, any assisting personnel and the general public is of paramount importance. Always work in accordance with applicable national, local, site & company-wide safety procedures.

### 2.2

#### PERSONNEL COMPETENCY

Only personnel deemed competent in the use of mechanical and hydraulic equipment should use these tools.

### 2.3

#### DISCLAIMER

Equalizer cannot be held responsible for injury or damage resulting from unsafe product use, lack of maintenance or incorrect product and/or system operation. If in doubt as to the safety precautions and applications, contact Equalizer using the contact details at the back of this manual.

## 2.4

### DEFINITION OF TERMS

A CAUTION is used to indicate correct operating or maintenance procedures and practices to prevent damage to, or destruction of equipment or other property.

A WARNING indicates a potential danger that requires correct procedures or practices to avoid personal injury.

A DANGER is only used when your action or lack of action may cause serious injury or even death.



DO: an illustration showing how the tool should be used.



DON'T: an illustration showing an incorrect way to use a tool.

## 2.5

### HAZARDS



WARNING: ensure all hydraulic components are rated to a safe working pressure of 700 bar (10 000psi).



WARNING: Do not overload equipment. The risk of hydraulic overloading can be minimised by using the Equalizer Hand Pump, which has a factory-set safety valve preventing the safe working pressure being exceeded.

If alternative hydraulic pumps are used, ensure that there are adequate systems to limit the working pressure to 700 bar (10 000 psi).



CAUTION: ensure components are protected from external sources of damage, such as excessive heat, flame, moving machine parts, sharp edges and corrosive chemicals.



CAUTION: Take care to avoid sharp bends and kinks in hydraulic hoses. Bends and kinks can cause severe back-up pressure and cause hose failure. Protect hoses from dropped objects; a sharp impact may cause internal damage to hose wire strands. Protect hoses from crush risks, such as heavy objects or vehicles; crush damage can cause hose failure.



WARNING: Applying pressure to a damaged hose may cause it to rupture.



WARNING: Immediately replace worn or damaged parts. Use only genuine Equalizer parts from approved distributors or service centres. Equalizer parts have been engineered and manufactured to be fit-for-purpose.



DANGER: To minimise risk of personal injury keep hands and feet away from the tool and workpiece during operation.



WARNING: Always wear suitable clothing and Personal Protective Equipment (PPE). Do not handle pressurised hoses; escaping oil under pressure can penetrate the skin, causing serious injury. Seek medical attention immediately if oil penetration is suspected.



WARNING: Only pressurize complete and fully connected hydraulic systems. Do not pressurize systems that contain unconnected couplers.



CAUTION: Do not lift hydraulic equipment by the hoses or couplers. Use only the designated carrying handles.



CAUTION: Lubricate tools as directed in this manual prior to operation. Use only approved lubricants of high quality, following the lubricant manufacturers instructions.



CAUTION: Only use the designated anchor point for fixing the lanyard. Do not attach the lanyard to the plastic handle.



DANGER: Care should be taken when using the lanyard to avoid entanglement with body parts.



The vibration total value to which this tool is subjected does not exceed 2.5 m/s<sup>2</sup>.



WARNING: Never place fingers in a joint held by an activated tool



CAUTION: Never hammer or force the tool into a bolt hole; if it does not fit easily you are using the wrong size of tool.

# 3.

## TOOL OPERATION

### 3.1

#### GENERAL GUIDANCE

The Secure-Grip In-Line Hydraulic Tools spread flange joints by engaging collets into the bolt-holes. They can easily spread flange joints with zero access gap, which traditional wedge-type flange spreaders cannot spread.

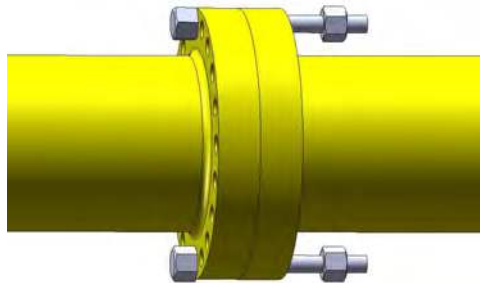

The collets are suited to the sizes of the bolt-holes and should be selected prior to commencing work by following the instructions in this section.

Replacement collets or different collets to suit different bolt-hole sizes are available from a local Equalizer distributor.

### 3.2

#### COLLET SELECTION



**WARNING:** It is important that the correct size of collet is used. An undersized collet could allow the collet holder to pull through its bore. An oversized collet has the potential to become jammed in the bolt-hole.

To select the applicable tool and collet for your flange please refer to the Secure-Grip application charts at the back of this manual (section 8).

The SG range of Secure-Grip tools have a range of collets which are applicable to the following bolts and flange bolt-hole diameters shown in the table below.

If the specification of the flange is unknown then the vernier calliper supplied in the kit should be used to determine the correct collet.

Minimum bolt-hole diameter (mm)	Maximum bolt-hole diameter (mm)	COLLET	TOOL
59.5mm (2.34")	63mm (2.48")	<b>M60 (2 3/8")</b>	SG18TE
63mm (2.48")	69mm (2.72")	<b>M64 (2 1/2")</b>	
69mm (2.72")	75mm (2.95")	<b>M70 (2 3/4")</b>	
75mm (2.95")	83mm (3.27")	<b>M76 (3")</b>	SG25TE
79mm (3.11")	86mm (3.39")	<b>M80 (3 1/4")</b>	
83mm (3.27")	89mm (3.5")	M84	
89mm (3.5")	95mm (3.74")	<b>M90 (3 1/2")</b>	
94mm (3.7")	101mm (3.98")	<b>M95 (3 3/4")</b>	
99mm (3.90")	108mm(4.25")	<b>M100 (4")</b>	

### 3.3 BOLT HOLE MEASUREMENT

To ensure a true measurement is taken, hold the vernier calliper:

- square to the flange face
- in the middle of the bolt-hole

It is important that the vernier calliper is held in the middle of the bolt-hole, and not held at an angle to the flange face, nor used on a bolt-hole which is worn, damaged or distorted, as these actions may result in the selection of an incorrect size of collet.

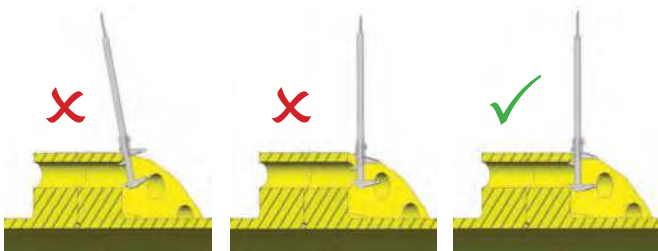

To confirm that the bolt-hole is round, take two separate measurements with the vernier calliper turned through 90° between measurements.

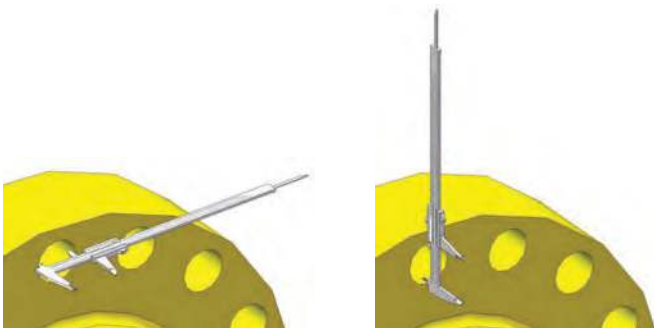

To read the measurement from the vernier calliper, scan along the desired scale from left to right. In this example, the major figure is 60 mm, this is added to the minor figure of 8 mm (indicated by where the vernier scale aligns with the main scale), giving a total measurement of 68 mm.

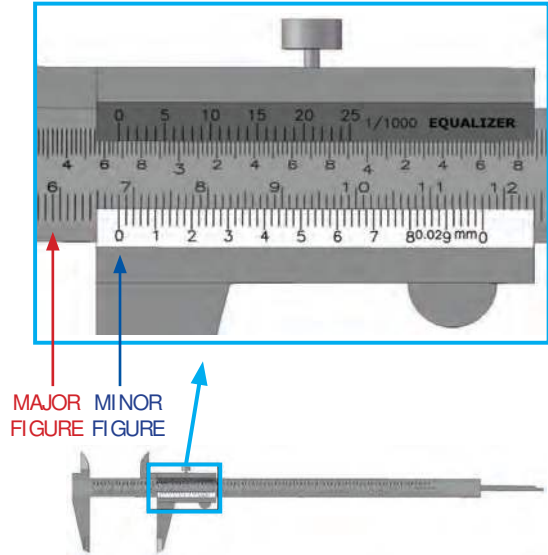

With a bolt-hole size of 68 mm, the operator can determine which collet and tool is appropriate to this flange by referring to the table. For example: 68 mm falls within the 63 mm minimum and 69 mm maximum bolt-hole sizes.

Therefore, collet identification is M64 / 2 1/2"

If the measurement contains fractions of a millimetre the method of reading the vernier calliper is slightly different. In this example, the major figure is 40 mm (read in the same way as previously described). The minor figure is 7 mm (read to the left of the zero). The fraction is 0.5 mm (read from where the vernier scale lines up with the main scale). This gives a total measurement of 47.5 mm.

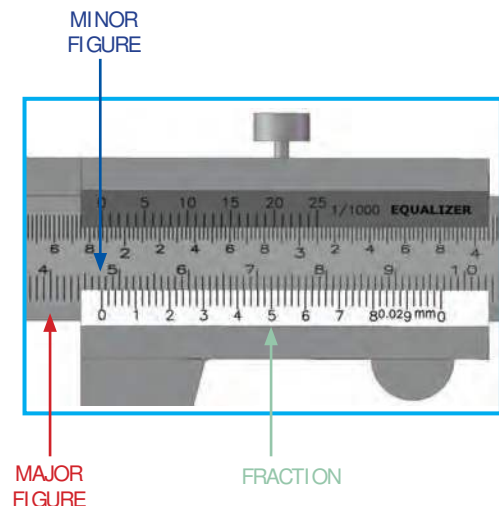

Each tool in the Secure-Grip range comes with the appropriate sizes of Collets for that tool. If the Collet labelling is worn or missing, then the Collet can be measured to ensure that the correct size is selected.

An accurate measurement can only be obtained with the Collet mounted on the Collet Holder. To do this:

- Remove the Collet Head Assembly from the tool and disassemble (see Section 3.4 for details)
- Slide the Collet over the Collet Holder
- Measure the centre section of the Collet with the vernier calliper
- Identify the Collet using the chart below and select the correct size for the flange

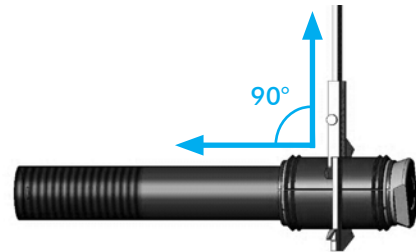

**WARNING:** The Secure-Grip collets are consumable items. The lifespan of a collet will vary depending on the flange materials with which it is used. To increase the lifespan of the collets it is recommended that they are flipped through 180° on the collet holder, this will produce more even wear across the four ridges on the outer profile of the collet. See Section 3.4 for details on collet removal and replacement.

Centre Section Ø	COLLET	Minimum bolt-hole diameter (mm)	Maximum bolt-hole diameter (mm)
56mm	<b>M60 2 3/8"</b>	59.5mm (2.34")	63mm (2.48")
59mm	<b>M64 2 1/2"</b>	63mm (2.48")	69mm (2.72")
66mm	<b>M70 2 3/4"</b>	69mm (2.72")	75mm (2.95")
71mm	<b>M76 3"</b>	75mm (2.95")	83mm (3.27")
75mm	M80 3 1/4"	79mm (3.11")	86mm (3.39")
80mm	M84	83mm (3.27)	89mm (3.5")
84mm	<b>M90 3 1/2"</b>	89mm (3.5")	95mm (3.74")
90mm	<b>M95 3 3/4"</b>	94mm (3.7")	101mm (3.98")
95mm	<b>M100 4"</b>	99mm (3.90")	108mm(4.25")

### 3.4 COLLET REPLACEMENT

Once the correct collet has been selected it may be necessary to change the collet on the tool and the collet on the spreading plug:

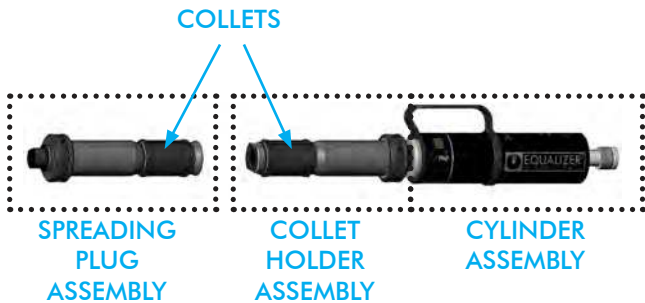

Unscrew the collet holder assembly from the cylinder assembly



TOOL COLLET:

Slide the collet holder assembly off the piston rod

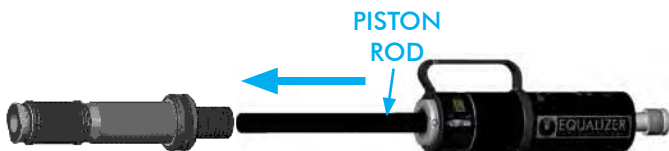

Unscrew the drive nut



Slide the drive cone off



Slide the collet off



Select the correct size of collet for the flange being worked on and reassemble by reversing the procedure



**CAUTION:** It is essential that the collet holder is screwed fully into the cylinder assembly with the indicator dowel next to the green tick. The safety of the tool will be compromised if it is not, and damage to the tool and injury to the operator may result.



Incorrect:

Do not use with the indicator dowel in this position. The collet holder must be screwed right in until the indicator dowel is beside the green tick.



Correct:

The indicator dowel is now beside the green tick. The tool is now ready to use.



The spring-loaded indicator dowel shows how far the collet holder has been screwed into the cylinder assembly. If the collet holder is not screwed right in before use, failure of either the collet holder or the cylinder assembly may result, potentially injuring the operator and damaging the flange being spread.

SPREADING PLUG COLLET:

Unscrew the drive nut



Slide the drive cone off



Slide the collet off



Select the correct size of collet for the flange being worked on and reassemble by reversing the procedure



### 3.5 STANDARD TOOL INSTALLATION AND OPERATION

Once the correct Collet has been selected and mounted, tool operation can commence.



**WARNING:** Before attaching the tool ensure at least two flange bolts remain in place 180 degrees apart with nuts loosened sufficiently enough for flange work to be carried out. These bolts will reduce lateral flange movement during flange spreading.

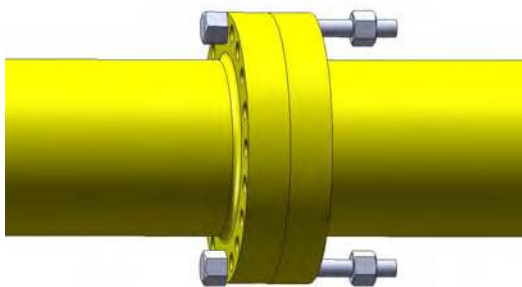

Measure the thickness of the flange using the vernier calliper provided. Lock the calliper in position by tightening the locking screw.

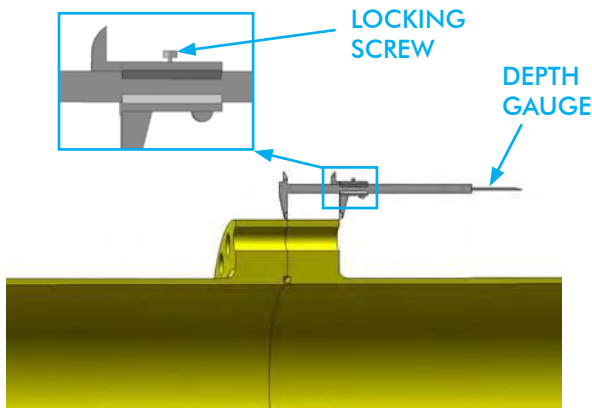

Select one of the the bolt-holes adjacent to the remaining bolts.

Insert the depth gauge part of the vernier calliper into the bolt-hole keeping the base of the calliper flush with the bolting face of the flange

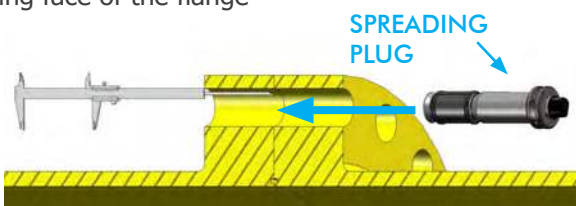

Insert the spreading plug into the opposite end of the same bolt-hole until it touches the end of the depth gauge (so that the collet is fully through one flange but not entering the other)

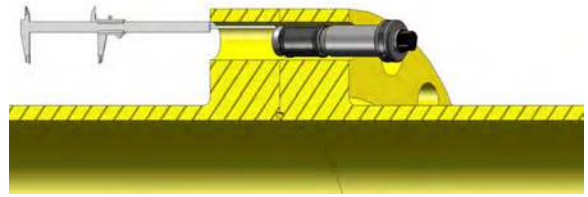

Tighten the drive nut with the 'C' spanner. The collet will now have a secure grip in the bolt-hole.

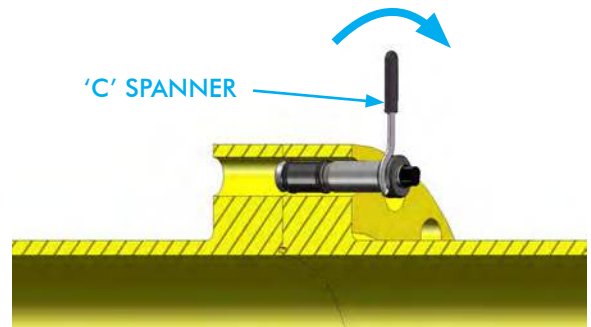

Fit the complete tool into the other side of the bolt-hole until it touches the spreading plug

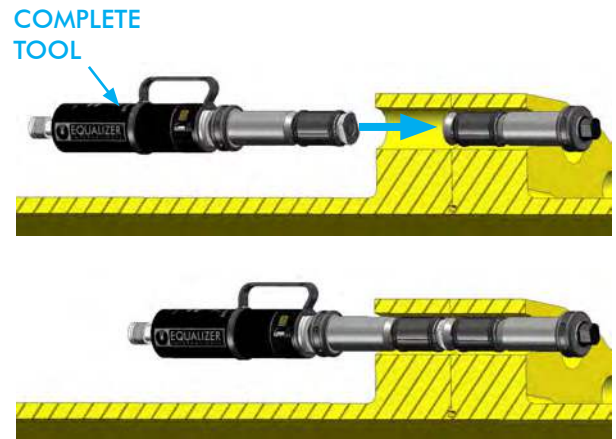

Tighten the drive nut to lock the collet in the bolt-hole

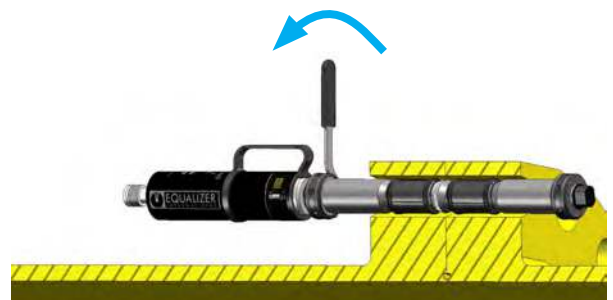

Fit the second tool 180° opposite to the first tool using the same method

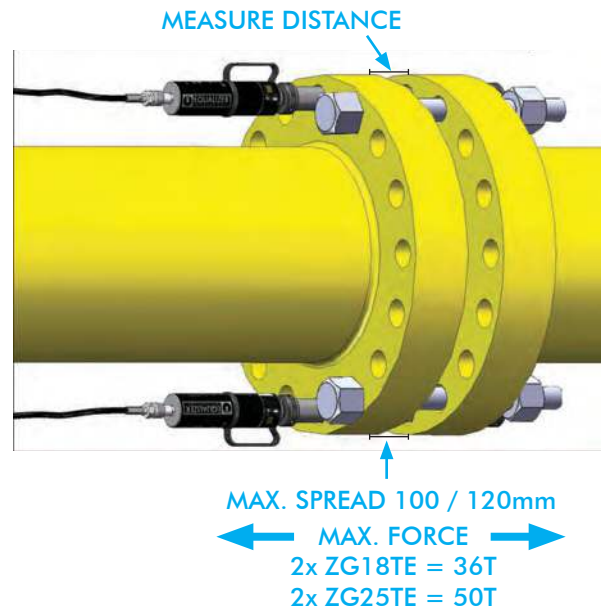
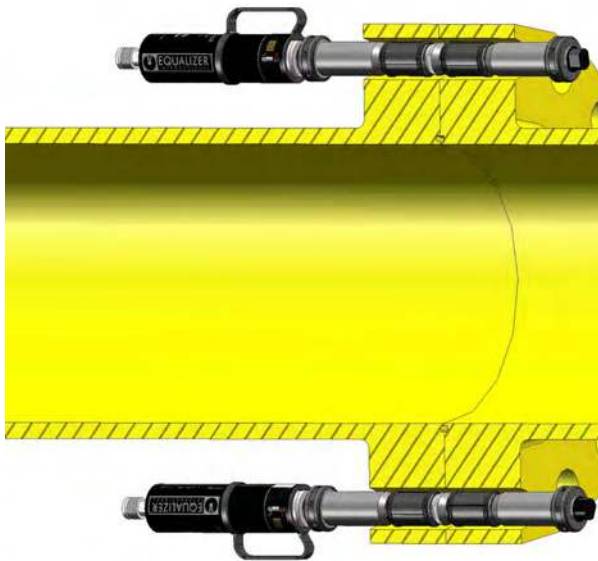

Connect the hand pumps using the hydraulic hoses supplied, ensuring that all couplers are fully hand tightened and both release valves are closed hand tight.

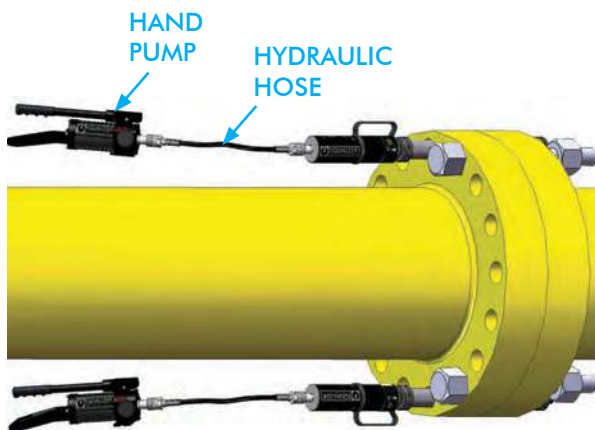

Once the flange has been spread and prior to any maintenance works the safety blocks must be inserted between the flanges. These are held in position by replacing two of the flange bolts.

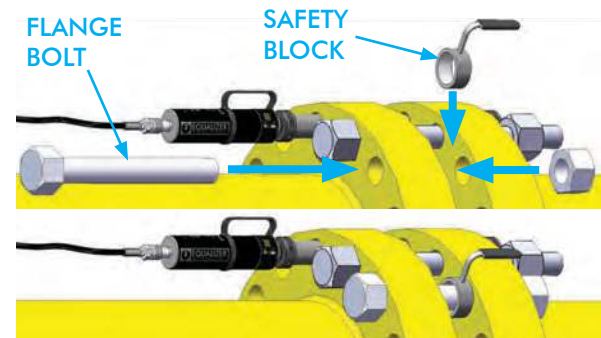

Flange spreading can now begin.

Prime the hand pumps, increasing the pressure on each tool gradually (using the gauge on each hand pump as a guide).

The spreading force available from the SG18TE is 18 T (36 T when used in pairs), and the maximum spreading distance is 100 mm (3.94")

The spreading force available from the SG25TE is 25 T (50 T when used in pairs), and the maximum spreading distance is 120 mm (4.72") provided the tools start with the flanges in the fully closed position.

Following any maintenance works and prior to closing the flange joint, the safety block must be removed. The release valves on the hand pumps should now be turned anticlockwise gently and evenly, adjusting as necessary to keep the flanges parallel until the flange is fully closed and there is no load on the tools. The tools can then be removed by reversing the installation procedure

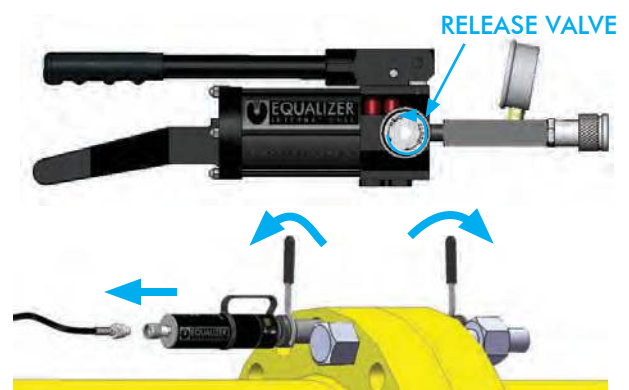

### 3.6 ACCESS GAP INSTALLATION AND OPERATION

The Secure-Grip tools are also ideal for use on flanges with an access gap. Using the spreading plugs is unnecessary as spacers can be used instead. The spacer assemblies can be adjusted from 12.5 mm to 50 mm thick (SG18TE only) using the 50 mm adapter and fixing screw. Use the largest size that will easily fit in the access gap.

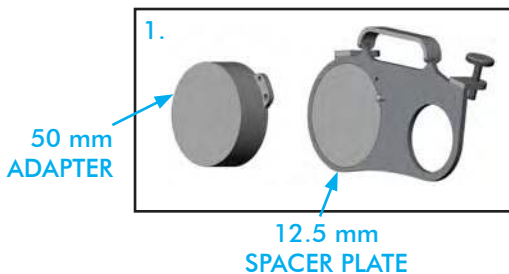
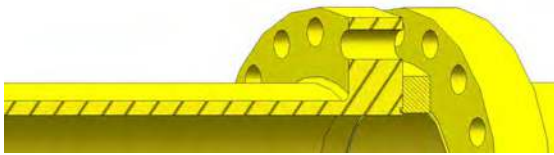

Insert the spacer into the access gap and hold it in position using one of the flange bolts

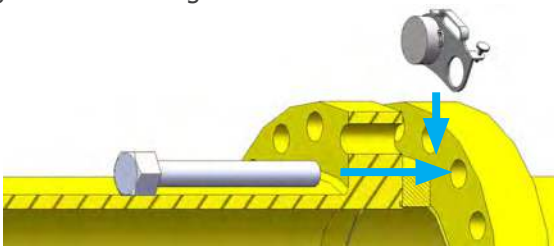

Turn the thumbscrew clockwise to lock the spacer against the flange

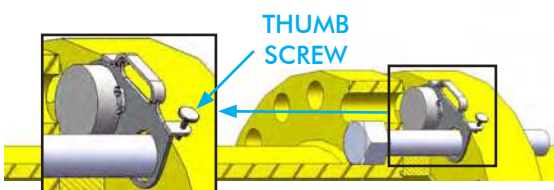

Insert the complete tool into the bolt-holes as shown

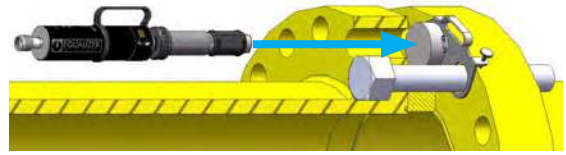

Tighten the drive nuts with the 'C' spanner

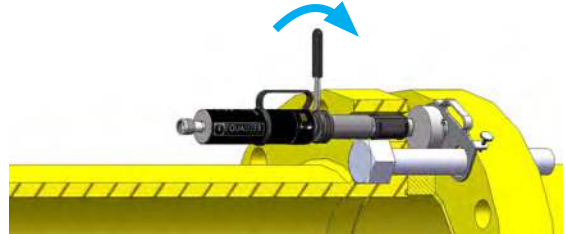

The procedure can now be completed by following the remaining steps of the standard installation procedure

### 3.7 RESTRICTED ACCESS INSTALLATION AND OPERATION

The Secure-Grip in-line hydraulic tools are also ideal for use where access to the flange is restricted. As in the standard operation, two tools should be used in order to avoid flange distortion, with the tools positioned 180° from each other on the flange.

Measure the thickness of the flange with the vernier calliper provided

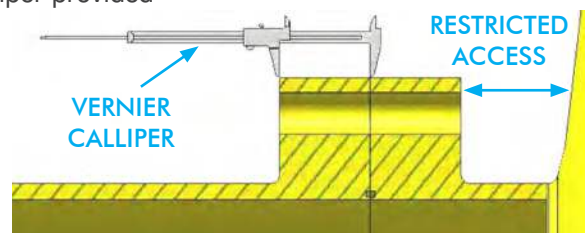

Remove the drive nut from the spreading plug and position it between the flange and the restriction as shown. With the nut removed ensure the drive cone does not fall or slide off the spreading plug during installation.

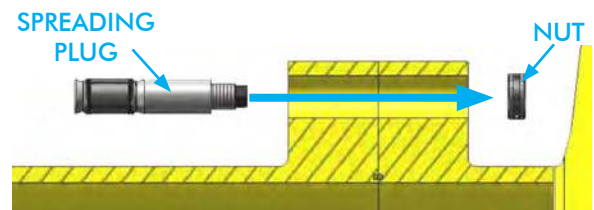

Pass the spreading plug collet and drive cone through the bolt-hole and refit the drive nut.

Using the vernier calliper as a depth gauge, adjust the position of the spreading plug in the bolt-hole so that the collet is fully through one flange but not entering the bolt-hole of the other.

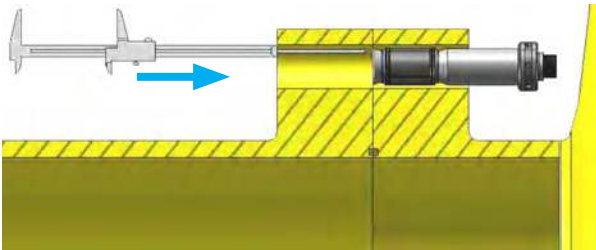

Tighten the drive nut with the 'C' spanner

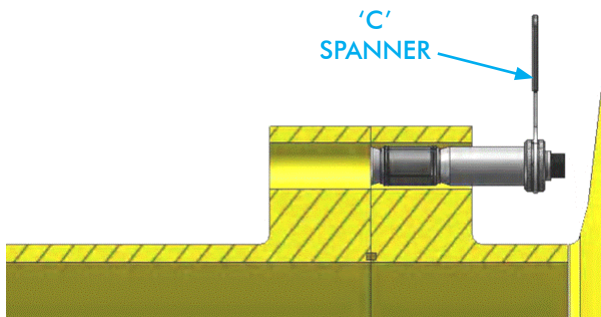

The procedure can now be completed by following the remaining steps of the standard installation procedure

# 4.

## TOOL MAINTENANCE

### 4.1 INSPECTION

On return from each job and before allocation against subsequent work the completeness of the Equalizer Secure-Grip hydraulic tool kits must be established and items examined to ensure that they are serviceable. The Secure-Grip tools should be stored in a cool dry place.

At regular intervals and specifically after exposure to salt water Secure-Grip in-line hydraulic tools should be dismantled, all moving parts cleaned with a clean rag and WD40 (or similar) to remove dirt and old grease, and then relubricated

### 4.2 DISASSEMBLY

Unscrew the collet holder assembly from the cylinder assembly



Slide the collet holder assembly off the piston rod



Unscrew the drive nut



Slide the drive cone and collet off



Unscrew the drive nut from the spreading plug



Slide the drive cone and collet off



Remove the nylon washers from both drive nuts

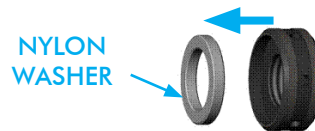

Unscrew the piston rod from the cylinder assembly



Unscrew the indicator dowels to release the spring collar and safety spring

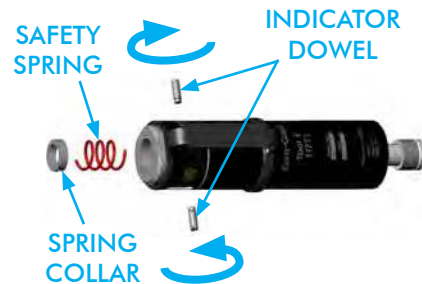

## 4.3

### SERVICING

Clean all components with a rag and WD40 (or similar), removing any visible dirt or grit (paying particular attention to the collets, collet holder and collet plug).

Smear all mating surfaces with a high performance molybdenum disulphide grease such as Rocol Sapphire Hi-Load 2. Inspect all components for wear and damage. Replace all worn and damaged components with genuine Equalizer spares.

Reassemble by reversing the disassembly procedure.



**CAUTION:** It is essential that the piston rod is screwed fully into the cylinder assembly. Failure to do this will result in damage to the threaded section and possible tool failure.

6. Once bags have been closed and sealed DO NOT re-open. Any visual inspections must be done with closed and sealed bags. If bags are opened the components will have to be dried, re-coated and re-sealed in bags/shrink wrap.
7. Replace silica gel (100g) EVERY TIME the case is opened.  
NOTE: depending on moisture content of air, silica gel should be changed weekly.
8. Visually inspect kits after 30-days and every 30-days thereafter. Remember to replace silica gel before closing case.

## 4.4

### STORAGE & TRANSPORTATION

Equalizer tools should be stored in a cool dry place. Tools should always be cleaned, serviced and lubricated prior to storage. Ensure that tools are stored in their designated packing cases.

## 4.5

### LONG-TERM STORAGE - MAINTENANCE PLAN

1. Rub components down with a dry cloth to remove moisture.
2. Coat EVERY surface and contact point with a corrosion inhibitor. Where necessary, coat inside and outside of component
3. Nuts and threads must also be coated with a corrosion inhibitor.
4. Once surfaces have been coated, seal individual components in clear plastic bags or clear vacuum bags or clear shrink wrap.  
NOTE: bags/shrink wrap must be clear for visibility. Take care when using shrink wrap that the tool is/ components are still easy to see.
5. Remove all or, where not vacuum sealed, as much air from bags as possible.

# 5.

## SG18TE

### 5.1

#### SG18TE TOOL CAPABILITIES

SPREADING FORCE = 18 T (180 kN) per tool

It is recommended that tools are used in pairs giving  
2 x 18 T = 36 T (360 kN)

If using the Equalizer HP350S Hand Pump (or if a hydraulic pressure gauge is fitted), the spreading force per tool can be determined by taking a reading from the gauge. Gauge pressures will produce spreading forces as set out below.

Pressure		Spreading force	
Bar	psi	T	kN
69	1000	1.8	18
207	3000	5.4	54
345	5000	9	90
483	7000	12.6	126
690	10,000	18	180

SPREADING DISTANCE: **0 - 100mm (0 - 3.94")**

Hydraulic oil grade: 15 centistokes(cSt) @ 40°C tested by ASTM D 445

### 5.2

#### SG18TE KIT CONTENTS

Product Code: SG18TESTD

- 1 x SG18TE Tool
- 1 x Spreading Plug
- 1 x 10,000 psi (700 bar) HP350S Sealed Hand Pump with Gauge
- 1 x 10,000 psi (700 bar) Hydraulic Hose, 2m (78.75")
- 1 x 300 mm (12") Vernier Calliper
- 1 x 12.5 mm (0.49") Spacer
- 1 x 5 mm Allen Key
- 1 x 50 mm (1.97") Spacer
- 1 x Safety Block
- 2 x M60 Collets
- 2 x M64 (2 1/2") Collets
- 2 x M70 (2 3/4") Collets
- 1 x Instruction Manual
- 1 x Carry-Case with Protective Foam Inserts



Carry Case Dimensions:

890 mm x 570 mm x 165 mm (35.0" x 22.4" x 6.5")

Gross Kit Weight: 45kg (99lbs)

Tool only weight: 14kg (30.8lbs)

## 5.3

### SG18TE DIMENSIONS

#### CLOSED DIMENSIONS

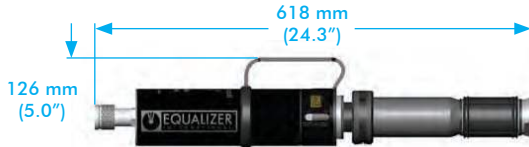

#### OPEN DIMENSIONS



#### SPREADING PLUG DIMENSIONS

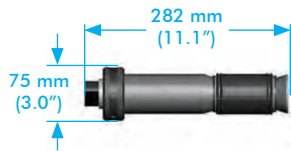



# 6.

## SG25TE

### 6.1

#### SG25TE TOOL CAPABILITIES

SPREADING FORCE = 25 T (250 kN) per tool

It is recommended that tools are used in pairs giving  
2 x 25 = 50 T (500 kN)

If using the Equalizer HP550S Hand Pump (or if a hydraulic pressure gauge is fitted), the spreading force per tool can be determined by taking a reading from the gauge. Gauge pressures will produce spreading forces as set out below.

Pressure		Spreading force	
Bar	psi	T	kN
69	1000	2.5	25
207	3000	7.5	75
345	5000	12.5	125
483	7000	17.5	175
690	10,000	25	250

SPREADING DISTANCE: **0 - 120mm (0 - 4.72")**

Hydraulic oil grade: 15 centistokes(cSt) @ 40°C tested by ASTM D 445

### 6.2

#### SG25TE KIT CONTENTS

Product Code: SG25TESTD

- 1 x SG25TE Tool
- 1 x Spreading Plug
- 1 x 10,000 psi (700 bar) HP550S Sealed Hand Pump with Gauge
- 1 x 10,000 psi (700 bar) Hydraulic Hose, 2m (78.75")
- 1 x 300 mm (12") Vernier Calliper
- 1 x 12.5 mm (0.49") Spacer
- 1 x Safety Block
- 1 x Instruction Manual
- 1 x Carry-Case with Protective Foam Inserts

COLLETS (Available Separately):

- 2 x M76 (3") Collets
- 2 x M80 (3 1/4") Collets
- 2 x M84 (3 3/8") Collets
- 2 x M90 (3 1/2") Collets
- 2 x M95 (3 3/4") Collets
- 2 x M100 (4") Collets



Carry-Case Dimensions:

890 mm x 570 mm x 165 mm (35.0" x 22.4" x 6.5")

Gross Kit Weight: 48kg (105.6lbs)

Tool only weight: 21kg (46.2lbs)

## 6.3

### SG25TE DIMENSIONS

#### CLOSED DIMENSIONS



#### OPEN DIMENSIONS



#### SPREADING PLUG DIMENSIONS



# 7.

## TROUBLESHOOTING

### 7.1

#### SG18TE/ SG25TE TROUBLESHOOTING

HOSES ARE CONNECTED AND THE TOOL ADVANCES WITH MAXIMUM PRESSURE ON THE PUMP HANDLE BUT THE JOINT WILL NOT SPREAD

**POSSIBLE CAUSE:**

The pressure required to spread the joint is greater than that of the two tools you are using

**RECOMMENDED ACTION:**

Add another one or two tools and distribute them equally around the joint (120° apart with 3 tools and 90° apart with 4 tools) and try again.

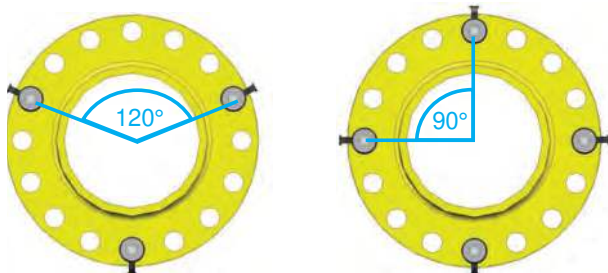

HOSES ARE CONNECTED BUT THE TOOL DOES NOT ADVANCE. THE PRESSURE ON THE PUMP HANDLE IS MINIMAL

**POSSIBLE CAUSE:**

The release valve is in the retract (open) position.

**RECOMMENDED ACTION:**

Close the release valve .

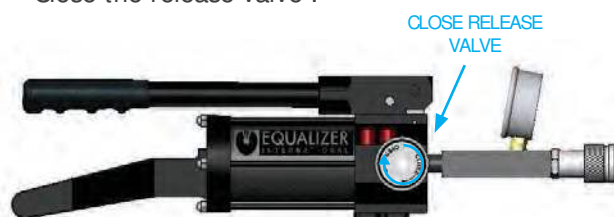

HOSES ARE CONNECTED AND THE PUMP QUICKLY REACHES MAXIMUM PRESSURE BUT THE TOOL HAS NOT ADVANCED

**POSSIBLE CAUSE:**

One or more of the connectors are not fully tightened and the hydraulic oil cannot pass through from the pump to the cylinder.

**RECOMMENDED ACTION:**

Check all connectors are fully tightened and the release valve is in the fully closed position.

HOSES ARE CONNECTED AND THE TOOL ADVANCES BUT THERE IS MINIMAL PRESSURE ON THE PUMP HANDLE; THE HANDLE IS RISING BACK OF ITS OWN ACCORD

**POSSIBLE CAUSE:**

There is dirt or a damaged valve seat within the pump unit.

**RECOMMENDED ACTION:**

The pump should be sent to an authorised Equalizer distributor for repair.

**ONE COLLET IS JAMMED IN A BOLT HOLE.**

**POSSIBLE CAUSE:**

A collet which is too small or large has been selected, or the collet has been inserted into a damaged or non-round bolt hole.

**RECOMMENDED ACTION:**

Removal can be achieved as follows:

If the jammed collet is on the collet holder:

1. Release all hydraulic pressure from the tool by turning the release valve anti-clockwise
2. Remove the hydraulic hose from the cylinder assembly
3. Unscrew the cylinder assembly from the collet holder
4. Unscrew the drive nut and remove the drive cone
5. Screw the drive nut back onto the collet holder until it is 1-2 mm off the end
6. Using a hammer and a suitable drift move the collet holder until the drive nut is against the flange
7. Remove the drive nut and push the collet holder through the flange and out of the other end of the bolt-hole
8. Drive the collet out using the spreading plug

If the jammed collet is on the collet spreading plug:

1. Unscrew the drive nut and remove the drive cone
2. Using a hammer and a suitable drift, drive the spreading plug out of the other end of the bolt-hole
3. Drive the collet out using the spreading plug

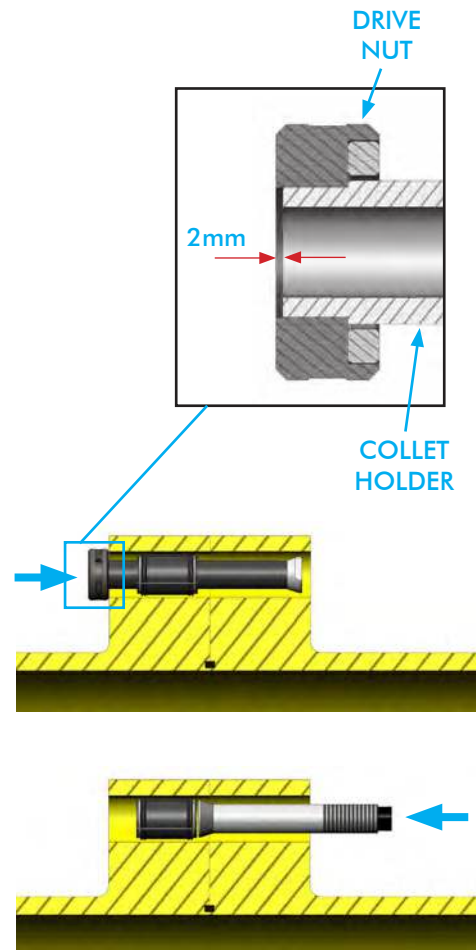

**A PAIR OF COLLETS, COMPLETE WITH THE SPREADING PLUG AND COLLET HOLDER, ARE JAMMED IN A BOLT HOLE**

**POSSIBLE CAUSE:**

A collet which is too small or large has been selected, or the collet has been inserted into a damaged or nonround bolt hole

**RECOMMENDED ACTION:**

The flange must be spread before removal can be attempted. This can be done using another two, three or four tools depending on the spreading force required. Removal can then be achieved as follows:

1. Release all hydraulic pressure from the tool by turning the release valve anti-clockwise
2. Remove the hydraulic hose from the cylinder assembly
3. Unscrew the cylinder assembly from the collet holder
4. Unscrew the drive nut and remove the drive cone from the collet holder
5. Screw the drive nut back onto the collet holder until it is 1-2mm off the end
6. Using a hammer and a suitable drift, move the collet holder until it is possible to cut off the tapered end of the collet holder
7. Cut off the tapered end of the collet holder with a hacksaw or other cutting tool
8. Withdraw the collet holder from the bolt hole
9. Unscrew the drive nut and remove the drive cone from the spreading plug
10. Using a hammer and a suitable drift, move the spreading plug up to the collet and drive it out
11. Drive the remaining collet out using the spreading plug

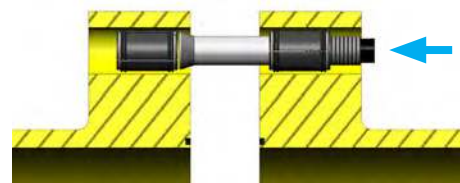
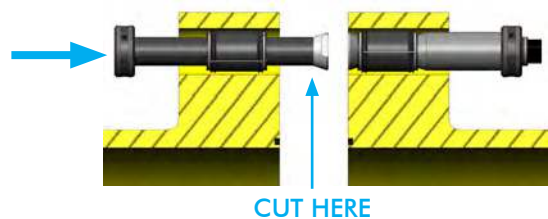

HOSES ARE CONNECTED AND THE TOOL ADVANCES AS THE PUMP IS PRIMED BUT THE PRESSURE ON THE PUMP HANDLE IS MINIMAL AND FEELS SPONGY

**POSSIBLE CAUSE:**

Air could be present in the hydraulic system.

**RECOMMENDED ACTION:**

Follow the airlock removal procedure:

1. Connect the hand pump to the tool with the hydraulic hose.
2. Close the release valve on the pump, and prime the pump until the hydraulic cylinder is fully extended and a small pressure is achieved
3. With the hand pump held above the tool and the tool in an upright position, open the release valve causing any air that is within the system to be forced up through the pump and vented into the oil reservoir
4. Repeat steps 1 - 3 three or four times to ensure that all air is removed from the system and the tool will reach full working pressure
5. Disconnect the hand pump from the hydraulic hose, grip the baseplate of the hand pump body in a vice with the pump body vertical and the main handle at the top
6. Remove the four nuts holding the main handle and lift off
7. Grip the refilling plug with pliers and extract it by pulling and twisting simultaneously. Ensure the reservoir body is held down when removing the refilling plug as pulling up on the reservoir body will release the bladder within, and oil will spill out.
8. Fill the reservoir to the top with a good quality hydraulic oil of the grade 15 cSt
9. Reinsert the refilling plug, wipe away any oil, and reassemble by reversing the disassembly process

**AIR LOCK REMOVAL PROCEDURE:**

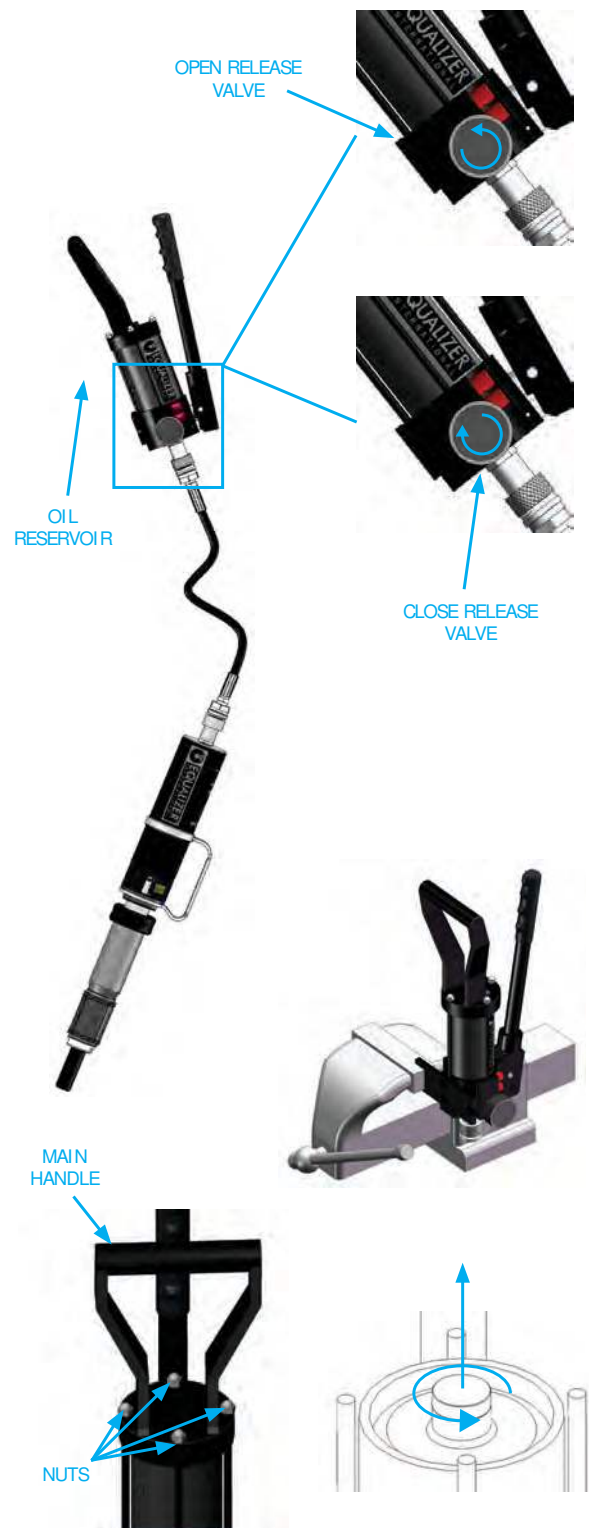

# 8.

## SECURE GRIP TOOL RANGE OF APPLICATION

Use the charts on the following pages to determine which Secure-Grip tool (and which collet size) is suitable for a particular flange.

The charts are categorised as per flange type.

Collet identification	Tool type	Operation type	SWL (ton)	Min. bolt-hole diameter	Max. bolt-hole diameter
M16 5/8"	SG4TM	manual	4	17.5	19.5
M20 3/4"	SG4TM	manual	4	20.5	23
M24 7/8"	SG6TM	manual	6	24	26.5
M27 1"	SG6TM	manual	6	27.5	30
M30 1 1/8"	SG11TM	manual	11	30	33
M33 1 1/4"	SG11TM	manual	11	32	36
M36 1 3/8"	SG11TM	manual	11	35	39
M39 1 1/2"	SG13TE	hydraulic	13	38	42
M42 1 5/8"	SG13TE	hydraulic	13	41	45
M45 1 3/4"	SG13TE	hydraulic	13	44	49
M48 1 7/8"	SG15TE	hydraulic	15	47.5	52
M52 2"	SG15TE	hydraulic	15	50.5	56
M56 2 1/4"	SG15TE	hydraulic	15	55.5	62
M60	SG18TE	in-line hydraulic	18	59.5	63
M64 2 1/2"	SG18TE	in-line hydraulic	18	63	69
M70 2 3/4"	SG18TE	in-line hydraulic	18	69	75
M76 3"	SG25TE	in-line hydraulic	25	75	81
M80 3 1/4"	SG25TE	in-line hydraulic	25	79	86
M84	SG25TE	in-line hydraulic	25	83	88
M90 3 1/2"	SG25TE	in-line hydraulic	25	88	94
M95 3 3/4"	SG25TE	in-line hydraulic	25	94	101
M100 4"	SG25TE	in-line hydraulic	25	99	107

SPO		→	see page 26
ANSI	compact	→	see page 27
	orifice	→	see page 27
	reducing	→	see page 28
DIN	blind	→	see page 29
	threaded	→	see page 29
	weldneck	→	see page 30
	flat	→	see page 30
	lapped	→	see page 30
ASME	series A weld neck	→	see page 31
	series A lapped	→	see page 32
	series A socket welded	→	see page 32
	series B weld neck and blind	→	see page 32
API	6B weld neck	→	see page 33
	6B blind and threaded	→	see page 33
	6BX weld neck	→	see page 33
	6BX blind and test	→	see page 33
BS		→	see page 34



SPO FLANGES

Nominal pipe size	Class													
	150		300		600		900		1500		2500		4500i	
	collet	tool	collet	tool	collet	tool	collet	tool	collet	tool	collet	tool	collet	tool
1 1/2"													M16 5/8"	SG4TM
2"													M16 5/8"	SG4TM
2 1/2"													M20 3/4"	SG4TM
3"													M16 5/8"	SG4TM
4"					M16 5/8"	SG4TM	M16 5/8"	SG4TM	M20 3/4"	SG4TM	M27 1"	SG6TM	M24 7/8"	SG6TM
5"					M16 5/8"	SG4TM	M16 5/8"	SG4TM	M24 7/8"	SG6TM	M27 1"	SG6TM	M30 1 1/8"	SG11TM
6"					M16 5/8"	SG4TM	M16 5/8"	SG4TM	M27 1"	SG6TM	M30 1 1/8"	SG11TM	M33 1 1/4"	SG11TM
8"			M16 5/8"	SG4TM	M16 5/8"	SG4TM	M20 3/4"	SG4TM	M27 1"	SG6TM	M36 1 3/8"	SG11TM	M39 1 1/2"	SG13TE
10"			M16 5/8"	SG4TM	M20 3/4"	SG4TM	M24 7/8"	SG6TM	M33 1 1/4"	SG11TM	M39 1 1/2"	SG13TE	M48 1 7/8"	SG15TE
12"			M16 5/8"	SG4TM	M24 7/8"	SG6TM	M27 1"	SG6TM	M33 1 1/4"	SG11TM	M45 1 3/4"	SG13TE	M48 1 7/8"	SG15TE
14"			M16 5/8"	SG4TM	M24 7/8"	SG6TM	M27 1"	SG6TM	M36 1 3/8"	SG11TM	M48 1 7/8"	SG15TE	M52 2"	SG15TE
16"	M16 5/8"	SG4TM	M20 3/4"	SG4TM	M27 1"	SG6TM	M30 1 1/8"	SG11TM	M39 1 1/2"	SG13TE	M60	SG18TE	M60	SG18TE
18"	M16 5/8"	SG4TM	M20 3/4"	SG4TM	M30 1 1/8"	SG11TM	M33 1 1/4"	SG11TM	M45 1 3/4"	SG13TE	M60	SG18TE	M64 2 1/2"	SG18TE
20"	M16 5/8"	SG4TM	M24 7/8"	SG6TM	M30 1 1/8"	SG11TM	M36 1 3/8"	SG11TM	M48 1 7/8"	SG15TE	M64 2 1/2"	SG18TE	M84	SG25TE
22"	M16 5/8"	SG4TM	M24 7/8"	SG6TM	M33 1 1/4"	SG11TM	M39 1 1/2"	SG13TE	M52 2"	SG15TE	M76 3"	SG25TE	M90 3 1/2"	SG25TE
24"	M20 3/4"	SG4TM	M27 1"	SG6TM	M33 1 1/4"	SG11TM	M42 1 5/8"	SG13TE	M60	SG18TE	M84	SG25TE	M100 4"	SG25TE
26"	M20 3/4"	SG4TM	M27 1"	SG6TM	M33 1 1/4"	SG11TM	M45 1 3/4"	SG13TE	M60	SG18TE				
28"	M20 3/4"	SG4TM	M27 1"	SG6TM	M36 1 3/8"	SG11TM	M45 1 3/4"	SG13TE	M60	SG18TE				
30"	M20 3/4"	SG4TM	M30 1 1/8"	SG11TM	M36 1 3/8"	SG11TM	M48 1 7/8"	SG15TE	M64 2 1/2"	SG18TE				
32"	M20 3/4"	SG4TM	M30 1 1/8"	SG11TM	M39 1 1/2"	SG13TE	M52 2"	SG15TE	M64 2 1/2"	SG18TE				
34"	M20 3/4"	SG4TM	M33 1 1/4"	SG11TM	M39 1 1/2"	SG13TE	M60	SG18TE	M70 2 3/4"	SG18TE				
36"	M24 7/8"	SG6TM	M33 1 1/4"	SG11TM	M39 1 1/2"	SG13TE	M60	SG18TE	M84	SG25TE				
38"	M24 7/8"	SG6TM	M33 1 1/4"	SG11TM	M39 1 1/2"	SG13TE	M64 2 1/2"	SG18TE	M90 3 1/2"	SG25TE				
40"	M24 7/8"	SG6TM	M33 1 1/4"	SG11TM	M39 1 1/2"	SG13TE	M64 2 1/2"	SG18TE	M84	SG25TE				
42"	M24 7/8"	SG6TM	M36 1 3/8"	SG11TM	M48 1 7/8"	SG15TE	M64 2 1/2"	SG18TE	M95 3 3/4"	SG25TE				
44"	M24 7/8"	SG6TM	M36 1 3/8"	SG11TM	M48 1 7/8"	SG15TE	M64 2 1/2"	SG18TE	M95 3 3/4"	SG25TE				
46"	M24 7/8"	SG6TM	M39 1 1/2"	SG13TE	M48 1 7/8"	SG15TE	M70 2 3/4"	SG18TE	M95 3 3/4"	SG25TE				
48"	M24 7/8"	SG6TM	M39 1 1/2"	SG13TE	M48 1 7/8"	SG15TE	M76 3"	SG25TE	M95 3 3/4"	SG25TE				

## ANSI COMPACT

Nominal pipe size	Class									
	300		600		900		1500		2500	
	collet	tool	collet	tool	collet	tool	collet	tool	collet	tool
1"	no flange		no flange		no flange		no flange		no flange	
1 1/2"										
2"									M16 5/8"	SG4TM
2 1/2"	M16 5/8"	SG4TM	M16 5/8"	SG4TM	M16 5/8"	SG4TM	M16 5/8"	SG4TM	M24 7/8"	SG6TM
3"	M16 5/8"	SG4TM	M16 5/8"	SG4TM	M16 5/8"	SG4TM	M16 5/8"	SG4TM	M16 5/8"	SG4TM
4"	M20 3/4"	SG4TM	M20 3/4"	SG4TM	M20 3/4"	SG4TM	M20 3/4"	SG4TM	M20 3/4"	SG4TM
5"	M20 3/4"	SG4TM	M20 3/4"	SG4TM	M20 3/4"	SG4TM	M20 3/4"	SG4TM	M27 1"	SG6TM
6"	M20 3/4"	SG4TM	M20 3/4"	SG4TM	M20 3/4"	SG4TM	M24 7/8"	SG6TM	M30 1 1/8"	SG11TM
8"	M20 3/4"	SG4TM	M20 3/4"	SG4TM	M20 3/4"	SG4TM	M27 1"	SG6TM	M36 1 3/8"	SG11TM
10"	M20 3/4"	SG4TM	M20 3/4"	SG4TM	M27 1"	SG6TM	M30 1 1/8"	SG11TM	M45 1 3/4"	SG13TE
12"	M20 3/4"	SG4TM	M24 7/8"	SG6TM	M30 1 1/8"	SG11TM	M36 1 3/8"	SG11TM	M52 2"	SG15TE
14"	M20 3/4"	SG4TM	M27 1"	SG6TM	M33 1 1/4"	SG11TM	M36 1 3/8"	SG11TM	M45 1 3/4"	SG13TE
16"	M20 3/4"	SG4TM	M30 1 1/8"	SG11TM	M36 1 3/8"	SG11TM	M42 1 5/8"	SG13TE	M52 2"	SG15TE
18"	M24 7/8"	SG6TM	M33 1 1/4"	SG11TM	M36 1 3/8"	SG11TM	M45 1 3/4"	SG13TE	M56 2 1/4"	SG15TE
20"	M30 1 1/8"	SG11TM	M36 1 3/8"	SG11TM	M39 1 1/2"	SG13TE	M52 2"	SG15TE	M64 2 1/2"	SG18TE
24"	M30 1 1/8"	SG11TM	M39 1 1/2"	SG13TE	M45 1 3/4"	SG13TE	M56 2 1/4"	SG15TE	M64 2 1/2"	SG18TE
30"	M27 1"	SG6TM	M42 1 5/8"	SG13TE	M56 2 1/4"	SG15TE	M70 2 3/4"	SG18TE		
36"	M30 1 1/8"	SG11TM	M45 1 3/4"	SG13TE	M56 2 1/4"	SG15TE	M76 3"	SG25TE		
40"	M30 1 1/8"	SG11TM	M52 2"	SG15TE	M64 2 1/2"	SG18TE	M84	SG25TE		

## ANSI ORIFICE

Nominal pipe size	Class											
	300		400		600		900		1500		2500	
	collet	tool	collet	tool	collet	tool	collet	tool	collet	tool		
1"	M16 5/8"	SG4TM	M16 5/8"	SG4TM	M16 5/8"	SG4TM	M24 7/8"	SG6TM	M24 7/8"	SG6TM	M24 7/8"	SG6TM
1 1/2"	M20 3/4"	SG4TM	M20 3/4"	SG4TM	M20 3/4"	SG4TM	M27 1"	SG6TM	M27 1"	SG6TM	M30 1 1/8"	SG11TM
2"	M16 5/8"	SG4TM	M16 5/8"	SG4TM	M16 5/8"	SG4TM	M24 7/8"	SG6TM	M24 7/8"	SG6TM	M27 1"	SG6TM
2 1/2"	M20 3/4"	SG4TM	M20 3/4"	SG4TM	M20 3/4"	SG4TM	M27 1"	SG6TM	M27 1"	SG6TM	M30 1 1/8"	SG11TM
3"	M20 3/4"	SG4TM	M20 3/4"	SG4TM	M20 3/4"	SG4TM	M24 7/8"	SG6TM	M30 1 1/8"	SG11TM	M33 1 1/4"	SG11TM
4"	M20 3/4"	SG4TM	M24 7/8"	SG6TM	M24 7/8"	SG6TM	M30 1 1/8"	SG11TM	M33 1 1/4"	SG11TM	M39 1 1/2"	SG13TE
6"	M20 3/4"	SG4TM	M24 7/8"	SG6TM	M27 1"	SG6TM	M30 1 1/8"	SG11TM	M36 1 3/8"	SG11TM	M52 2"	SG15TE
8"	M24 7/8"	SG6TM	M27 1"	SG6TM	M30 1 1/8"	SG11TM	M36 1 3/8"	SG11TM	M42 1 5/8"	SG13TE	M52 2"	SG15TE
10"	M27 1"	SG6TM	M30 1 1/8"	SG11TM	M33 1 1/4"	SG11TM	M36 1 3/8"	SG11TM	M48 1 7/8"	SG15TE	M64 2 1/2"	SG18TE
12"	M30 1 1/8"	SG11TM	M33 1 1/4"	SG11TM	M33 1 1/4"	SG11TM	M36 1 3/8"	SG11TM	M52 2"	SG15TE	M70 2 3/4"	SG18TE
14"	M30 1 1/8"	SG11TM	M33 1 1/4"	SG11TM	M36 1 3/8"	SG11TM	M39 1 1/2"	SG13TE	M56 2 1/4"	SG15TE		
16"	M33 1 1/4"	SG11TM	M36 1 3/8"	SG11TM	M39 1 1/2"	SG13TE	M42 1 5/8"	SG13TE	M64 2 1/2"	SG18TE		
18"	M33 1 1/4"	SG11TM	M36 1 3/8"	SG11TM	M42 1 5/8"	SG13TE	M48 1 7/8"	SG15TE	M70 2 3/4"	SG18TE		
20"	M33 1 1/4"	SG11TM	M39 1 1/2"	SG13TE	M42 1 5/8"	SG13TE	M52 2"	SG15TE	M76 3"	SG25TE		
24"	M39 1 1/2"	SG13TE	M45 1 3/4"	SG13TE	M48 1 7/8"	SG15TE	M64 2 1/2"	SG18TE	M90 3 1/2"	SG25TE		

## ANSI REDUCING

Nominal pipe size	Class													
	150		300		400		600		900		1500		2500	
	collet	tool	collet	tool	collet	tool	collet	tool	collet	tool	collet	tool	collet	tool
1/2"									M20 3/4"	SG4TM	M20 3/4"	SG4TM	M20 3/4"	SG4TM
3/4"			M16 5/8"	SG4TM	M16 5/8"	SG4TM	M16 5/8"	SG4TM	M20 3/4"	SG4TM	M20 3/4"	SG4TM	M20 3/4"	SG4TM
1"			M16 5/8"	SG4TM	M16 5/8"	SG4TM	M16 5/8"	SG4TM	M24 7/8"	SG6TM	M24 7/8"	SG6TM	M24 7/8"	SG6TM
1 1/4"			M16 5/8"	SG4TM	M16 5/8"	SG4TM	M16 5/8"	SG4TM	M24 7/8"	SG6TM	M24 7/8"	SG6TM	M27 1"	SG6TM
1 1/2"			M20 3/4"	SG4TM	M20 3/4"	SG4TM	M20 3/4"	SG4TM	M27 1"	SG6TM	M27 1"	SG6TM	M30 1 1/8"	SG11TM
2"	M16 5/8"	SG4TM	M16 5/8"	SG4TM	M16 5/8"	SG4TM	M16 5/8"	SG4TM	M24 7/8"	SG6TM	M24 7/8"	SG6TM	M27 1"	SG6TM
2 1/2"	M16 5/8"	SG4TM	M20 3/4"	SG4TM	M20 3/4"	SG4TM	M20 3/4"	SG4TM	M27 1"	SG6TM	M27 1"	SG6TM	M30 1 1/8"	SG11TM
3"	M16 5/8"	SG4TM	M20 3/4"	SG4TM	M20 3/4"	SG4TM	M20 3/4"	SG4TM	M24 7/8"	SG6TM	M30 1 1/8"	SG11TM	M33 1 1/4"	SG11TM
3 1/2"	M16 5/8"	SG4TM	M20 3/4"	SG4TM	M24 7/8"	SG6TM	M24 7/8"	SG6TM	no flange		no flange		no flange	
4"	M16 5/8"	SG4TM	M20 3/4"	SG4TM	M24 7/8"	SG6TM	M24 7/8"	SG6TM	M30 1 1/8"	SG11TM	M33 1 1/4"	SG11TM	M39 1 1/2"	SG13TE
5"	M20 3/4"	SG4TM	M20 3/4"	SG4TM	M24 7/8"	SG6TM	M27 1"	SG6TM	M33 1 1/4"	SG11TM	M39 1 1/2"	SG13TE	M45 1 3/4"	SG13TE
6"	M20 3/4"	SG4TM	M20 3/4"	SG4TM	M24 7/8"	SG6TM	M27 1"	SG6TM	M30 1 1/8"	SG11TM	M36 1 3/8"	SG11TM	M52 2"	SG15TE
8"	M20 3/4"	SG4TM	M24 7/8"	SG6TM	M27 1"	SG6TM	M30 1 1/8"	SG11TM	M36 1 3/8"	SG11TM	M42 1 5/8"	SG13TE	M52 2"	SG15TE
10"	M24 7/8"	SG6TM	M27 1"	SG6TM	M30 1 1/8"	SG11TM	M33 1 1/4"	SG11TM	M36 1 3/8"	SG11TM	M48 1 7/8"	SG15TE	M64 2 1/2"	SG18TE
12"	M24 7/8"	SG6TM	M30 1 1/8"	SG11TM	M33 1 1/4"	SG11TM	M33 1 1/4"	SG11TM	M36 1 3/8"	SG11TM	M52 2"	SG15TE	M70 2 3/4"	SG18TE
14"	M27 1"	SG6TM	M30 1 1/8"	SG11TM	M33 1 1/4"	SG11TM	M36 1 3/8"	SG11TM	M39 1 1/2"	SG13TE	M56 2 1/4"	SG15TE		
16"	M27 1"	SG6TM	M33 1 1/4"	SG11TM	M36 1 3/8"	SG11TM	M39 1 1/2"	SG13TE	M42 1 5/8"	SG13TE	M64 2 1/2"	SG18TE		
18"	M30 1 1/8"	SG11TM	M33 1 1/4"	SG11TM	M36 1 3/8"	SG11TM	M42 1 5/8"	SG13TE	M48 1 7/8"	SG15TE	M70 2 3/4"	SG18TE		
20"	M30 1 1/8"	SG11TM	M33 1 1/4"	SG11TM	M39 1 1/2"	SG13TE	M42 1 5/8"	SG13TE	M52 2"	SG15TE	M76 3"	SG25TE		
22"	no flange		no flange		no flange		no flange		no flange		no flange			
24"	M33 1 1/4"	SG11TM	M39 1 1/2"	SG13TE	M45 1 3/4"	SG13TE	M48 1 7/8"	SG15TE	M64 2 1/2"	SG18TE	M90 3 1/2"	SG25TE		
26"	M33 1 1/4"	SG11TM	M42 1 5/8"	SG13TE	M42 1 5/8"	SG13TE	M48 1 7/8"	SG15TE	M70 2 3/4"	SG18TE				
28"	M33 1 1/4"	SG11TM	M42 1 5/8"	SG13TE	M42 1 5/8"	SG13TE	M52 2"	SG15TE	M76 3"	SG25TE				
30"	M33 1 1/4"	SG11TM	M45 1 3/4"	SG13TE	M45 1 3/4"	SG13TE	M56 2 1/4"	SG15TE	M76 3"	SG25TE				
32"	M39 1 1/2"	SG13TE	M48 1 7/8"	SG15TE	M48 1 7/8"	SG15TE	M56 2 1/4"	SG15TE	M84	SG25TE				
34"	M39 1 1/2"	SG13TE	M48 1 7/8"	SG15TE	M48 1 7/8"	SG15TE	M56 2 1/4"	SG15TE	M90 3 1/2"	SG25TE				
36"	M39 1 1/2"	SG13TE	M52 2"	SG15TE	M52 2"	SG15TE	M56 2 1/4"	SG15TE	M90 3 1/2"	SG25TE				
38"	M39 1 1/2"	SG13TE	M39 1 1/2"	SG13TE	M39 1 1/2"	SG13TE	M56 2 1/4"	SG15TE	M90 3 1/2"	SG25TE				
40"	M39 1 1/2"	SG13TE	M42 1 5/8"	SG13TE	M42 1 5/8"	SG13TE	M56 2 1/4"	SG15TE	M90 3 1/2"	SG25TE				
42"	M39 1 1/2"	SG13TE	M42 1 5/8"	SG13TE	M42 1 5/8"	SG13TE	M56 2 1/4"	SG15TE	M90 3 1/2"	SG25TE				
44"	M39 1 1/2"	SG13TE	M45 1 3/4"	SG13TE	M45 1 3/4"	SG13TE	M56 2 1/4"	SG15TE	M95 3 3/4"	SG25TE				
46"	M39 1 1/2"	SG13TE	M48 1 7/8"	SG15TE	M48 1 7/8"	SG15TE	M56 2 1/4"	SG15TE	M100 4"	SG25TE				
48"	M39 1 1/2"	SG13TE	M48 1 7/8"	SG15TE	M48 1 7/8"	SG15TE	M70 2 3/4"	SG18TE	M100 4"	SG25TE				

DIN BLIND

Nominal pipe size	Class									
	PN16		PN25		PN40		PN64		PN100	
	collet	tool	collet	tool	collet	tool	collet	tool	collet	tool
3/4"							no flange		no flange	
1"							M16 5/8"	SG4TM	M16 5/8"	SG4TM
1 1/4"	M16 5/8"	SG4TM	M16 5/8"	SG4TM	M16 5/8"	SG4TM	M20 3/4"	SG4TM	M20 3/4"	SG4TM
1 1/2"	M16 5/8"	SG4TM	M16 5/8"	SG4TM	M16 5/8"	SG4TM	M20 3/4"	SG4TM	M20 3/4"	SG4TM
2"	M16 5/8"	SG4TM	M16 5/8"	SG4TM	M16 5/8"	SG4TM	M20 3/4"	SG4TM	M24 7/8"	SG6TM
2 1/2"	M16 5/8"	SG4TM	M16 5/8"	SG4TM	M16 5/8"	SG4TM	M20 3/4"	SG4TM	M24 7/8"	SG6TM
3"	M16 5/8"	SG4TM	M16 5/8"	SG4TM	M16 5/8"	SG4TM	M20 3/4"	SG4TM	M24 7/8"	SG6TM
4"	M16 5/8"	SG4TM	M20 3/4"	SG4TM	M20 3/4"	SG4TM	M24 7/8"	SG6TM	M27 1"	SG6TM
5"	M16 5/8"	SG4TM	M24 7/8"	SG6TM	M24 7/8"	SG6TM	M27 1"	SG6TM	M30 1 1/8"	SG11TM
6"	M20 3/4"	SG4TM	M24 7/8"	SG6TM	M24 7/8"	SG6TM	M30 1 1/8"	SG11TM	M30 1 1/8"	SG11TM
7"	M20 3/4"	SG4TM	M24 7/8"	SG6TM	M27 1"	SG6TM	M30 1 1/8"	SG11TM	M30 1 1/8"	SG11TM
8"	M20 3/4"	SG4TM	M24 7/8"	SG6TM	M27 1"	SG6TM	M33 1 1/4"	SG11TM	M33 1 1/4"	SG11TM
10"	M24 7/8"	SG6TM	M27 1"	SG6TM	M30 1 1/8"	SG11TM	M33 1 1/4"	SG11TM	M36 1 3/8"	SG11TM
12"	M24 7/8"	SG6TM	M27 1"	SG6TM	M30 1 1/8"	SG11TM	M33 1 1/4"	SG11TM	M39 1 1/2"	SG13TE
14"	M24 7/8"	SG6TM	M30 1 1/8"	SG11TM	M33 1 1/4"	SG11TM	M36 1 3/8"	SG11TM	M45 1 3/4"	SG13TE
16"	M27 1"	SG6TM	M33 1 1/4"	SG11TM	M36 1 3/8"	SG11TM	M39 1 1/2"	SG13TE		
20"	M30 1 1/8"	SG11TM	M33 1 1/4"	SG11TM	M39 1 1/2"	SG13TE				

DIN THREADED

Nominal pipe size	Class									
	PN16		PN25		PN40		PN64		PN100	
	collet	tool	collet	tool	collet	tool	collet	tool	collet	tool
3/4"									M16 5/8"	SG4TM
1"									M16 5/8"	SG4TM
1 1/4"	M16 5/8"	SG4TM	M16 5/8"	SG4TM	M16 5/8"	SG4TM	M16 5/8"	SG4TM	M20 3/4"	SG4TM
1 1/2"	M16 5/8"	SG4TM	M16 5/8"	SG4TM	M16 5/8"	SG4TM	M16 5/8"	SG4TM	M20 3/4"	SG4TM
2"	M16 5/8"	SG4TM	M16 5/8"	SG4TM	M16 5/8"	SG4TM	M20 3/4"	SG4TM	M24 7/8"	SG6TM
2 1/2"	M16 5/8"	SG4TM	M16 5/8"	SG4TM	M16 5/8"	SG4TM	M20 3/4"	SG4TM	M24 7/8"	SG6TM
3"	M16 5/8"	SG4TM	M16 5/8"	SG4TM	M16 5/8"	SG4TM	M20 3/4"	SG4TM	M24 7/8"	SG6TM
4"	M16 5/8"	SG4TM	M20 3/4"	SG4TM	M20 3/4"	SG4TM	M24 7/8"	SG6TM	M27 1"	SG6TM
5"	M16 5/8"	SG4TM	M24 7/8"	SG6TM	M24 7/8"	SG6TM	M24 7/8"	SG6TM	M30 1 1/8"	SG11TM
6"	M16 5/8"	SG4TM	M24 7/8"	SG6TM	M24 7/8"	SG6TM	M30 1 1/8"	SG11TM	M30 1 1/8"	SG11TM

**DIN WELDNECK**

Nominal pipe size	Class											
	PN16		PN25		PN40		PN64		PN100		PN160	
	collet	tool	collet	tool	collet	tool	collet	tool	collet	tool	collet	tool
1"							M16 5/8"	SG4TM	M16 5/8"	SG4TM	M16 5/8"	SG4TM
1 1/4"	M16 5/8"	SG4TM	M16 5/8"	SG4TM	M16 5/8"	SG4TM						
1 1/2"	M16 5/8"	SG4TM	M16 5/8"	SG4TM	M16 5/8"	SG4TM	M20 3/4"	SG4TM	M20 3/4"	SG4TM	M20 3/4"	SG4TM
2"	M16 5/8"	SG4TM	M16 5/8"	SG4TM	M16 5/8"	SG4TM	M20 3/4"	SG4TM	M24 7/8"	SG6TM	M24 7/8"	SG6TM
2 1/2"	M16 5/8"	SG4TM	M16 5/8"	SG4TM	M16 5/8"	SG4TM	M20 3/4"	SG4TM	M24 7/8"	SG6TM	M24 7/8"	SG6TM
3"	M16 5/8"	SG4TM	M16 5/8"	SG4TM	M16 5/8"	SG4TM	M20 3/4"	SG4TM	M24 7/8"	SG6TM	M24 7/8"	SG6TM
4"	M16 5/8"	SG4TM	M16 5/8"	SG4TM	M16 5/8"	SG4TM	M24 7/8"	SG6TM	M27 1"	SG6TM	M27 1"	SG6TM
5"	M16 5/8"	SG4TM	M16 5/8"	SG4TM	M16 5/8"	SG4TM	M27 1"	SG6TM	M30 1 1/8"	SG11TM	M30 1 1/8"	SG11TM
6"	M20 3/4"	SG4TM	M20 3/4"	SG4TM	M20 3/4"	SG4TM	M30 1 1/8"	SG11TM	M30 1 1/8"	SG11TM	M30 1 1/8"	SG11TM
7"	M20 3/4"	SG4TM	M24 7/8"	SG6TM	M20 3/4"	SG4TM	M30 1 1/8"	SG11TM	M30 1 1/8"	SG11TM	M33 1 1/4"	SG11TM
8"	M20 3/4"	SG4TM	M24 7/8"	SG6TM	M20 3/4"	SG4TM	M33 1 1/4"	SG11TM	M33 1 1/4"	SG11TM	M33 1 1/4"	SG11TM
10"	M24 7/8"	SG6TM	M27 1"	SG6TM	M24 7/8"	SG6TM	M33 1 1/4"	SG11TM	M36 1 3/8"	SG11TM	M39 1 1/2"	SG13TE
12"	M24 7/8"	SG6TM	M27 1"	SG6TM	M24 7/8"	SG6TM	M33 1 1/4"	SG11TM	M39 1 1/2"	SG13TE	M39 1 1/2"	SG13TE
14"	M24 7/8"	SG6TM	M30 1 1/8"	SG11TM	M24 7/8"	SG6TM	M36 1 3/8"	SG11TM	M45 1 3/4"	SG13TE		
16"	M27 1"	SG6TM	M33 1 1/4"	SG11TM	M27 1"	SG6TM	M39 1 1/2"	SG13TE				
18"	M27 1"	SG6TM	M33 1 1/4"	SG11TM	M27 1"	SG6TM						
20"	M30 1 1/8"	SG11TM	M33 1 1/4"	SG11TM	M30 1 1/8"	SG11TM						
24"	M33 1 1/4"	SG11TM	M36 1 3/8"	SG11TM								
28"	M33 1 1/4"	SG11TM	M39 1 1/2"	SG13TE								
32"	M36 1 3/8"	SG11TM	M45 1 3/4"	SG13TE								
36"	M36 1 3/8"	SG11TM	M45 1 3/4"	SG13TE								
40"	M39 1 1/2"	SG13TE	M52 2"	SG15TE								
48"	M45 1 3/4"	SG13TE										
56"	M45 1 3/4"	SG13TE										
64"	M52 2"	SG15TE										
72"	M52 2"	SG15TE										
80"	M56 2 1/4"	SG15TE										

**DIN FLAT**

Nominal pipe size	Class			
	PN6		PN10	
	collet	tool	collet	tool
1 1/4"			M16 5/8"	SG4TM
1 1/2"			M16 5/8"	SG4TM
2"			M16 5/8"	SG4TM
2 1/2"			M16 5/8"	SG4TM
3"	M16 5/8"	SG4TM	M16 5/8"	SG4TM
4"	M16 5/8"	SG4TM	M16 5/8"	SG4TM
5"	M16 5/8"	SG4TM	M16 5/8"	SG4TM
6"	M16 5/8"	SG4TM	M20 3/4"	SG4TM
8"	M16 5/8"	SG4TM	M20 3/4"	SG4TM
10"	M16 5/8"	SG4TM	M20 3/4"	SG4TM
12"	M20 3/4"	SG4TM	M20 3/4"	SG4TM
14"	M20 3/4"	SG4TM	M20 3/4"	SG4TM
16"	M20 3/4"	SG4TM	M24 7/8"	SG6TM
18"	M20 3/4"	SG4TM	M24 7/8"	SG6TM
20"	M20 3/4"	SG4TM	M24 7/8"	SG6TM

**DIN LAPPED**

Nominal pipe size	Class			
	PN6		PN10	
	collet	tool	collet	tool
1 1/4"			M16 5/8"	SG4TM
1 1/2"			M16 5/8"	SG4TM
2"			M16 5/8"	SG4TM
2 1/2"			M16 5/8"	SG4TM
3"	M16 5/8"	SG4TM	M16 5/8"	SG4TM
4"	M16 5/8"	SG4TM	M16 5/8"	SG4TM
5"	M16 5/8"	SG4TM	M16 5/8"	SG4TM
6"	M16 5/8"	SG4TM	M20 3/4"	SG4TM
8"	M16 5/8"	SG4TM	M20 3/4"	SG4TM
10"	M16 5/8"	SG4TM	M20 3/4"	SG4TM
12"	M20 3/4"	SG4TM	M20 3/4"	SG4TM
14"	M20 3/4"	SG4TM	M20 3/4"	SG4TM
16"	M20 3/4"	SG4TM	M24 7/8"	SG6TM
18"	M20 3/4"	SG4TM	M24 7/8"	SG6TM
20"	M20 3/4"	SG4TM	M24 7/8"	SG6TM
24"	M24 7/8"	SG6TM	M27 1"	SG6TM
28"	M24 7/8"	SG6TM	M27 1"	SG6TM
32"	M27 1"	SG6TM	M30 1 1/8"	SG11TM
36"	M27 1"	SG6TM		
40"	M27 1"	SG6TM		

ASME SERIES A WELD NECK

Nominal pipe size	Class													
	150		300		400		600		900		1500		2500	
	collet	tool	collet	tool	collet	tool	collet	tool	collet	tool	collet	tool	collet	tool
1/2"									M20 3/4"	SG4TM	M20 3/4"	SG4TM	M20 3/4"	SG4TM
3/4"			M16 5/8"	SG4TM	M16 5/8"	SG4TM	M16 5/8"	SG4TM	M20 3/4"	SG4TM	M20 3/4"	SG4TM	M20 3/4"	SG4TM
1"			M16 5/8"	SG4TM	M16 5/8"	SG4TM	M16 5/8"	SG4TM	M24 7/8"	SG6TM	M24 7/8"	SG6TM	M24 7/8"	SG6TM
1 1/4"			M16 5/8"	SG4TM	M16 5/8"	SG4TM	M16 5/8"	SG4TM	M24 7/8"	SG6TM	M24 7/8"	SG6TM	M27 1"	SG6TM
1 1/2"			M20 3/4"	SG4TM	M20 3/4"	SG4TM	M20 3/4"	SG4TM	M27 1"	SG6TM	M27 1"	SG6TM	M30 1 1/8"	SG11TM
2"	M16 5/8"	SG4TM	M16 5/8"	SG4TM	M16 5/8"	SG4TM	M16 5/8"	SG4TM	M24 7/8"	SG6TM	M24 7/8"	SG6TM	M27 1"	SG6TM
2 1/2"	M16 5/8"	SG4TM	M20 3/4"	SG4TM	M20 3/4"	SG4TM	M20 3/4"	SG4TM	M24 7/8"	SG6TM	M27 1"	SG6TM	M30 1 1/8"	SG11TM
3"	M16 5/8"	SG4TM	M20 3/4"	SG4TM	M20 3/4"	SG4TM	M20 3/4"	SG4TM	M24 7/8"	SG6TM	M30 1 1/8"	SG11TM	M33 1 1/4"	SG11TM
3 1/2"	M16 5/8"	SG4TM	M20 3/4"	SG4TM	M24 7/8"	SG6TM	M24 7/8"	SG6TM						
4"	M16 5/8"	SG4TM	M20 3/4"	SG4TM	M24 7/8"	SG6TM	M24 7/8"	SG6TM	M30 1 1/8"	SG11TM	M33 1 1/4"	SG11TM	M39 1 1/2"	SG13TE
5"	M20 3/4"	SG4TM	M20 3/4"	SG4TM	M24 7/8"	SG6TM	M27 1"	SG6TM	M33 1 1/4"	SG11TM	M39 1 1/2"	SG13TE	M45 1 3/4"	SG13TE
6"	M20 3/4"	SG4TM	M20 3/4"	SG4TM	M24 7/8"	SG6TM	M27 1"	SG6TM	M30 1 1/8"	SG11TM	M36 1 3/8"	SG11TM	M52 2"	SG15TE
8"	M20 3/4"	SG4TM	M24 7/8"	SG6TM	M27 1"	SG6TM	M30 1 1/8"	SG11TM	M36 1 3/8"	SG11TM	M42 1 5/8"	SG13TE	M52 2"	SG15TE
10"	M24 7/8"	SG6TM	M27 1"	SG6TM	M30 1 1/8"	SG11TM	M33 1 1/4"	SG11TM	M36 1 3/8"	SG11TM	M48 1 7/8"	SG15TE	M64 2 1/2"	SG18TE
12"	M24 7/8"	SG6TM	M30 1 1/8"	SG11TM	M33 1 1/4"	SG11TM	M33 1 1/4"	SG11TM	M36 1 3/8"	SG11TM	M52 2"	SG15TE	M70 2 3/4"	SG18TE
14"	M27 1"	SG6TM	M30 1 1/8"	SG11TM	M33 1 1/4"	SG11TM	M36 1 3/8"	SG11TM	M39 1 1/2"	SG13TE	M56 2 1/4"	SG15TE		
16"	M27 1"	SG6TM	M33 1 1/4"	SG11TM	M36 1 3/8"	SG11TM	M39 1 1/2"	SG13TE	M42 1 5/8"	SG13TE	M64 2 1/2"	SG18TE		
18"	M30 1 1/8"	SG11TM	M33 1 1/4"	SG11TM	M36 1 3/8"	SG11TM	M42 1 5/8"	SG13TE	M48 1 7/8"	SG15TE	M70 2 3/4"	SG18TE		
20"	M30 1 1/8"	SG11TM	M33 1 1/4"	SG11TM	M39 1 1/2"	SG13TE	M42 1 5/8"	SG13TE	M52 2"	SG15TE	M76 3"	SG25TE		
22"														
24"	M33 1 1/4"	SG11TM	M39 1 1/2"	SG13TE	M45 1 3/4"	SG13TE	M48 1 7/8"	SG15TE	M64 2 1/2"	SG18TE	M90 3 1/2"	SG25TE		
26"	M33 1 1/4"	SG11TM	M42 1 5/8"	SG13TE	M42 1 5/8"	SG13TE	M48 1 7/8"	SG15TE	M70 2 3/4"	SG18TE				
28"	M33 1 1/4"	SG11TM	M42 1 5/8"	SG13TE	M42 1 5/8"	SG13TE	M52 2"	SG15TE	M76 3"	SG25TE				
30"	M33 1 1/4"	SG11TM	M45 1 3/4"	SG13TE	M45 1 3/4"	SG13TE	M56 2 1/4"	SG15TE	M76 3"	SG25TE				
32"	M39 1 1/2"	SG13TE	M48 1 7/8"	SG15TE	M48 1 7/8"	SG15TE	M56 2 1/4"	SG15TE	M84	SG25TE				
34"	M39 1 1/2"	SG13TE	M48 1 7/8"	SG15TE	M48 1 7/8"	SG15TE	M56 2 1/4"	SG15TE	M90 3 1/2"	SG25TE				
36"	M39 1 1/2"	SG13TE	M52 2"	SG15TE	M52 2"	SG15TE	M56 2 1/4"	SG15TE	M90 3 1/2"	SG25TE				
38"	M39 1 1/2"	SG13TE	M39 1 1/2"	SG13TE	M39 1 1/2"	SG13TE	M56 2 1/4"	SG15TE	M90 3 1/2"	SG25TE				
40"	M39 1 1/2"	SG13TE	M42 1 5/8"	SG13TE	M42 1 5/8"	SG13TE	M56 2 1/4"	SG15TE	M90 3 1/2"	SG25TE				
42"	M39 1 1/2"	SG13TE	M42 1 5/8"	SG13TE	M42 1 5/8"	SG13TE	M56 2 1/4"	SG15TE	M90 3 1/2"	SG25TE				
44"	M39 1 1/2"	SG13TE	M45 1 3/4"	SG13TE	M45 1 3/4"	SG13TE	M56 2 1/4"	SG15TE	M95 3 3/4"	SG25TE				
46"	M39 1 1/2"	SG13TE	M48 1 7/8"	SG15TE	M48 1 7/8"	SG15TE	M56 2 1/4"	SG15TE	M100 4"	SG25TE				
48"	M39 1 1/2"	SG13TE	M48 1 7/8"	SG15TE	M48 1 7/8"	SG15TE	M70 2 3/4"	SG18TE	M100 4"	SG25TE				

ASME SERIES A LAPPED

Nominal pipe size	Class 150		Class 300		Class 400		Class 600		Class 900		Class 1500		Class 2500	
	collet	tool	collet	tool	collet	tool	collet	tool	collet	tool	collet	tool	collet	tool
1/2"									M20 3/4"	SG4TM	M20 3/4"	SG4TM	M20 3/4"	SG4TM
3/4"			M16 5/8"	SG4TM	M16 5/8"	SG4TM	M16 5/8"	SG4TM	M20 3/4"	SG4TM	M20 3/4"	SG4TM	M20 3/4"	SG4TM
1"			M16 5/8"	SG4TM	M16 5/8"	SG4TM	M16 5/8"	SG4TM	M24 7/8"	SG6TM	M24 7/8"	SG6TM	M24 7/8"	SG6TM
1 1/4"			M16 5/8"	SG4TM	M16 5/8"	SG4TM	M16 5/8"	SG4TM	M24 7/8"	SG6TM	M24 7/8"	SG6TM	M27 1"	SG6TM
1 1/2"			M20 3/4"	SG4TM	M20 3/4"	SG4TM	M20 3/4"	SG4TM	M27 1"	SG6TM	M27 1"	SG6TM	M30 1 1/8"	SG11TM
2"	M16 5/8"	SG4TM	M16 5/8"	SG4TM	M16 5/8"	SG4TM	M16 5/8"	SG4TM	M24 7/8"	SG6TM	M24 7/8"	SG6TM	M27 1"	SG6TM
2 1/2"	M16 5/8"	SG4TM	M20 3/4"	SG4TM	M20 3/4"	SG4TM	M20 3/4"	SG4TM	M27 1"	SG6TM	M27 1"	SG6TM	M30 1 1/8"	SG11TM
3"	M16 5/8"	SG4TM	M20 3/4"	SG4TM	M20 3/4"	SG4TM	M20 3/4"	SG4TM	M24 7/8"	SG6TM	M30 1 1/8"	SG11TM	M33 1 1/4"	SG11TM
3 1/2"	M16 5/8"	SG4TM	M20 3/4"	SG4TM	M24 7/8"	SG6TM	M24 7/8"	SG6TM	no flange		no flange		no flange	
4"	M16 5/8"	SG4TM	M20 3/4"	SG4TM	M24 7/8"	SG6TM	M24 7/8"	SG6TM	M30 1 1/8"	SG11TM	M33 1 1/4"	SG11TM	M39 1 1/2"	SG13TE
5"	M20 3/4"	SG4TM	M20 3/4"	SG4TM	M24 7/8"	SG6TM	M27 1"	SG6TM	M33 1 1/4"	SG11TM	M39 1 1/2"	SG13TE	M45 1 3/4"	SG13TE
6"	M20 3/4"	SG4TM	M20 3/4"	SG4TM	M24 7/8"	SG6TM	M27 1"	SG6TM	M30 1 1/8"	SG11TM	M36 1 3/8"	SG11TM	M52 2"	SG15TE
8"	M20 3/4"	SG4TM	M24 7/8"	SG6TM	M27 1"	SG6TM	M30 1 1/8"	SG11TM	M36 1 3/8"	SG11TM	M42 1 5/8"	SG13TE	M52 2"	SG15TE
10"	M24 7/8"	SG6TM	M27 1"	SG6TM	M30 1 1/8"	SG11TM	M33 1 1/4"	SG11TM	M36 1 3/8"	SG11TM	M48 1 7/8"	SG15TE	M64 2 1/2"	SG18TE
12"	M24 7/8"	SG6TM	M30 1 1/8"	SG11TM	M33 1 1/4"	SG11TM	M33 1 1/4"	SG11TM	M36 1 3/8"	SG11TM	M52 2"	SG15TE	M70 2 3/4"	SG18TE

ASME SERIES A SOCKET WELDED

Nominal pipe size	Class 150		Class 300		Class 600		Class 1500	
	collet	tool	collet	tool	collet	tool	collet	tool
1/2"							M20 3/4"	SG4TM
3/4"			M16 5/8"	SG4TM	M16 5/8"	SG4TM	M20 3/4"	SG4TM
1"			M16 5/8"	SG4TM	M16 5/8"	SG4TM	M24 7/8"	SG6TM
1 1/4"			M16 5/8"	SG4TM	M16 5/8"	SG4TM	M24 7/8"	SG6TM
1 1/2"			M20 3/4"	SG4TM	M20 3/4"	SG4TM	M27 1"	SG6TM
2"	M16 5/8"	SG4TM	M16 5/8"	SG4TM	M16 5/8"	SG4TM	M24 7/8"	SG6TM
2 1/2"	M16 5/8"	SG4TM	M20 3/4"	SG4TM	M20 3/4"	SG4TM	M27 1"	SG6TM
3"	M16 5/8"	SG4TM	M20 3/4"	SG4TM	M20 3/4"	SG4TM		

ASME SERIES B WELD NECK AND BLIND

Nominal pipe size	Class 150		Class 300		Class 400		Class 600		Class 900	
	collet	tool	collet	tool	collet	tool	collet	tool	collet	tool
26"	M20 3/4"	SG4TM	M33 1 1/4"	SG11TM	M36 1 3/8"	SG11TM	M42 1 5/8"	SG13TE	M64 2 1/2"	SG18TE
28"	M20 3/4"	SG4TM	M33 1 1/4"	SG11TM	M39 1 1/2"	SG13TE	M45 1 3/4"	SG13TE	M70 2 3/4"	SG18TE
30"	M20 3/4"	SG4TM	M36 1 3/8"	SG11TM	M39 1 1/2"	SG13TE	M48 1 7/8"	SG15TE	M76 3"	SG25TE
32"	M20 3/4"	SG4TM	M39 1 1/2"	SG13TE	M42 1 5/8"	SG13TE	M52 2"	SG15TE	M76 3"	SG25TE
34"	M24 7/8"	SG6TM	M39 1 1/2"	SG13TE	M42 1 5/8"	SG13TE	M56 2 1/4"	SG15TE	M80 3 1/4"	SG25TE
36"	M24 7/8"	SG6TM	M42 1 5/8"	SG13TE	M45 1 3/4"	SG13TE	M56 2 1/4"	SG15TE	M76 3"	SG25TE
42"	M27 1"	SG6TM	M45 1 3/4"	SG13TE						
48"	M30 1 1/8"	SG11TM	M48 1 7/8"	SG15TE						
54"	M30 1 1/8"	SG11TM	M48 1 7/8"	SG15TE						
60"	M33 1 1/4"	SG11TM	M56 2 1/4"	SG15TE						

### API 6B WELD NECK

Nominal pipe size	Class					
	138 bar (2000 psi)		207 bar (3000 psi)		345 bar (5000 psi)	
	collet	tool	collet	tool	collet	tool
2 1/16"	M16 5/8"	SG4TM	M24 7/8"	SG6TM	M24 7/8"	SG6TM
2 9/16"	M20 3/4"	SG4TM	M27 1"	SG6TM	M27 1"	SG6TM
3 1/8"	M20 3/4"	SG4TM	M24 7/8"	SG6TM	M30 1 1/8"	SG11TM
4 1/16"	M24 7/8"	SG6TM	M30 1 1/8"	SG11TM	M33 1 1/4"	SG11TM
5 1/8"	M27 1"	SG6TM	M33 1 1/4"	SG11TM	M39 1 1/2"	SG13TE
7 1/16"	M27 1"	SG6TM	M30 1 1/8"	SG11TM	M36 1 3/8"	SG11TM
9"	M30 1 1/8"	SG11TM	M36 1 3/8"	SG11TM	M42 1 5/8"	SG13TE
11"	M33 1 1/4"	SG11TM	M36 1 3/8"	SG11TM	M48 1 7/8"	SG15TE

### API 6B BLIND AND THREADED

Nominal pipe size	Class					
	138 bar (2000 psi)		207 bar (3000 psi)		345 bar (5000 psi)	
	collet	tool	collet	tool	collet	tool
2 1/16"	M16 5/8"	SG4TM	M24 7/8"	SG6TM	M24 7/8"	SG6TM
2 9/16"	M20 3/4"	SG4TM	M27 1"	SG6TM	M27 1"	SG6TM
3 1/8"	M20 3/4"	SG4TM	M24 7/8"	SG6TM	M30 1 1/8"	SG11TM
4 1/16"	M24 7/8"	SG6TM	M30 1 1/8"	SG11TM	M33 1 1/4"	SG11TM
5 1/8"	M27 1"	SG6TM	M33 1 1/4"	SG11TM	M39 1 1/2"	SG13TE
7 1/16"	M27 1"	SG6TM	M30 1 1/8"	SG11TM	M36 1 3/8"	SG11TM
9"	M30 1 1/8"	SG11TM	M36 1 3/8"	SG11TM	M42 1 5/8"	SG13TE
11"	M33 1 1/4"	SG11TM	M36 1 3/8"	SG11TM	M48 1 7/8"	SG15TE
13 5/8"	M33 1 1/4"	SG11TM	M36 1 3/8"	SG11TM		
16 3/4"	M39 1 1/2"	SG13TE	M42 1 5/8"	SG13TE		
21 1/4"	M42 1 5/8"	SG13TE	M52 2"	SG15TE		

### API 6BX WELD NECK

Nominal pipe size	Class					
	690 bar (10000 psi)		1035 bar (15000 psi)		1380 bar (20000 psi)	
	collet	tool	collet	tool	collet	tool
1 13/16"	M20 3/4"	SG4TM	M24 7/8"	SG6TM	M27 1"	SG6TM
2 1/16"	M20 3/4"	SG4TM	M24 7/8"	SG6TM	M30 1 1/8"	SG11TM
2 9/16"	M24 7/8"	SG6TM	M27 1"	SG6TM	M33 1 1/4"	SG11TM
3 1/16"	M27 1"	SG6TM	M30 1 1/8"	SG11TM	M36 1 3/8"	SG11TM
4 1/16"	M30 1 1/8"	SG11TM	M36 1 3/8"	SG11TM	M45 1 3/4"	SG13TE
5 1/8"	M30 1 1/8"	SG11TM				
7 1/16"	M39 1 1/2"	SG13TE	M39 1 1/2"	SG13TE	M52 2"	SG15TE
9"	M39 1 1/2"	SG13TE				
11"	M45 1 3/4"	SG13TE				
13 5/8"	M48 1 7/8"	SG15TE				
16 3/4"	M48 1 7/8"	SG15TE				

### API 6BX BLIND AND TEST

Nominal pipe size	Class					
	690 bar (10000 psi)		1035 bar (15000 psi)		1380 bar (20000 psi)	
	collet	tool	collet	tool	collet	tool
1 13/16"	M20 3/4"	SG4TM	M24 7/8"	SG6TM	M27 1"	SG6TM
2 1/16"	M20 3/4"	SG4TM	M24 7/8"	SG6TM	M30 1 1/8"	SG11TM
2 9/16"	M24 7/8"	SG6TM	M27 1"	SG6TM	M33 1 1/4"	SG11TM
3 1/16"	M27 1"	SG6TM	M33 1 1/4"	SG11TM	M36 1 3/8"	SG11TM
4 1/16"	M30 1 1/8"	SG11TM	M42 1 5/8"	SG13TE	M45 1 3/4"	SG13TE





# 9.

## REGULATORY INFORMATION

### 9.1

#### REGISTERED HEAD OFFICE

EQUALIZER INTERNATIONAL LTD.  
Equalizer House  
Claymore Drive  
Aberdeen  
Scotland  
AB23 8GD

# 10.

## PARTS LISTS & SERVICE KITS

**SG18TE SPREADING PLUG PARTS LIST**

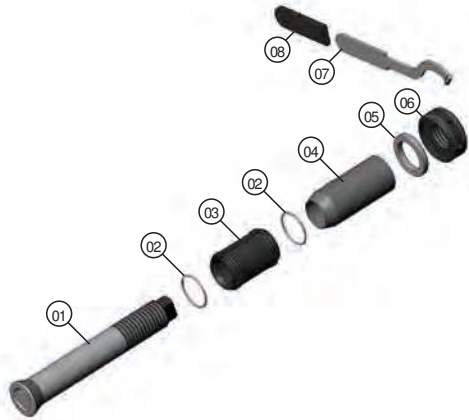

ITEM	PART NO.	DESCRIPTION	QUANTITY
01	666001-01	COLLET PLUG	01
02	663101-02	M60 SPRING RING	02
	633501-02	M64 SPRING RING	02
	633701-02	M70 SPRING RING	02
03	663001-01	M60 COLLET	01
	663401-01	M64 COLLET	01
	633601-01	M70 COLLET	01
04	662201-01	DRIVE CONE	01
05	662101-01	NYLON WASHER	01
06	662001-01	DRIVE NUT	01
07	662601-01	SPANNER	01
08	312301-02	SPANNER SLEEVE	01

**SG18TE ACTUATOR PARTS LIST**

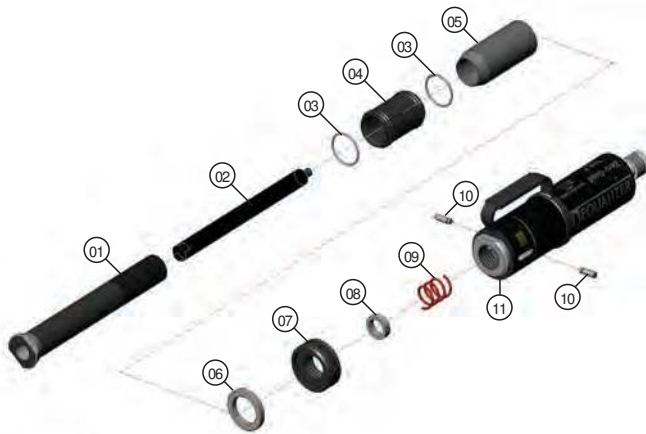

ITEM	PART NO.	DESCRIPTION	QUANTITY
01	662301-01	COLLET HOLDER	01
02	662401-01	PISTON ROD	01
03	663101-02	M60 SPRING RING	02
	633501-02	M64 SPRING RING	02
	633701-02	M70 SPRING RING	02
04	663001-01	M60 COLLET	01
	663401-01	M64 COLLET	01
	633601-01	M70 COLLET	01
05	662201-01	DRIVE CONE	01
06	662101-01	NYLON WASHER	01
07	662001-01	DRIVE NUT	01
08	661401-01	SPRING COLLAR	01
09	661301-01	SAFETY SPRING	01
10	661101-01	DOWEL PIN	02
11		SEE HYDRAULIC CYLINDER PARTS LIST	01

**SG18TE HYDRAULIC CYLINDER PARTS LIST**



ITEM	PART NO.	DESCRIPTION	QUANTITY
01	660801-01	PISTON	01
02	660501-01	PISTON SEAL	01
03	660301-01	PISTON BACKUP RING	01
04	660701-01	PISTON PACKING	01
05	660401-01	CYLINDER BODY	01
06	661601-01	INNER RETURN SPRING	01
07	660901-01	OUTER RETURN SPRING	01
08	661201-01	CYLINDER CAP	01
09	661501-01	CYLINDER HANDLE	01
10	402101-01	M5 CAPHEAD SCREW	02

**SG25TE SPREADING PLUG PARTS LIST**

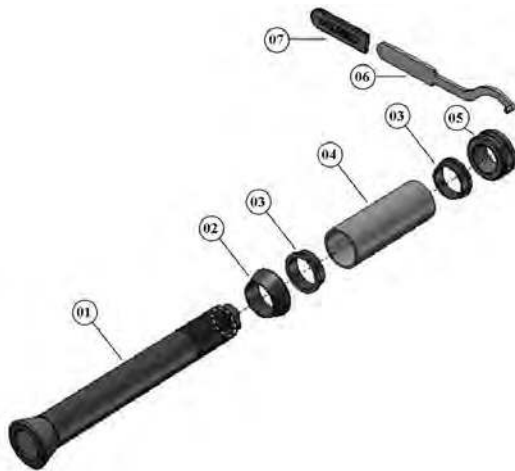

ITEM	PART NO.	DESCRIPTION	QUANTITY
01	676001-01	COLLET PLUG	01
02	672201-02	DRIVE CONE	01
03	672101-04	THRUST WASHER	02
04	675501-02	DRIVE TUBE	01
05	672001-02	DRIVE NUT	01
06	662601-01	SPANNER	01
07	312301-02	SPANNER SLEEVE	01

**SG25TE ACTUATOR PARTS LIST**

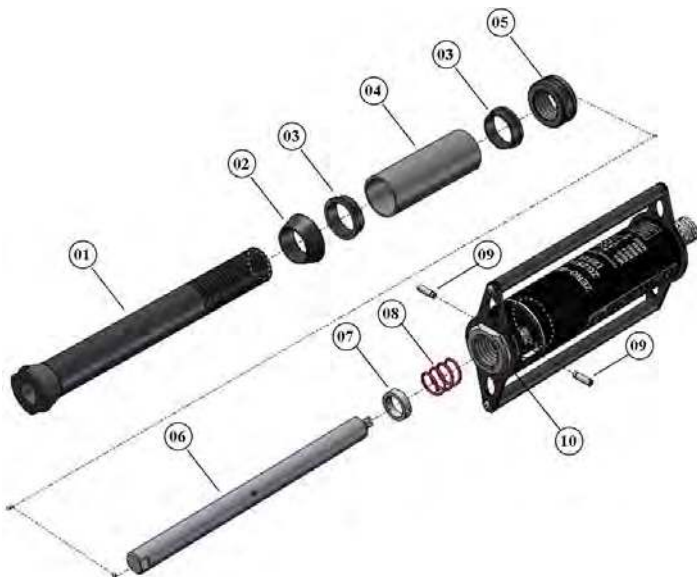

ITEM	PART NO.	DESCRIPTION	QUANTITY
01	672301-01	COLLET HOLDER	01
02	672201-02	DRIVE CONE	01
03	672101-04	THRUST WASHER	02
04	675501-02	DRIVE TUBE	01
05	672001-02	DRIVE NUT	01
06	672401-01	PISTON ROD	01
07	671401-01	SPRING COLLAR	01
08	661301-01	SAFETY SPRING	01
09	661101-02	SPRING COLLAR DOWELL	02
10		SEE HYDRAULIC CYLINDER PART LIST	

**SG25TE HYDRAULIC CYLINDER PARTS LIST**

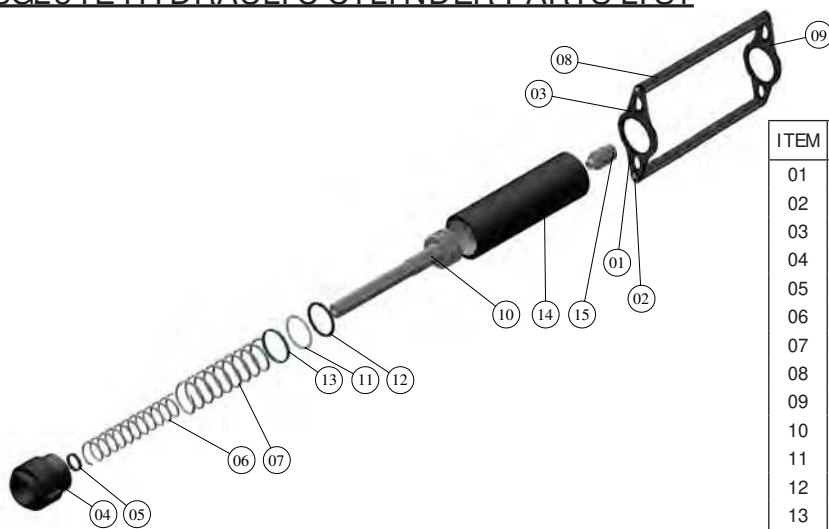

ITEM	PART NO.	DESCRIPTION	QUANTITY
01	402101-01	HANDLE SCREWS	02
02	633001-01	HANDLE RETAINING BOLT	04
03	671501-01	CYLINDER HANDLE FRONT PROFILE	01
04	671201-01	CYLINDER CAP	01
05	671001-01	PISTON ROD BEARING	01
06	671101-01	HYDRAULIC RETURN SPRING 1	01
07	670901-01	HYDRAULIC RETURN SPRING 2	01
08	671701-01	CYLINDER HANDLE	01
09	671601-01	CYLINDER HANDLE REAR PROFILE	01
10	670801-01	HYDRAULIC PISTON	01
11	670601-01	PISTON SEAL BACKUP RING	01
12	670501-01	PISTON SEAL	01
13	670701-01	PISTON BEARING	01
14	670401-01	HYDRAULIC CYLINDER	01
15	300901-01	COUPLER	01





EQUALIZER INTERNATIONAL LTD.

Head Office  
Equalizer House  
Claymore Drive  
Aberdeen  
Scotland  
UK

AB23 8GD

t: +44 (0) 1224 701970

f: +44 (0) 1224 823791

[www.equalizerinternational.com](http://www.equalizerinternational.com)