

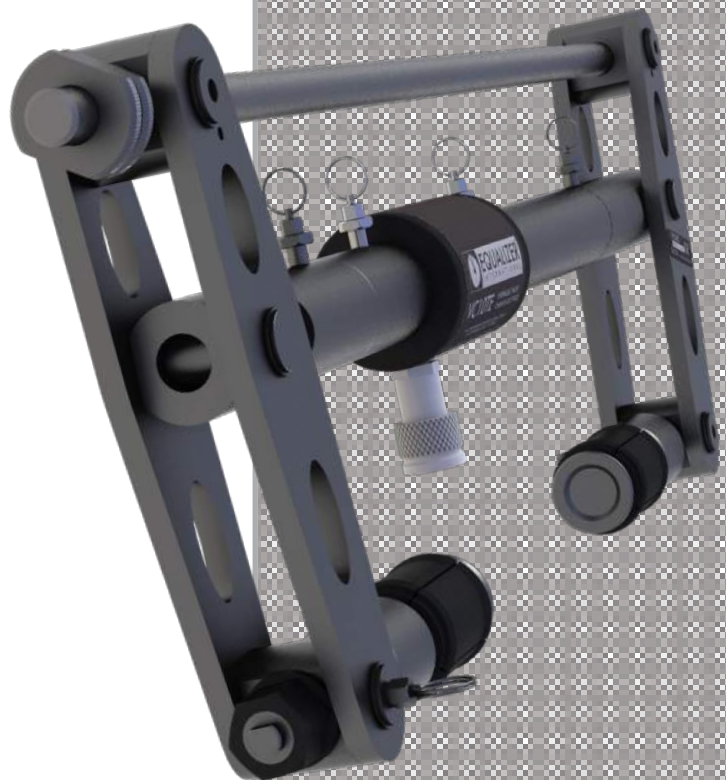

# VC10/13TE VC10/15TE VC10/18TE VC10/25TE

*Torque and tension specialist*

HYDRAULIC  
SECURE-GRIP  
VALVE  
CHANGE-OUT  
TOOLS



# CONTENTS

1. INTRODUCTION
2. TOOL SAFETY
  - 2.1 GENERAL SAFETY
  - 2.2 PERSONNEL COMPETENCY
  - 2.3 DISCLAIMER
  - 2.4 DEFINITION OF TERMS
  - 2.5 HAZARDS
3. TOOL OPERATION
  - 3.1 GENERAL GUIDANCE
  - 3.2 COLLET SELECTION
  - 3.3 BOLT-HOLE MEASUREMENT
  - 3.4 TOOL ASSEMBLY
  - 3.5 COLLET REPLACEMENT
  - 3.6 COLLET LEG SUBASSEMBLY INSTALLATION
  - 3.7 ACTUATOR & EXTENSION ASSEMBLY INSTALLATION
  - 3.8 TENSION BAR SUBASSEMBLY INSTALLATION
  - 3.9 MULTIPLE TOOLS
  - 3.10 HYDRAULIC PUMP INSTALLATION
  - 3.11 TOOL CHECKS
  - 3.12 SPREADING THE FLANGE JOINT
  - 3.13 VALVE OR SPACER REMOVAL
  - 3.14 FLANGE JOINT CLOSURE
  - 3.15 SUB-SEA USAGE
  - 3.16 OPERATING CONDITIONS
4. TOOL MAINTENANCE
  - 4.1 INSPECTION
  - 4.2 DISASSEMBLY
  - 4.3 SERVICING
  - 4.4 RE-ASSEMBLY
  - 4.5 STORAGE & TRANSPORTATION
5. TECHNICAL SPECIFICATIONS
  - 5.1 VC10 SPACIAL ENVELOPE
  - 5.2 VC10 TOOL CAPABILITIES
  - 5.3 OVERALL VC10 TOOL DIMENSIONS
  - 5.4 VC10 TOOL CONFIGURATIONS
  - 5.5 KIT CONTENTS
6. TROUBLESHOOTING
  - 6.1 VC10/13TE, VC10/15TE, VC10/18TE, VC10/25TE TROUBLESHOOTING
7. REGULATORY INFORMATION
  - 7.1 REGISTERED HEAD OFFICE
  - 7.2 APPLICABLE PATENT NUMBERS
8. PARTS LISTS & SERVICE KITS

19/08/2019

# 1.

## INTRODUCTION

The Equalizer™ VC Range of Valve Change-Out tools has been developed to assist in the removal of wafer/butterfly valves, spades/spacers or gaskets from large flange joints. The span of the tool is longer than a standard Secure-Grip Flange Spreader and is adjustable to enable the tool to operate in a range of situations.



The tool has been designed to cope with the loads and dimensions associated with these flange joints while remaining relatively lightweight and user-friendly.

It is essential that the user familiarises themselves with the contents of this manual prior to using the tool.

This manual contains information for the following tools:

- VC10/13TE Hydraulic Valve-Change-Out Tool
- VC10/15TE Hydraulic Valve-Change-Out Tool
- VC10/18TE Hydraulic Valve-Change-Out Tool
- VC10/25TE Hydraulic Valve-Change-Out Tool

# 2.

## TOOL SAFETY

### 2.1

#### GENERAL SAFETY

These instructions cover the safe operation and maintenance of THE EQUALIZER **VC10/13TE, VC10/15TE, VC10/18TE** and **VC10/25TE** VALVE CHANGE-OUT tools. The use of any tools should be as part of a broader task-based risk assessment, which should be carried out by the operation supervisor or other competent person.

Failure to comply with the safety information contained within this manual could result in personal injury or equipment damage. Read all instructions, warnings and cautions carefully, and follow all safety precautions.

The safety of the operator, any assisting personnel and the general public is of paramount importance. Always work in accordance with applicable national, local, site & company-wide safety procedures.

### 2.2

#### PERSONNEL COMPETENCY

Only personnel deemed competent in the use of mechanical and hydraulic equipment should use these tools.

### 2.3

#### DISCLAIMER

Equalizer cannot be held responsible for injury or damage resulting from unsafe product use, lack of maintenance or incorrect product and/or system operation. If in doubt as to the safety precautions and applications, contact Equalizer using the contact details at the back of this manual.

## 2.4

### DEFINITION OF TERMS

A **CAUTION** is used to indicate correct operating or maintenance procedures and practices to prevent damage to, or destruction of equipment or other property.

A **WARNING** indicates a potential danger that requires correct procedures or practices to avoid personal injury.

A **DANGER** is only used when your action or lack of action may cause serious injury or even death.



**DO:** an illustration showing how the tool should be used.



**DON'T:** an illustration showing an incorrect way to use a tool.

## 2.5

### HAZARDS



**WARNING:** ensure all hydraulic components are rated to a safe working pressure of 700 bar (10 000 psi).



**WARNING:** Do not overload equipment. The risk of hydraulic overloading can be minimised by using the Equalizer Hand Pump, which has a factory-set safety valve preventing the safe working pressure being exceeded.

If alternative hydraulic pumps are used, ensure that there are adequate systems to limit the working pressure to 700 bar (10 000 psi).



**CAUTION:** ensure components are protected from external sources of damage, such as excessive heat, flame, moving machine parts, sharp edges and corrosive chemicals.



**CAUTION:** Take care to avoid sharp bends and kinks in hydraulic hoses. Bends and kinks can cause severe back-up pressure and cause hose failure. Protect hoses from dropped objects; a sharp impact may cause internal damage to hose wire strands.

Protect hoses from crush risks, such as heavy objects or vehicles; crush damage can cause hose failure.



**WARNING:** Applying pressure to a damaged hose may cause it to rupture.



**WARNING:** Immediately replace worn or damaged parts. Use only genuine Equalizer parts from approved distributors or service centres. Equalizer parts have been engineered and manufactured to be fit-for-purpose.



**DANGER:** To minimise risk of personal injury keep hands and feet away from the tool and workpiece during operation.



**WARNING:** Always wear suitable clothing and Personal Protective Equipment (PPE). Do not handle pressurised hoses; escaping oil under pressure can penetrate the skin, causing serious injury. Seek medical attention immediately if oil penetration is suspected.



**WARNING:** Only pressurize complete and fully connected hydraulic systems. Do not pressurize systems that contain unconnected couplers.



**CAUTION:** Do not lift hydraulic equipment by the hoses or couplers. Use only the designated carrying handles.



**CAUTION:** Lubricate tools as directed in this manual prior to operation. Use only approved lubricants of high quality, following the lubricant manufacturers instructions.



The vibration total value to which this tool is subjected does not exceed 2.5 m/s<sup>2</sup>.

# 3.

## TOOL OPERATION

### 3.1

#### GENERAL GUIDANCE

The VC10 Valve Change-Out Tools are based on the Equalizer Secure-Grip technology, and use collets from the SG tools. The collets are suited to the sizes of the bolt-holes and should be selected prior to commencing work by following the instructions in this section.

Replacement collets or different collets to suit different bolt-hole sizes are available from a local Equalizer distributor.

### 3.2

#### COLLET SELECTION



**WARNING:** It is important that the correct size of collet is used. An undersized collet could allow the collet holder to pull through its bore. An oversized collet has the potential to become jammed in the bolt-hole.

The VC Range of Valve Change-Out tools have a range of collets which are applicable to the following bolts and flange bolt-hole diameters shown in the table below.

If the specification of the flange is unknown then the vernier caliper supplied in the kit should be used to determine the correct collet.

Minimum bolt-hole diameter (mm)	Maximum bolt-hole diameter (mm)	COLLET	TOOL
38	42	<b>M39</b>	<b>VC10/13TE</b>
41	45	<b>M42</b>	
44	49	<b>M45</b>	
47.5	52	<b>M48</b>	<b>VC10/15TE</b>
50.5	56	<b>M52</b>	
55.5	62	<b>M56</b>	
59.5	63	<b>M60</b>	<b>VC10/18TE</b>
63	69	<b>M64</b>	
69	75	<b>M70</b>	
75	81	<b>M76</b>	<b>VC10/25TE</b>
79	86	<b>M80</b>	
83	88	<b>M84</b>	
88	94	<b>M90</b>	
94	101	<b>M95</b>	
99	107	<b>M100</b>	

### 3.3 BOLT-HOLE MEASUREMENT

To ensure a true measurement is taken, hold the vernier caliper:

- square to the flange face
- in the middle of the bolt-hole

It is important that the vernier caliper is held in the middle of the bolt-hole, and not held at an angle to the flange face, nor used on a bolt-hole which is worn, damaged or distorted, as these actions may result in the selection of an incorrect size of collet.

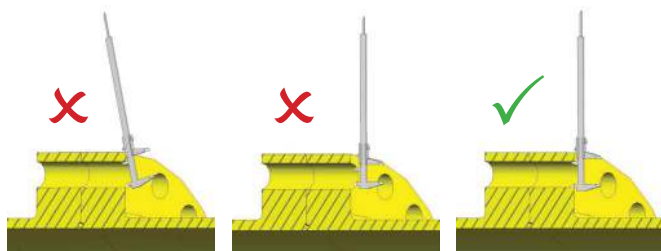

To confirm that the bolt-hole is round, take two separate measurements with the vernier calliper turned through 90° between measurements.

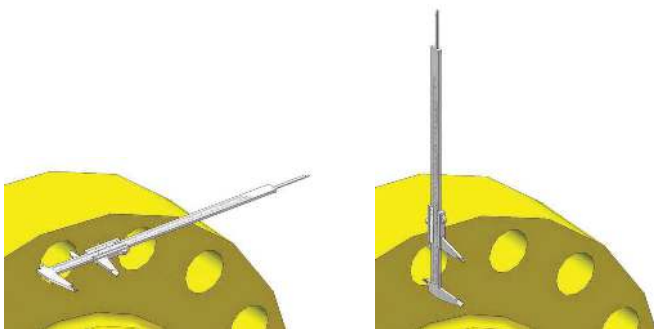

To read the measurement from the vernier caliper, scan along the desired scale from left to right. In this example, the major figure is 60 mm, this is added to the minor figure of 8 mm (indicated by where the vernier scale aligns with the main scale), giving a total measurement of 68 mm.

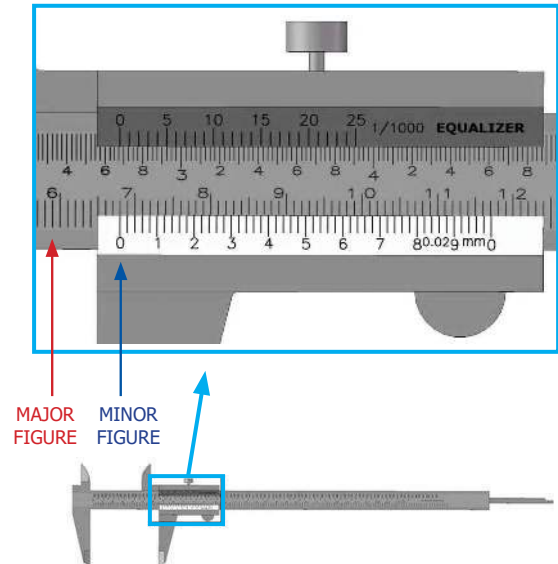

With a bolt-hole size of 68 mm, the operator can determine which collet and tool is appropriate to this flange by referring to the table. For example: 68 mm falls within the 63 mm minimum and 69 mm maximum bolt-hole sizes.

Therefore collet identification is M64 / 2½"

If the measurement contains fractions of a millimetre the method of reading the vernier caliper is slightly different. In this example, the major figure is 40 mm (read in the same way as previously described). The minor figure is 7 mm (read to the left of the zero). The fraction is 0.5 mm (read from where the vernier scale lines up with the main scale). This gives a total measurement of 47.5 mm.

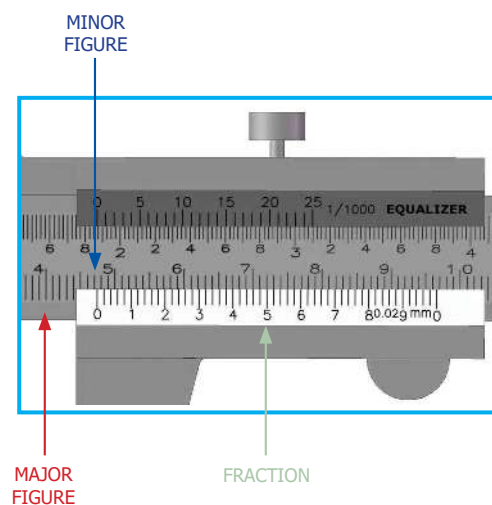

### 3.4 TOOL ASSEMBLY

The size and weight of a VC10 Tool mean that it should always be handled as 4 separate sub-assemblies. Do not attempt to carry or move the tool when fully assembled.

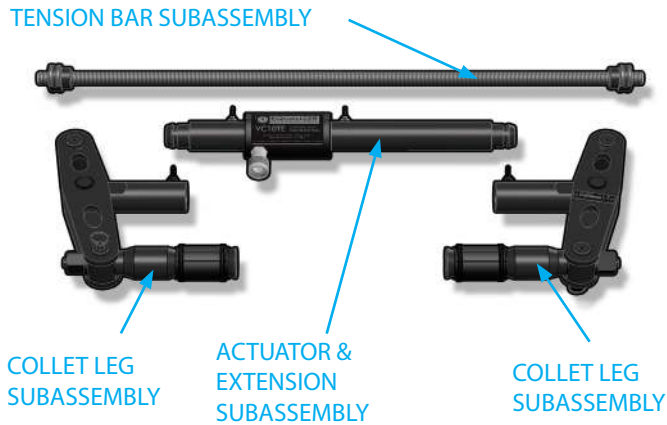

**WARNING:** Before attaching the tool ensure at least two flange bolts remain in place 180 degrees apart with nuts loosened sufficiently enough for flange work to be carried out. These bolts will reduce lateral flange movement during flange spreading.

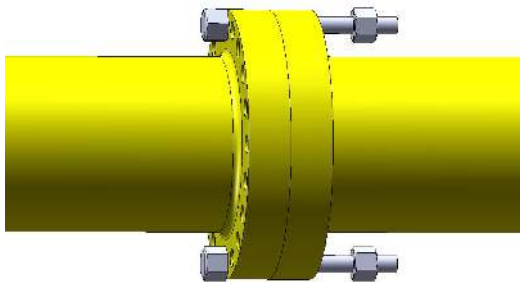

### 3.5 COLLET REPLACEMENT

Once the correct Collet has been selected it should be fitted to the tool prior to use.

Select either of the Collet Leg Subassemblies from the tool. Place the sub-assembly on a safe level surface and unscrew the Collet Nut.



Pull the Collet Spring Plunger Ring to release and remove the Collet Head assembly.

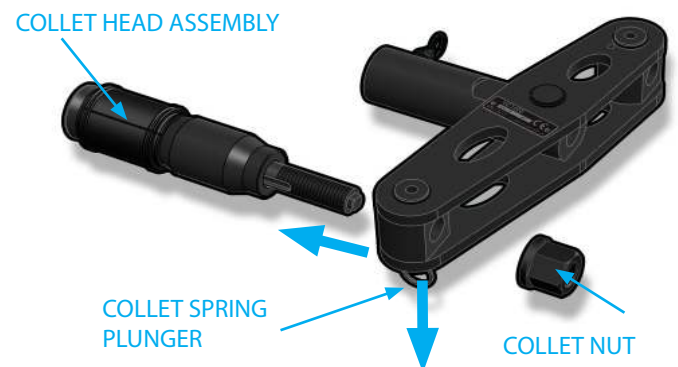

Remove the Drive Cone and Collet from the Collet Holder. Replace the Collet with the applicable size for the flange joint as selected in Section 3.2.

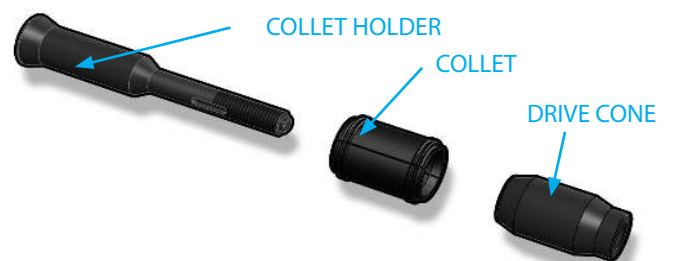

Repeat the operation for the opposite Collet Leg Subassembly.

Reverse the procedure to re-assemble the tool.

## 3.6 COLLET LEG SUBASSEMBLY INSTALLATION

The Collet Leg Subassemblies should be the first parts of the tool fitted to the flange joint.

The Collets from each assembly should be installed into the bolt-hole of the flanges on either side of the joint to be spread. Care should be taken to ensure that the collets are engaged in the correct position.

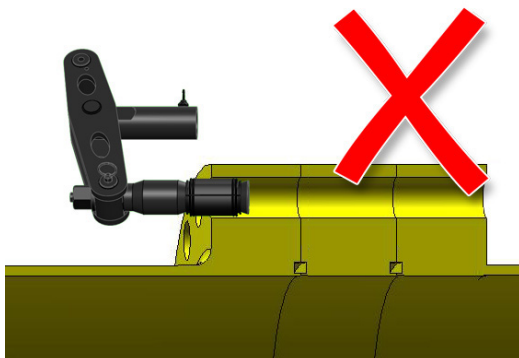
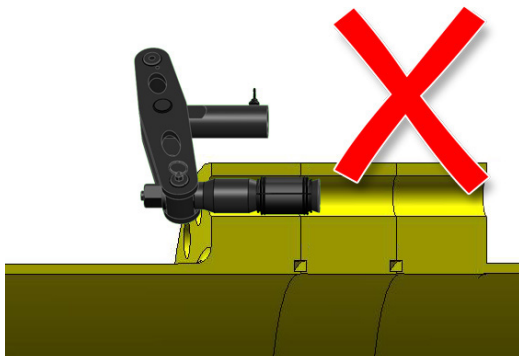
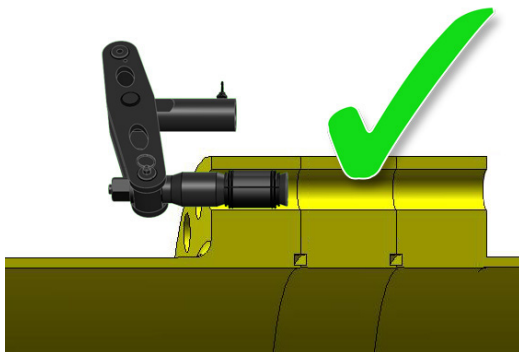

If a spacer, blind or valve is installed between the flanges, care should be taken to ensure that the Collet or Collet Holder do not extend beyond the flange bolt hole.

Tighten the Collet Nut with the 1/2" square drive flexible handle and socket. The first half of the tool will now have a secure hold in the bolt-hole.

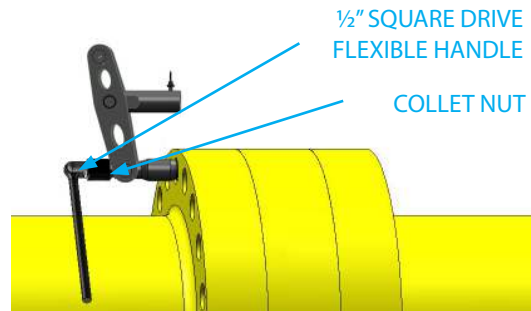

Repeat the process for installing the other Collet Leg Subassembly. If there is no blind, spacer or valve between the flanges then the collet should be inserted until it touches the other Collet Leg Subassembly.

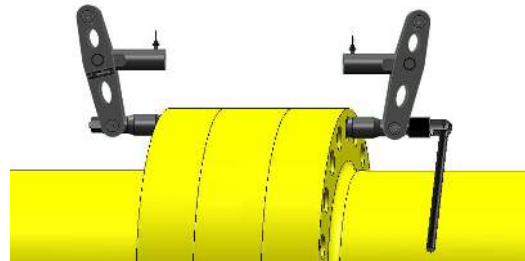

If a blind, spacer or valve is present, measure the remaining exposed size of the previously installed Collet Leg Subassembly and insert the second Collet Leg Subassembly to the same depth on the opposite side.



### 3.7 ACTUATOR AND EXTENSION SUBASSEMBLY INSTALLATION

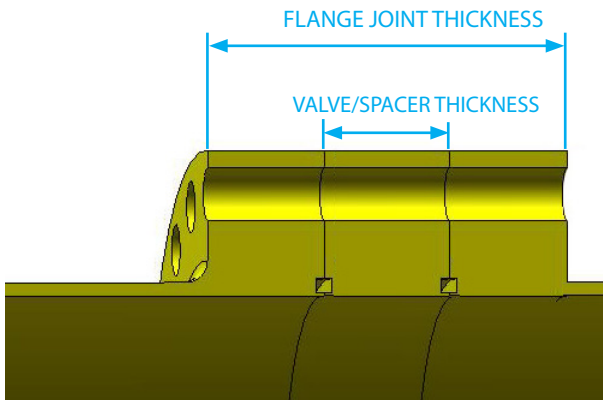

The Actuator and Extension Subassembly can be assembled into 4 different configurations; select the configuration from the table below.

To assemble a given configuration, push the Actuator into the applicable Extension(s) until you feel the Actuator spring plunger click. To remove an Extension, pull the spring plunger and pull the Extension and the Actuator apart.

Do not connect 2 Extensions to each other. The Actuator should always be positioned between the Extensions, or with a single Extension to one side.

#### ACTUATOR AND EXTENSION CONFIGURATIONS

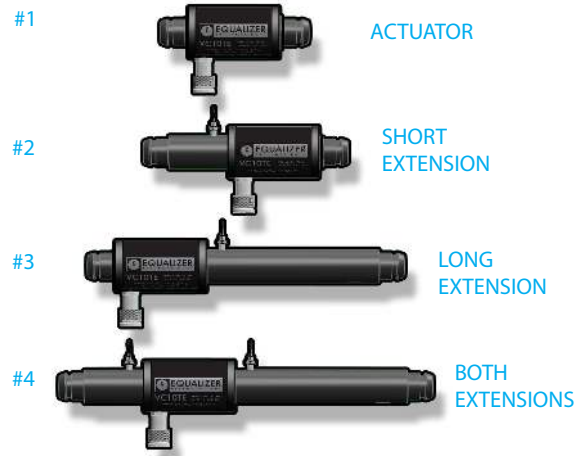

Refer to Section 5 for Tool Dimensions.

#	Configuration	Tool	Minimum Flange Joint Thickness	Maximum Flange Joint Thickness	Minimum Valve/Spacer Thickness	Maximum Valve/Spacer Thickness
1	Actuator only (no Extension)	VC10/13TE	110 mm	320 mm	0 mm	128 mm
		VC10/15TE	130 mm	320 mm	0 mm	44 mm
		VC10/18TE	176 mm	320 mm	0 mm	61 mm
		VC10/25TE	200 mm	320 mm	0 mm	61 mm
2	Actuator + Short Extension	VC10/13TE	238 mm	425 mm	128 mm	290 mm
		VC10/15TE	174 mm	425 mm	44 mm	215 mm
		VC10/18TE	237 mm	425 mm	61 mm	231 mm
		VC10/25TE	261 mm	425 mm	61 mm	231 mm
3	Actuator + Long Extension	VC10/13TE	400 mm	590 mm	290 mm	415 mm
		VC10/15TE	345 mm	590 mm	215 mm	322 mm
		VC10/18TE	407 mm	590 mm	231 mm	355 mm
		VC10/25TE	431 mm	590 mm	231 mm	355 mm
4	Actuator + Both Extensions	VC10/13TE	525 mm	690 mm	415 mm	495 mm
		VC10/15TE	452 mm	690 mm	322 mm	410 mm
		VC10/18TE	527 mm	690 mm	351 mm	444 mm
		VC10/25TE	551 mm	690 mm	351 mm	444 mm

**Table 3.1:** Actuator and Extension Subassembly configurations

Once the required configuration has been assembled, the Actuator and Extension Subassembly can be fitted to the Collet Leg Subassemblies already on the flange joint.

### 3.8 TENSION BAR SUBASSEMBLY INSTALLATION

The Tension Bar Subassembly comprises a long threaded Stud Bar and a pair of Thumb Nuts.

Remove one Thumb Nut (by turning anti-clockwise) and slide the Tension Bar through the hole in the top of one Collet Leg Assembly...

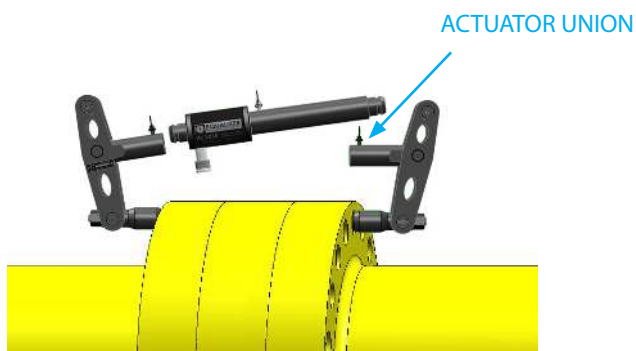

Insert one side of the actuator into each 'actuator union'. On both sides push the actuator until you feel the actuator spring plunger click.

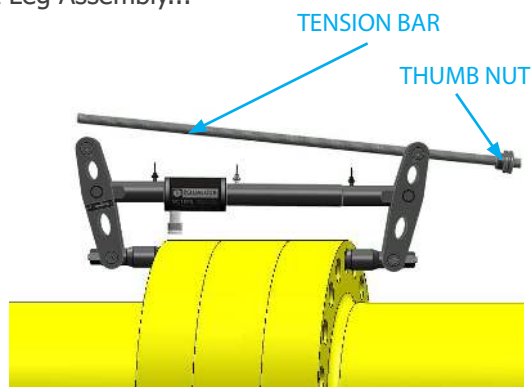
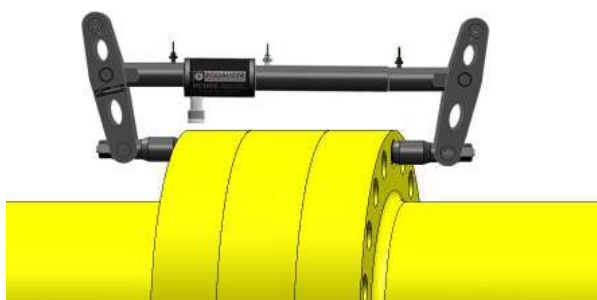

...and then through the hole in the other Collet Leg Subassembly.

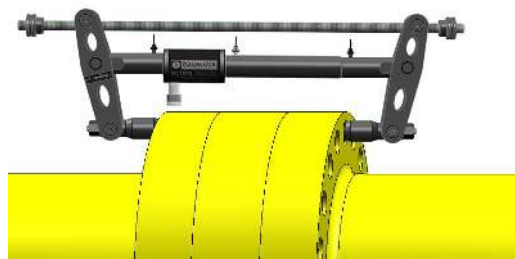

Screw the second Thumb Nut onto the open end and continue to tighten both nuts until hand-tight. Ensure there are a minimum of 3 threads exposed beyond the Thumb Nut.

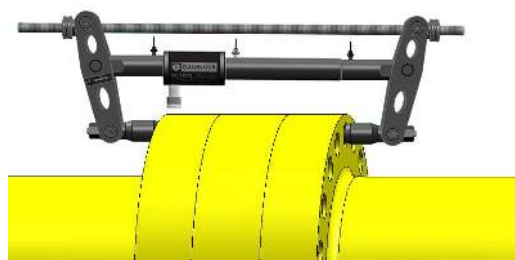

### 3.9 MULTIPLE TOOLS

Flange spreading tools should always be used in multiples to ensure an even parallel flange spread and to avoid misalignment. Where four tools are used, the tools should be paired together (using a Twin-Port Pump) and grouped diametrically opposite to one another. This will leave space for the spacer, blind or valve to be extracted.

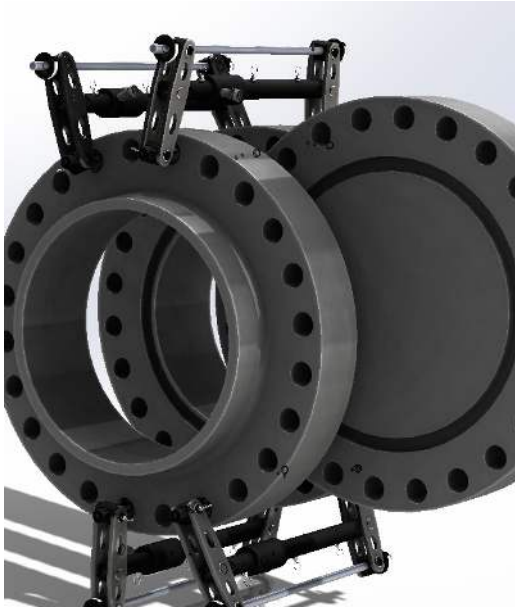

### 3.10 HYDRAULIC PUMP INSTALLATION

Connect the hand pumps to the hydraulic hoses, and the hydraulic hoses to the actuators on each tool. Ensure that all couplers are fully hand tightened and the release valves are closed hand tight.

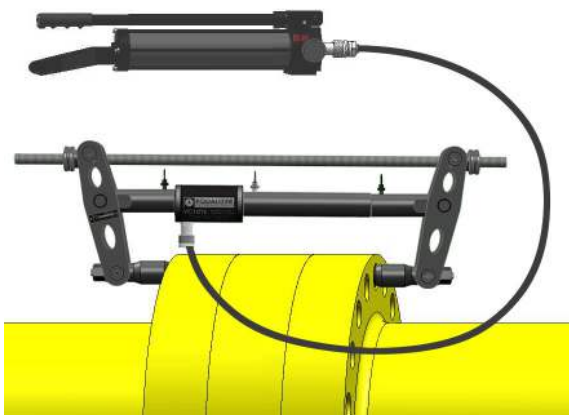

The HP1000D pump can be used to operate two tools simultaneously.

For detailed instructions on the use of the Equalizer HP1000D twin-port Hand Pump consult the Instruction Manual.

### 3.11 TOOL CHECKS



**WARNING:** Ensure that each tool is installed correctly prior to actuating the pump. Actuating the tool when it is not correctly installed could cause injury or equipment damage.



**WARNING:** Do not allow fingers, hands or other body parts to come into contact with the flange or tools during operations. Never place fingers, hands or other body parts into the flange gap.

### 3.12 SPREADING THE FLANGE JOINT

Following the instructions for the HP1000D Twin-Port Hydraulic Hand Pump, actuate the tools, slowly spreading the flange joint.



**WARNING:** Do not allow fingers, hands or other body parts to come into contact with the flange or tools during operations. Never place fingers, hands or other body parts into the flange gap.

### 3.13 VALVE OR SPACER REMOVAL

After the flange joint has been spread, the seal element, blind, spacer or valve can be removed or replaced as required.

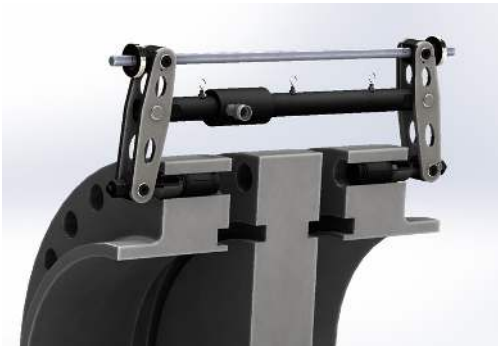

**WARNING:** Do not allow fingers, hands or other body parts to come into contact with the flange or tools during operations. Never place fingers, hands or other body parts into the flange gap.

### 3.14 FLANGE JOINT CLOSURE

After the flange maintenance operation is complete the flanges can be closed in a controlled manner using the tools.



**WARNING:** Do not allow fingers, hands or other body parts to come into contact with the flange or tools during operations. Never place fingers, hands or other body parts into the flange gap.

Ensure the flange gap is clear and that hoses, tools, clothing and any other possible trap hazard are clear of the flange gap.

Gradually release the pressure using the Release Knob (in accordance with the Hand Pump Instruction Manual). Ensure all tools are released slowly and evenly to avoid misalignment or overloading.

### 3.15 SUB-SEA USAGE

The VC Range of Valve Change-Out Tools are actuated by means of single-acting spring-return hydraulic cylinder and can be used sub-sea providing the following actions are taken:

- The pump release valve is fully opened and remains open until the tool has descended to the working depth. This will allow the pressure to equalise.
- The tool is actuated via the hand pump by a diver.
- Upon completion of works the release valve is left in the fully-open position until the tool has ascended to the surface.
- The tool and pump are stripped-down, cleaned and lubricated immediately to minimise corrosion.

### 3.16 OPERATING CONDITIONS

#### HYDRAULIC TOOLS:

Minimum Flange Contact Temperature: -30 °C (-22 °F)

Maximum Flange Contact Temperature: 70 °C (158 °F)

# 4.

## TOOL MAINTENANCE

### 4.1 INSPECTION

On return from each job and before allocation against subsequent work the completeness of the Equalizer Valve Change-Out tool kits must be established and items examined to ensure that they are serviceable.

At regular intervals and specifically after exposure to salt water Valve Change-Out tools should be dismantled and lubricated as follows:

### 4.2 DISASSEMBLY

Lay the tool on a bench or flat surface.



Remove the Thumb Nuts (by turning anti-clockwise), the Tension Bar and the Spiral Retaining Rings. Care should be taken not to over stretch the Retaining Rings during removal or replacement.

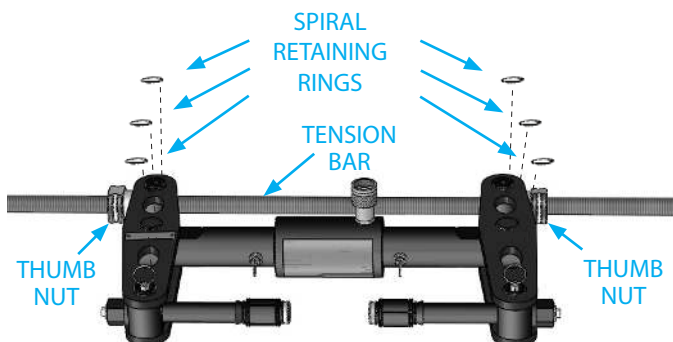

Lift the top leg on both sides from the tool.

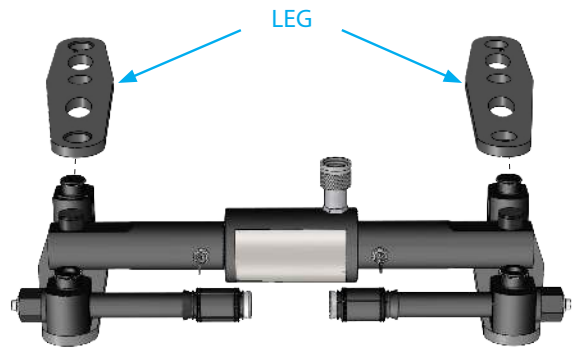

Lift the actuator assembly from the tool.

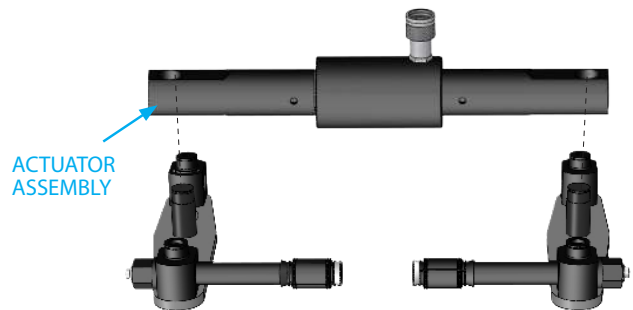

### 4.3 SERVICING

The exposed parts of the tool can now be cleaned and lubricated.

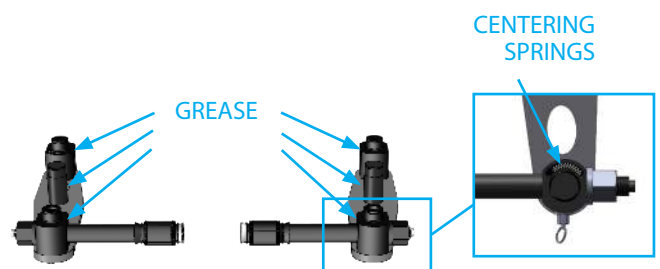

It is recommended that the tool is wiped down with a clean rag and WD40 or similar cleaning fluid to remove any dirt or grit and then liberally greased with a high load bearing grease (Rocol sapphire high load 2 or similar) in the areas shown.

## 4.4

### **RE-ASSEMBLY**

The tool can now be reassembled by reversing the dismantling procedure.

Once the tool is rebuilt, flip the tool over and repeat the above procedure with the other side of the tool. If the actuator requires maintenance please refer to an authorised Equalizer distributor.

## 4.5

### **STORAGE & TRANSPORTATION**

Equalizer tools should be stored in a cool dry place. Tools should always be cleaned, serviced and lubricated prior to storage. Ensure that tools are stored in their designated packing cases.

# 5.

## TECHNICAL SPECIFICATIONS

### 5.1

#### VC10 SPATIAL ENVELOPE

	DIMENSION	MEASURED FROM	MEASURED TO	MINIMUM	MAXIMUM
F	Flange Joint Thickness	Outside Face of Flange	Outside Face of Flange	110 mm - 200 mm	690 mm
V	Valve/Spacer Thickness	Inside Face of Flange	Inside Face of Flange	*0 mm	*495 mm - *444 mm
C	Flange Clearance	Bolt-Hole Circle	Largest OD of Valve/Spacer	-	130 mm
R	Radial space	Bolt-Hole Circle	Closest Obstruction	360 mm	-
A <sub>1</sub>	Axial space (for installation)	Outside Face of Flange	Closest Obstruction	300 mm	-
A <sub>2</sub>	Axial space (installed)	Inner Face of Flange	Closest Obstruction	370 mm	-

**Table 5.1:** Spatial Envelope for VC10-Range of tools. For details on individual tools please refer to Table 3.1

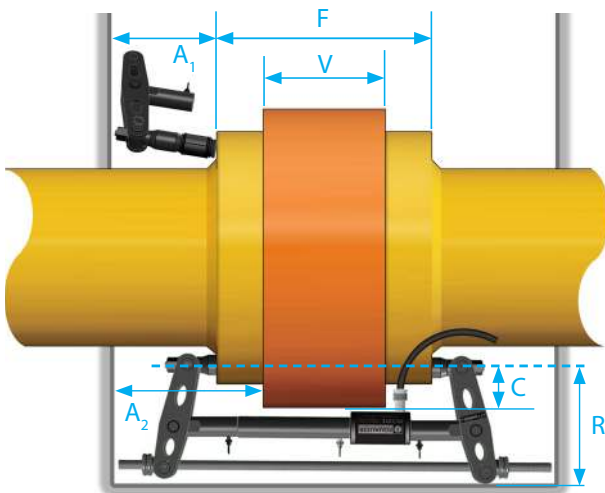

\*Short Collet Holder Kits (SCH) are available which can offer improved range of application.

Contact Equalizer International if your application does not appear to suit standard tools.

### 5.2

#### VC10 TOOL CAPABILITIES

##### SPREADING FORCE

With the maximum 700 bar (10 000 psi) pump pressure applied, each VC10 tool can apply 100 kN (10 T) of spreading force.

When used in pairs, the tools can apply 200 kN (20 T) of spreading force.

When used in a set of 4 tools, the tools can apply 400 kN (40 T) of spreading force.

**SPREADING DISTANCE:** 0 mm - 151 mm

### 5.3

#### OVERALL VC10 TOOL DIMENSIONS

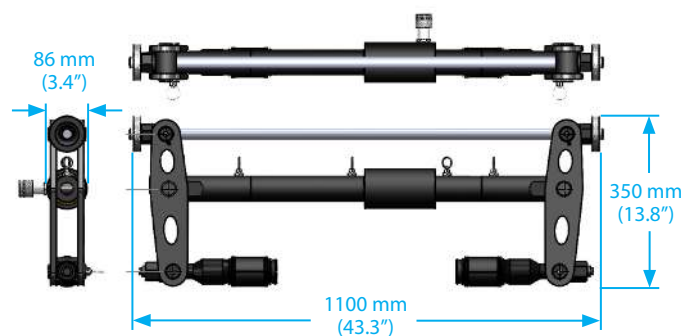

## 5.4

### VC10 TOOL CONFIGURATIONS

#### CONFIGURATION #1

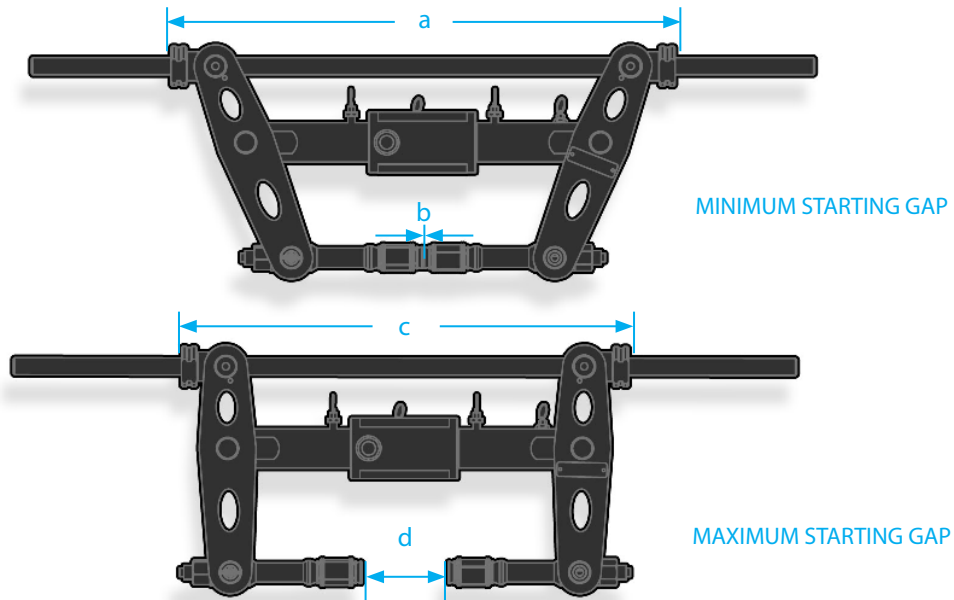

#### CONFIGURATION #2

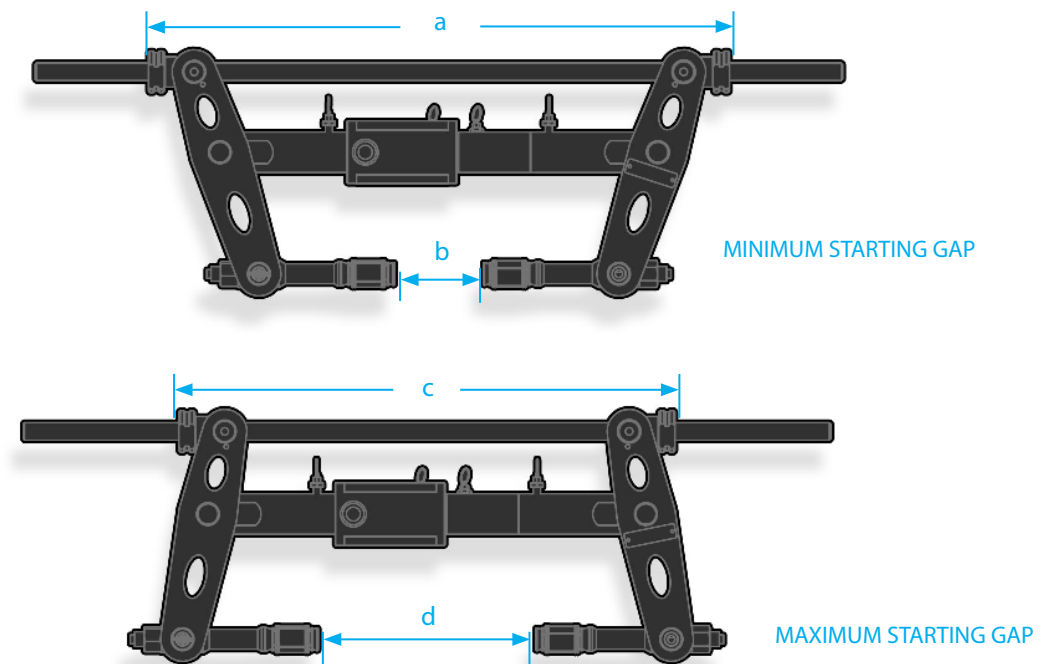



**CONFIGURATION #3**

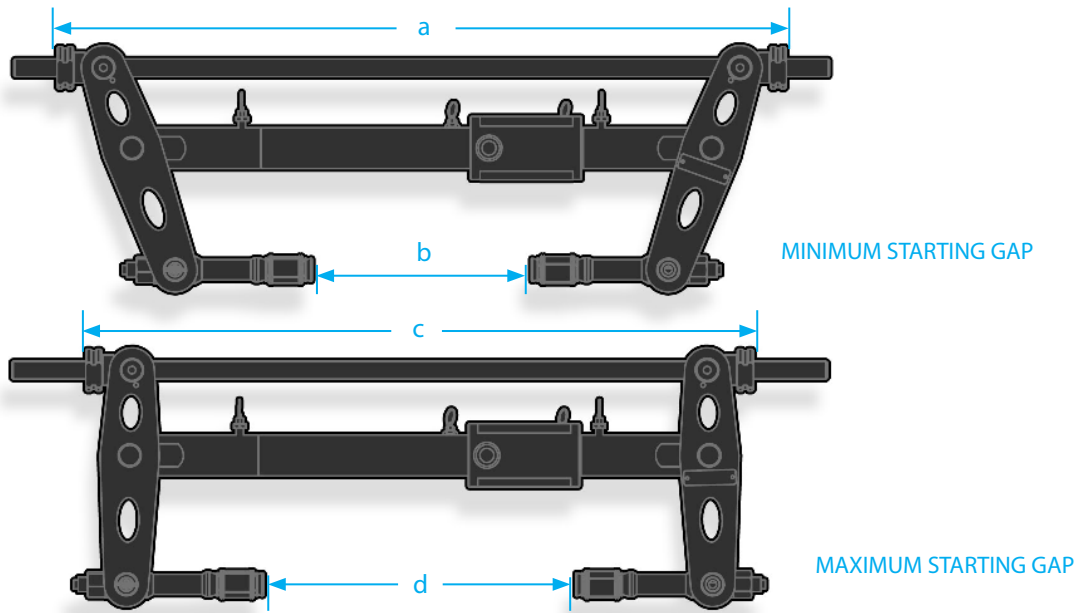

**CONFIGURATION #4**

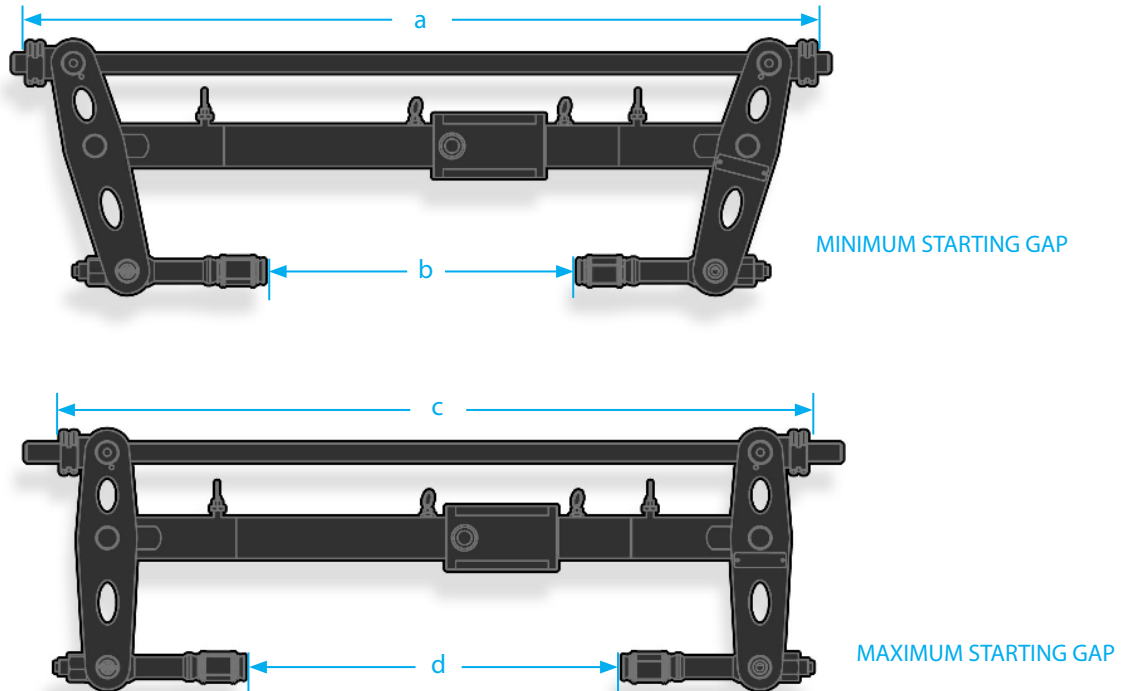

		CONFIGURATION #1 (mm)	CONFIGURATION #2 (mm)	CONFIGURATION #3 (mm)	CONFIGURATION #4 (mm)
a	VC10/13TE	700	778	980	1063
	VC10/15TE	642	780	977	1064
	VC10/18TE	660	782	975	1064
	VC10/25TE	660	782	975	1064
b	VC10/13TE	0	128	290	415
	VC10/15TE	0	44	215	322
	VC10/18TE	0	61	231	351
	VC10/25TE	0	61	231	351
c	VC10/13TE	615	665	895	1006
	VC10/15TE	615	665	895	1006
	VC10/18TE	615	665	895	1006
	VC10/25TE	615	665	895	1006
d	VC10/13TE	128	290	415	495
	VC10/15TE	44	215	322	410
	VC10/18TE	61	231	355	444
	VC10/25TE	61	231	355	444

**Table 5.2:** Dimensions for VC10 Tool Configurations

## 5.5 KIT CONTENTS

### VC10/13TE STANDARD KIT

#### TOOL KIT

- 1 x VC10/13TE Tool
- 2 x M39 Collets
- 2 x M42 Collets
- 2 x M45 Collets
- 1 x Instruction Manual
- 1 x Carry-Case with foam inserts

Carry-Case Dimensions:  
550 mm x 1200 mm x 170 mm (21.7" x 47.2" x 6.7")  
Tool Kit Weight: 50.0 kg (110.2 lb)

#### PUMP KIT

- 1 x HP550S Hydraulic Hand Pump
- 1 x Hydraulic Gauge with manifold
- 1 x 2.0 m (78.74") Hydraulic Hose
- 1 x Secure Grip Safety Block
- 1 x 1/2" Square Drive Flexible Handle with 30 mm Socket
- 1 x Vernier Caliper
- 1 x Instruction Manual
- 1 x Carry-Case with foam inserts

Carry-Case Dimensions:  
550 mm x 1200 mm x 170 mm (21.7" x 47.2" x 6.7")  
Pump-Kit Weight: 27.0 kg (59.5 lb)



Gross Kit Weight: 77.0 kg (169.8 lb)  
(Tool-Kit and Pump-Kit)

### VC10/13TE MAXI KIT

#### TOOL KIT (2 PER MAXI KIT)

- 1 x VC10/13TE Tool
  - 2 x M39 Collets
  - 2 x M42 Collets
  - 2 x M45 Collets
  - 1 x Instruction Manual
  - 1 x Carry-Case with foam inserts
- Carry-Case Dimensions:  
550 mm x 1200 mm x 170 mm (21.7" x 47.2" x 6.7")  
Tool Kit Weight: 50.0 kg (110.2 lb)

#### PUMP KIT

- 1 x HP1000D Hydraulic Hand Pump
  - 2 x Hydraulic Gauge with manifold
  - 2 x 2.0 m (78.74") Hydraulic Hose
  - 2 x Secure Grip Safety Block
  - 1 x 1/2" Square Drive Flexible Handle with 30 mm Socket
  - 1 x Vernier Caliper
  - 1 x Instruction Manual
  - 1 x Carry-Case with foam inserts
- Carry-Case Dimensions:  
550 mm x 1200 mm x 170 mm (21.7" x 47.2" x 6.7")  
Pump-Kit Weight: 30.0 kg (66.1 lb)



Gross Kit Weight: 130.0 kg (286.6 lb)  
(Tool-Kits and Pump-Kit)

**VC10/15TE STANDARD KIT**

**TOOL KIT**

- 1 x VC10/15TE Tool
- 2 x M48 Collets
- 2 x M52 Collets
- 2 x M56 Collets
- 1 x Instruction Manual
- 1 x Carry-Case with foam inserts

Carry-Case Dimensions:  
550 mm x 1200 mm x 170 mm (21.7" x 47.2" x 6.7")  
Tool Kit Weight: 53.0 kg (116.8 lb)

**PUMP KIT**

- 1 x HP550S Hydraulic Hand Pump
- 1 x Hydraulic Gauge with manifold
- 1 x 2.0 m (78.74") Hydraulic Hose
- 1 x Secure Grip Safety Block
- 1 x 1/2" Square Drive Flexible Handle with 30 mm Socket
- 1 x Vernier Caliper
- 1 x Instruction Manual
- 1 x Carry-Case with foam inserts

Carry-Case Dimensions:  
550 mm x 1200 mm x 170 mm (21.7" x 47.2" x 6.7")  
Pump-Kit Weight: 27.0 kg (59.5 lb)



Gross Kit Weight: 80.0 kg (176.4 lb)  
(Tool-Kit and Pump-Kit)

**VC10/15TE MAXI KIT**

**TOOL KIT (2 PER MAXI KIT)**

- 1 x VC10/15TE Tool
- 2 x M48 Collets
- 2 x M52 Collets
- 2 x M56 Collets
- 1 x Instruction Manual
- 1 x Carry-Case with foam inserts

Carry-Case Dimensions:  
550 mm x 1200 mm x 170 mm (21.7" x 47.2" x 6.7")  
Tool Kit Weight: 53.0 kg (116.8 lb)

**PUMP KIT**

- 1 x HP1000D Hydraulic Hand Pump
- 2 x Hydraulic Gauge with manifold
- 2 x 2.0 m (78.74") Hydraulic Hose
- 2 x Secure Grip Safety Block
- 1 x 1/2" Square Drive Flexible Handle with 30 mm Socket
- 1 x Vernier Caliper
- 1 x Instruction Manual
- 1 x Carry-Case with foam inserts

Carry-Case Dimensions:  
550 mm x 1200 mm x 170 mm (21.7" x 47.2" x 6.7")  
Pump-Kit Weight: 30.0 kg (66.1 lb)



Gross Kit Weight: 136.0 kg (299.8 lb)  
(Tool-Kits and Pump-Kit)

**VC10/18TE STANDARD KIT**

**TOOL KIT**

- 1 x VC10/18TE Tool
- 2 x M60 Collets
- 2 x M64 Collets
- 2 x M70 Collets
- 1 x Instruction Manual
- 1 x Carry-Case with foam inserts

Carry-Case Dimensions:  
550 mm x 1200 mm x 170 mm (21.7" x 47.2" x 6.7")  
Tool Kit Weight: 58.0 kg (127.9 lb)

**PUMP KIT**

- 1 x HP550S Hydraulic Hand Pump
- 1 x Hydraulic Gauge with manifold
- 1 x 2.0 m (78.74") Hydraulic Hose
- 1 x Secure Grip Safety Block
- 1 x 1/2" Square Drive Flexible Handle with 30 mm Socket
- 1 x Vernier Caliper
- 1 x Instruction Manual
- 1 x Carry-Case with foam inserts

Carry-Case Dimensions:  
550 mm x 1200 mm x 170 mm (21.7" x 47.2" x 6.7")  
Pump-Kit Weight: 27.0 kg (59.5 lb)



Gross Kit Weight: 85.0 kg (187.4 lb)  
(Tool-Kit and Pump-Kit)

**VC10/18TE MAXI KIT**

**TOOL KIT (2 PER MAXI KIT)**

- 1 x VC10/18TE Tool
- 2 x M60 Collets
- 2 x M64 Collets
- 2 x M70 Collets
- 1 x Instruction Manual
- 1 x Carry-Case with foam inserts

Carry-Case Dimensions:  
550 mm x 1200 mm x 170 mm (21.7" x 47.2" x 6.7")  
Tool Kit Weight: 58.0 kg (127.9 lb)

**PUMP KIT**

- 1 x HP1000D Hydraulic Hand Pump
- 2 x Hydraulic Gauge with manifold
- 2 x 2.0 m (78.74") Hydraulic Hose
- 2 x Secure Grip Safety Block
- 1 x 1/2" Square Drive Flexible Handle with 30 mm Socket
- 1 x Vernier Caliper
- 1 x Instruction Manual
- 1 x Carry-Case with foam inserts

Carry-Case Dimensions:  
550 mm x 1200 mm x 170 mm (21.7" x 47.2" x 6.7")  
Pump-Kit Weight: 30.0 kg (66.1 lb)



Gross Kit Weight: 146.0 kg (321.9 lb)  
(Tool-Kits and Pump-Kit)

**VC10/25TE STANDARD KIT**

**TOOL KIT**

- 1 x VC10/25TE Tool
- 1 x Instruction Manual
- 1 x Hard Case

COLLETS (Available Separately)

- |                 |                  |
|-----------------|------------------|
| 2 x M76 Collets | 2 x M90 Collets  |
| 2 x M80 Collets | 2 x M95 Collets  |
| 2 x M84 Collets | 2 x M100 Collets |

Box Dimensions:

550 mm x 1200 mm x 170 mm (21.7" x 47.2" x 6.7")

Tool Kit Weight: 58.0 kg (127.9 lb)

**PUMP KIT**

- 1 x HP550S Hydraulic Hand Pump
- 1 x Hydraulic Gauge with manifold
- 1 x 2.0 m (78.74") Hydraulic Hose
- 1 x Secure Grip Safety Block
- 1 x 1/2" Square Drive Flexible Handle with 30 mm Socket
- 1 x Vernier Caliper
- 1 x Instruction Manual
- 1 x Hard Case

Box Dimensions:

550 mm x 1200 mm x 170 mm (21.7" x 47.2" x 6.7")

Pump-Kit Weight: 27.0 kg (59.5 lb)



Gross Kit Weight: 85.0 kg (187.4 lb)  
(Tool-Kit and Pump-Kit)

**VC10/25TE MAXI KIT**

**TOOL KIT (2 PER MAXI KIT)**

- 1 x VC10/25TE Tool
- 1 x Instruction Manual
- 1 x Hard Case

COLLETS (Available Separately)

- |                 |                  |
|-----------------|------------------|
| 2 x M76 Collets | 2 x M90 Collets  |
| 2 x M80 Collets | 2 x M95 Collets  |
| 2 x M84 Collets | 2 x M100 Collets |

Box Dimensions:

550 mm x 1200 mm x 170 mm (21.7" x 47.2" x 6.7")

Tool Kit Weight: 58.0 kg (127.9 lb)

**PUMP KIT**

- 1 x HP1000D Hydraulic Hand Pump
- 2 x Hydraulic Gauge with manifold
- 2 x 2.0 m (78.74") Hydraulic Hose
- 2 x Secure Grip Safety Block
- 1 x 1/2" Square Drive Flexible Handle with 30 mm Socket
- 1 x Vernier Caliper
- 1 x Instruction Manual
- 1 x Hard Case

Box Dimensions:

550 mm x 1200 mm x 170 mm (21.7" x 47.2" x 6.7")

Pump-Kit Weight: 30.0 kg (66.1 lb)



Gross Kit Weight: 146.0 kg (321.9 lb)  
(Tool-Kits and Pump-Kit)

# 6.

## TROUBLESHOOTING

### 6.1

#### VC10/13TE, VC10/15TE, VC10/18TE, VC10/25TE TROUBLESHOOTING

#### **HOSES ARE CONNECTED BUT THE TOOL DOES NOT ADVANCE. THE PRESSURE ON THE PUMP HANDLE IS MINIMAL**

**POSSIBLE CAUSE:**

The Release valve is in the retract (open) position (and the control valves are open on the HP1000D).

**RECOMMENDED ACTION:**

Close the release valve (and the control valves on the HP1000D).



#### **HOSES ARE CONNECTED AND THE PUMP QUICKLY REACHES MAXIMUM PRESSURE BUT THE TOOL HAS NOT ADVANCED**

**POSSIBLE CAUSE:**

One or more of the connectors are not fully tightened and the hydraulic oil cannot pass through from the pump to the cylinder.

**RECOMMENDED ACTION:**

Check all connectors are fully tightened and the release valve is in the fully closed position.

#### **HOSES ARE CONNECTED AND THE TOOL ADVANCES WITH MAXIMUM PRESSURE ON THE PUMP HANDLE BUT THE JOINT WILL NOT SPREAD**

**POSSIBLE CAUSE:**

The pressure required to spread the joint is greater than that of the tool(s) you are using.

**RECOMMENDED ACTION:**

Add another one or two tools and distribute them equally around the joint (120° apart with 3 tools and 90° apart with 4 tools) and try again.

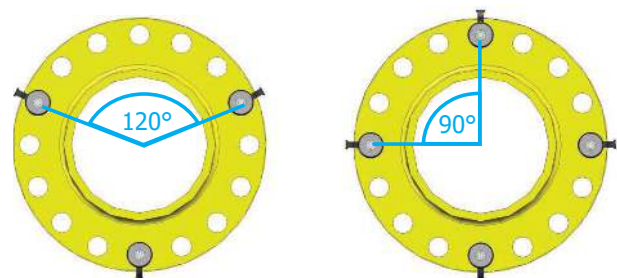

#### **HOSES ARE CONNECTED AND THE TOOL ADVANCES BUT THERE IS MINIMAL PRESSURE ON THE PUMP HANDLE AND THE HANDLE IS RISING BACK ON ITS OWN ACCORD**

**POSSIBLE CAUSE:**

There is dirt or a damaged valve seat within the pump unit.

**RECOMMENDED ACTION:**

The pump should be sent to an authorised Equalizer distributor for repair.

**HOSES ARE CONNECTED AND THE TOOL ADVANCES AS THE PUMP IS PRIMED BUT THE PRESSURE ON THE PUMP HANDLE IS MINIMAL AND FEELS SPONGY.**

**POSSIBLE CAUSE:**

Air could be present in the hydraulic system.

**RECOMMENDED ACTION:**

Follow the airlock removal procedure:

1. Connect the hand pump to the tool with the hydraulic hose.
2. Close the release valve on the pump, and prime the pump until the hydraulic cylinder is fully extended and a small pressure is achieved.
3. With the hand pump held above the tool and the tool held in an upright position, open the release valve. Any air that is within the system will be forced up through the pump and vented into the oil reservoir.
4. Repeat steps 1 - 3 three or four times to ensure that all air is removed from the system and the tool will reach full working pressure.
5. Disconnect the hand pump from the hydraulic hose, grip the baseplate of the hand pump body in a vice with the pump body vertical and the main handle at the top.
6. Remove the four nuts holding the main handle and lift off.
7. Grip the refilling plug with pliers and extract it by pulling and twisting simultaneously. Ensure the reservoir body is held down when removing the refilling plug as pulling up on the reservoir body will release the bladder within, and oil will spill out.
8. Fill the reservoir to the top with a good quality hydraulic oil of the grade 15 cSt.
9. Reinsert the refilling plug, wipe away any oil and reassemble by reversing the disassembly process.

**AIRLOCK REMOVAL PROCEDURE:**

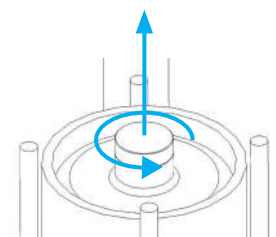
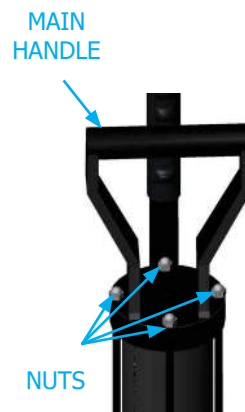
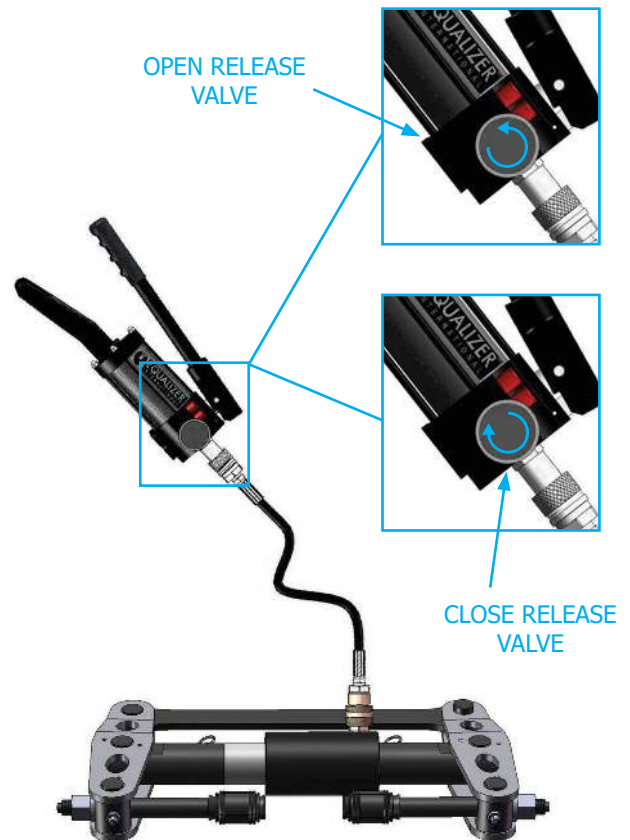



## ONE COLLET IS JAMMED IN A BOLT HOLE.

### POSSIBLE CAUSE:

A collet which is too small or large has been selected, or the collet has been inserted into a damaged or non-round bolt hole.

### RECOMMENDED ACTION:

Removal can be achieved as follows:

1. Pull the collet spring plunger ring out, and remove the rest of the tool, leaving the collet head assembly in the bolt hole.
2. Unscrew the collet nut and remove the drive cone and collet cone.
3. Screw the collet nut back onto the collet holder until it is 1 - 2 mm off the end.
4. Using a hammer and a suitable drift, move the collet holder until the collet nut is against the flange.
5. Remove the collet nut and push the collet holder through the flange and out of the other end of the bolt hole.
6. Drive the collet out using the collet holder.

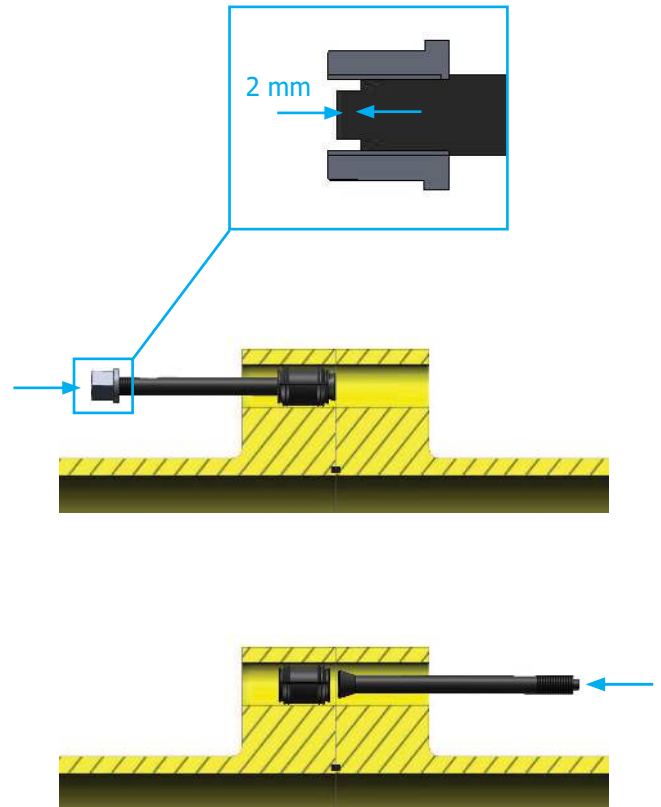

## A PAIR OF COLLETS ARE JAMMED IN A BOLT HOLE.

### POSSIBLE CAUSE:

A collet which is too small or large has been selected, or the collet has been inserted into a damaged or non-round bolt hole.

### RECOMMENDED ACTION:

The flange must be spread before removal can be attempted. This can be done using another pair of Secure Grip tools, or another method if available. Removal can be achieved as follows:

1. On both sides, pull the collet spring plunger ring out, and remove the rest of the tool, leaving the collet head assemblies in the bolt hole.
2. On both sides, unscrew the collet nut and remove the drive cone and collet cone.
3. On the left-hand side, screw the collet nut back on to the collet holder until it is 1 - 2 mm off the end.
4. Using a hammer and a suitable drift, move the collet holder until it is possible to cut off the tapered end of the collet holder.
5. Cut off the tapered end with a hack saw or other cutting tool.
6. Withdraw the collet holder from the bolt hole.
7. Using a hammer and a suitable drift, move the collet holder on the right-hand side up to the left-hand side collet and drive it out.
8. Drive the right-hand side collet out using the collet holder.

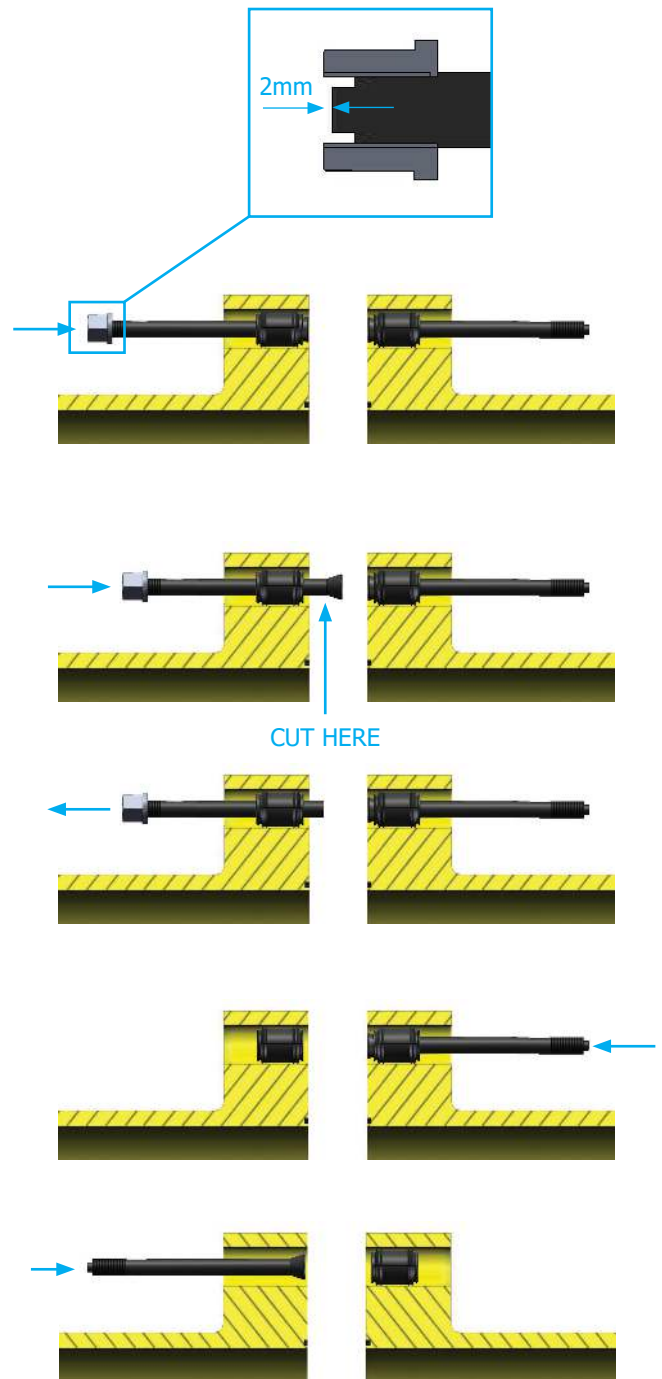

# 7.

## REGULATORY INFORMATION

### 7.1

#### REGISTERED HEAD OFFICE

EQUALIZER INTERNATIONAL LTD.  
Equalizer House  
Claymore Drive  
Aberdeen  
Scotland  
AB23 8GD

### 7.2

#### APPLICABLE PATENT NUMBERS

The following list of Patents are applicable to EQUALIZER INTERNATIONAL LTD Secure-Grip tools:

#### **REGISTERED PATENTS**

- WO2007/003937
- ZL200680024272.9
- 06764895.6
- 013621
- 8322009
- 298634

# 8.

## **PARTS LISTS & SERVICE KITS**

**VC10/13TE PARTS LIST**

ITEM NO.	PART NO	DESCRIPTION	QTY.
1	880100-01	LEG ASSEMBLY	2
2	860200-01	TENSION BAR ASSEMBLY	1
3	880300-01	COLLET ASSEMBLY	2
4	860400-01	ACTUATOR EXTENSION SHORT	1
5	860500-01	ACTUATOR EXTENSION LONG	1
6	900502-01	PULL PIN M10	2
7	880800-01	VC10/13TE ACTUATOR STICKER	1
8	880900-01	SERIAL PLATE	1
9	644001-01	ACTUATOR	1

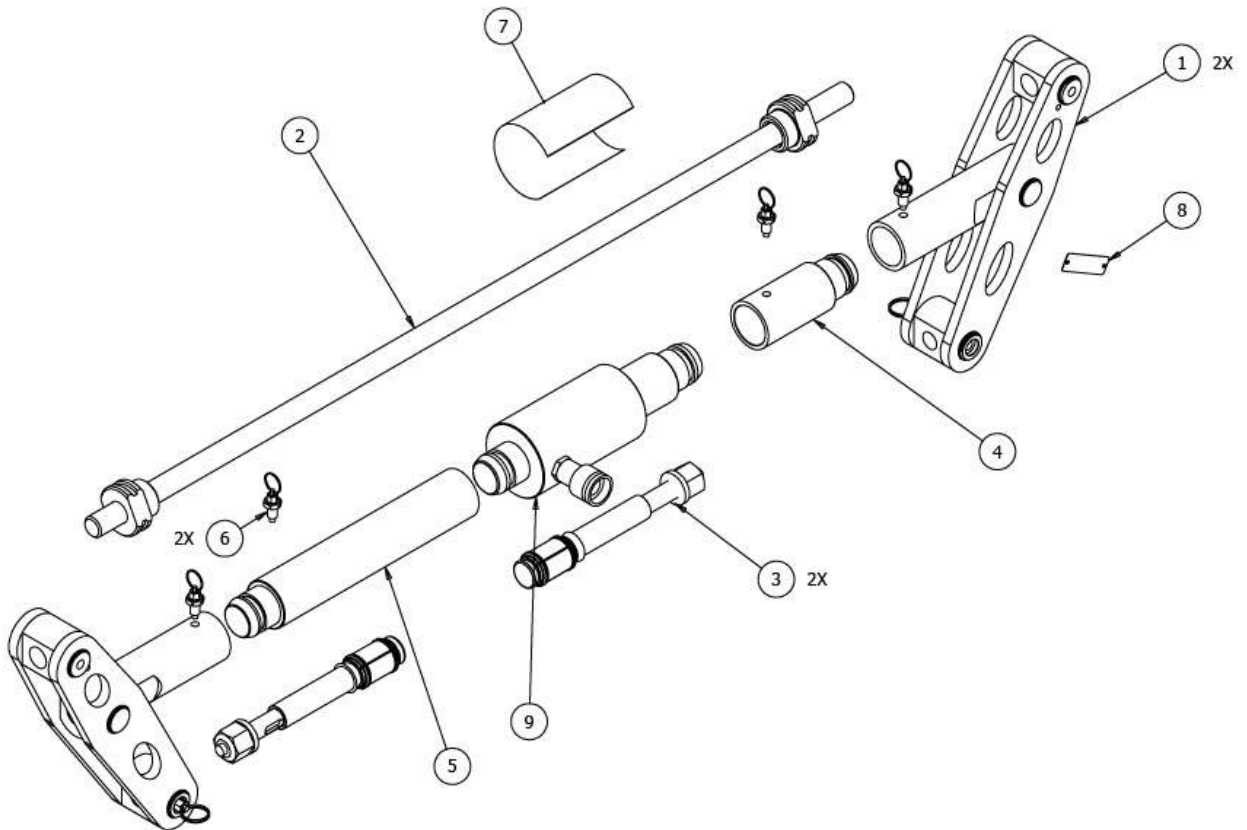

**VC10/13TE COLLET ASSEMBLY PARTS LIST**

ITEM NO.	PART NO	DESCRIPTION	QTY.
1	640901-01	M20X2.5 COLLAR NUT	1
2	641601-01	DRIVE TUBE	1
3	640501-01	DRIVE CONE	1
4	640401-01	COLLET HOLDER	1
5	640101-01	M39 COLLET	OPTION
6	640201-01	M42 COLLET	OPTION
7	640301-01	M45 COLLET	OPTION

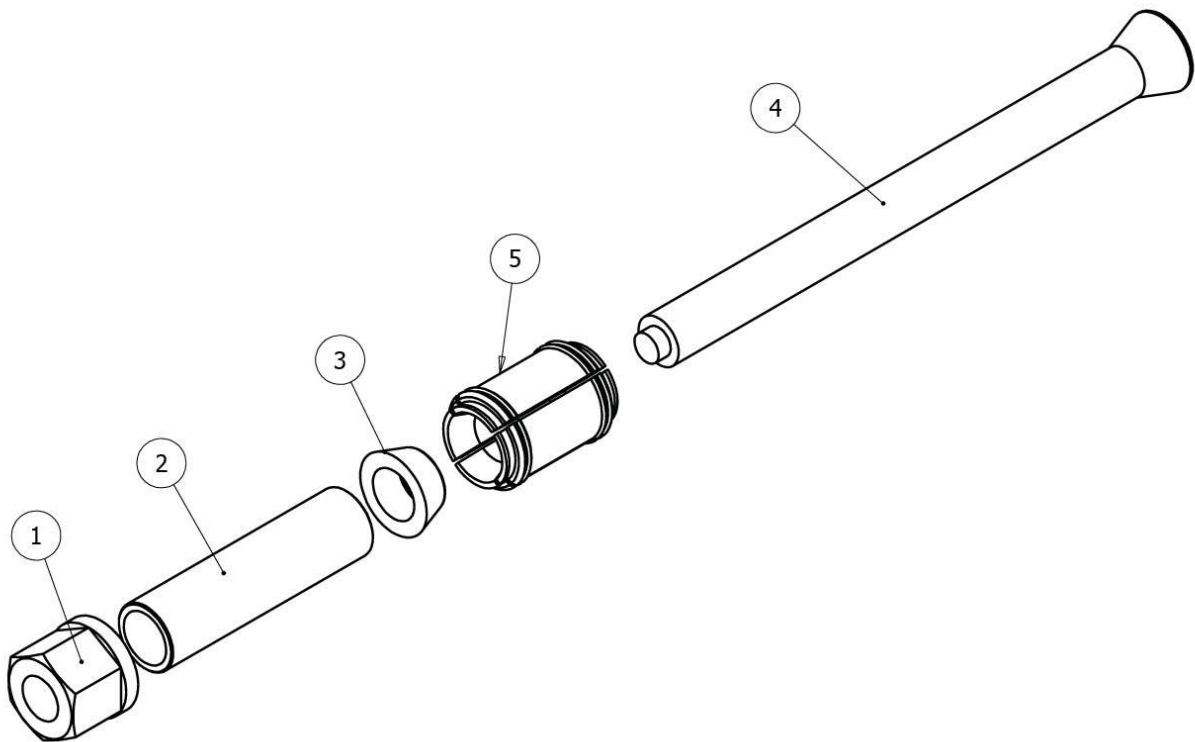

**VC10/13TE LEG ASSEMBLY PARTS LIST**

ITEM NO.	PART NO	DESCRIPTION	QTY.
1	880101-01	COLLET UNION	1
2	651901-01	ACTUATOR UNION	1
3	650601-01	COLLET UNION	1
4	651401-01	ACTUATOR PIN	1
5	860101-01	VC10TE LEG-MACHINED	2
6	641301-01	SPIROL RETAINING RING	6
7	900502-01	PULL PIN M10	1
8	641001-01	M12 PLUNGER	1

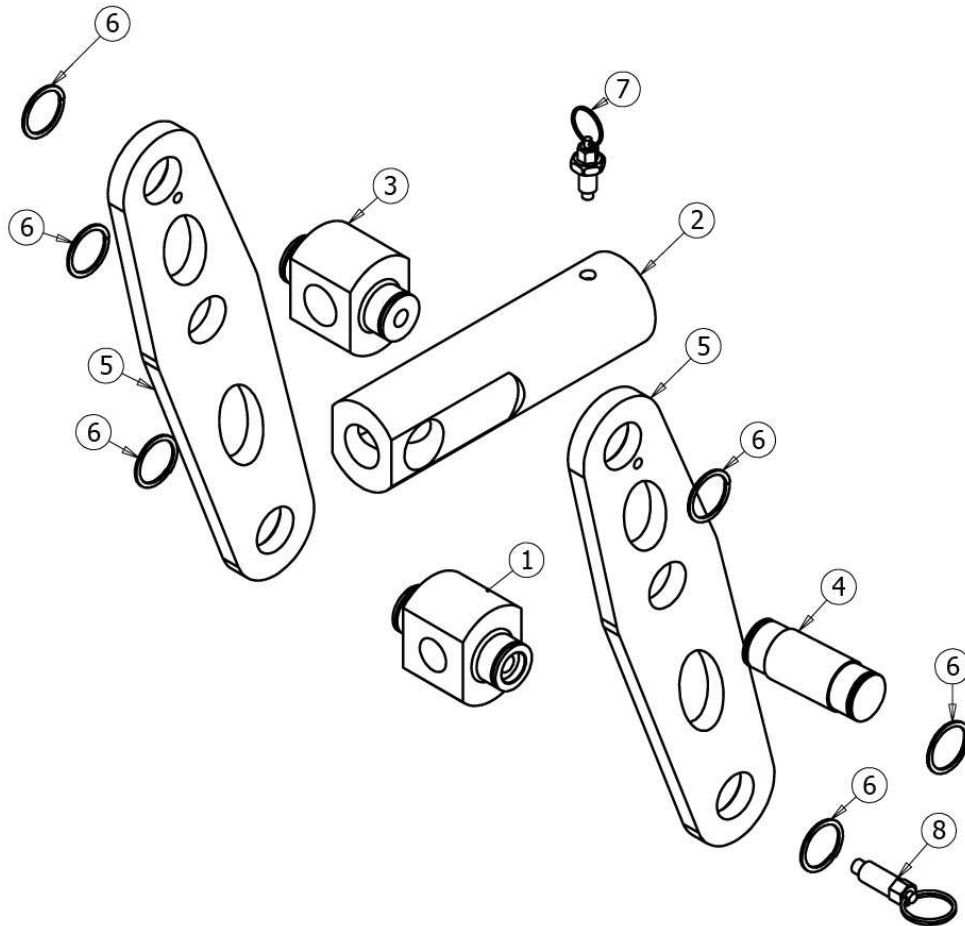

**VC10/15TE PARTS LIST**

ITEM NO.	PART NO	DESCRIPTION	QTY.
1	860100-01	LEG ASSEMBLY	2
2	860200-01	TENSION BAR ASSEMBLY	1
3	870300-01	COLLET ASSEMBLY	2
4	860500-01	ACTUATOR EXTENSION (283.5mm)	1
5	860400-01	ACTUATOR EXTENSION (98.5mm)	1
6	900502-01	PULL PIN M10	2
7	070404-01	VC10/15TE ACTUATOR STICKER	1
8	870900-01	SERIAL PLATE	1
9	644001-01	ACTUATOR	1

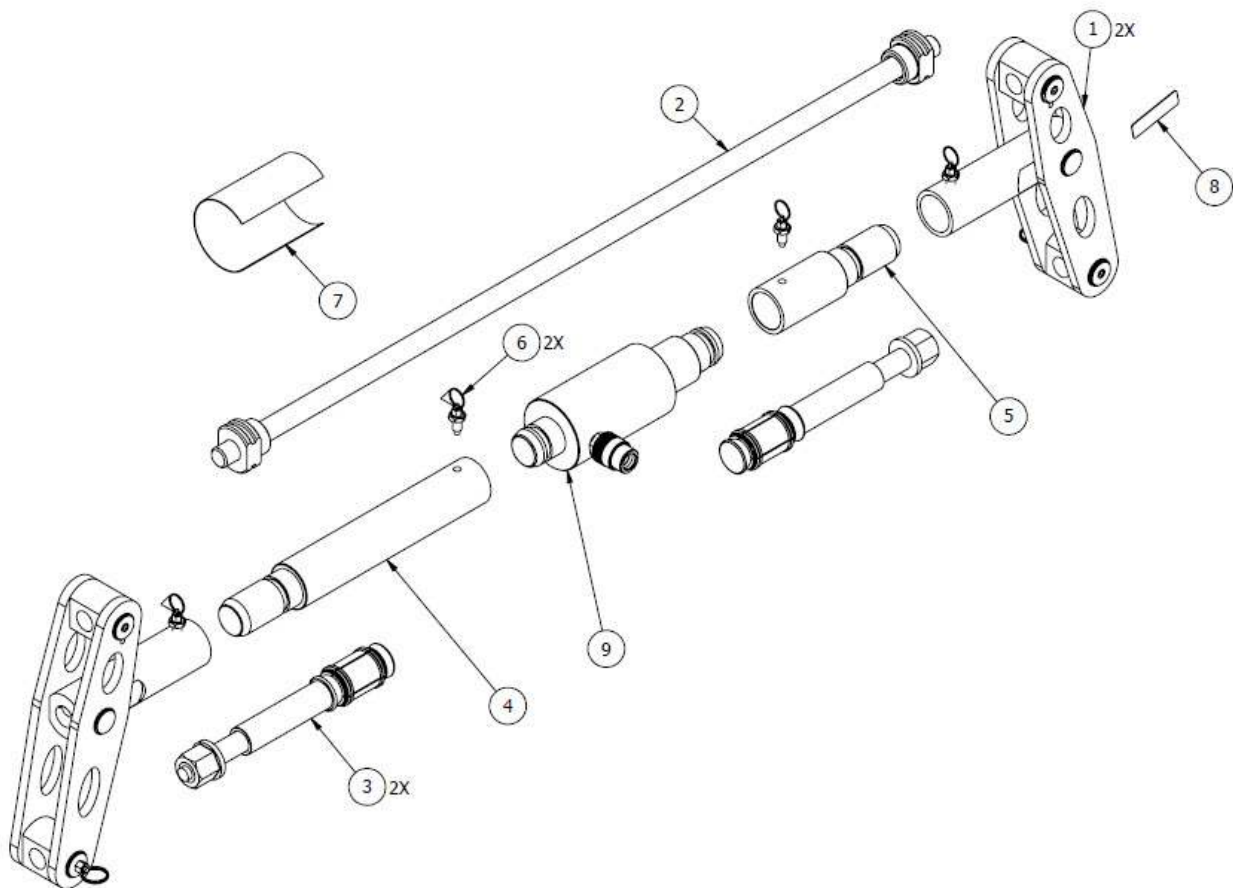



**VC10/15TE COLLET ASSEMBLY PARTS LIST**

ITEM NO.	PART NO	DESCRIPTION	QTY.
1	650901-01	COLLET NUT (M24)	1
2	651601-01	DRIVE TUBE	1
3	650501-01	DRIVE CONE	1
4	650401-01	COLLET HOLDER	1
5	650301-01	M56 COLLET	OPTION
6	650101-01	M48 COLLET	OPTION
7	650201-01	M52 COLLET	OPTION

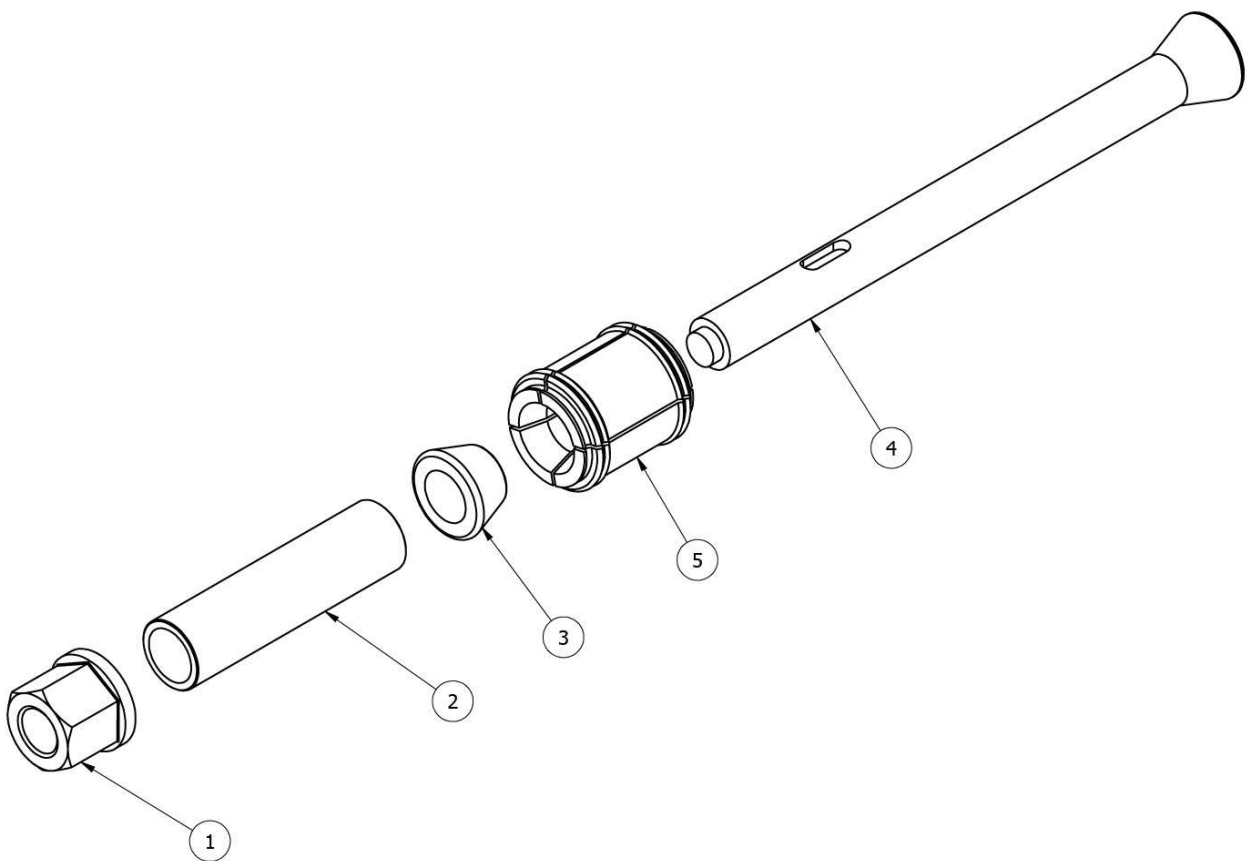

**VC10/18TE PARTS LIST**

ITEM NO.	PART NO	DESCRIPTION	QTY.
1	860100-01	LEG ASSEMBLY	2
2	860200-01	TENSION BAR ASSEMBLY	1
3	860300-01	COLLET ASSEMBLY	2
4	860500-01	ACTUATOR EXTENSION LONG	1
5	860400-01	ACTUATOR EXTENSION SHORT	1
6	900502-01	PULL PIN M10	2
7	070401-01	VC10TE ACTUATOR STICKER	1
8	860900-01	SERIAL PLATE	1
9	644001-01	ACTUATOR	1

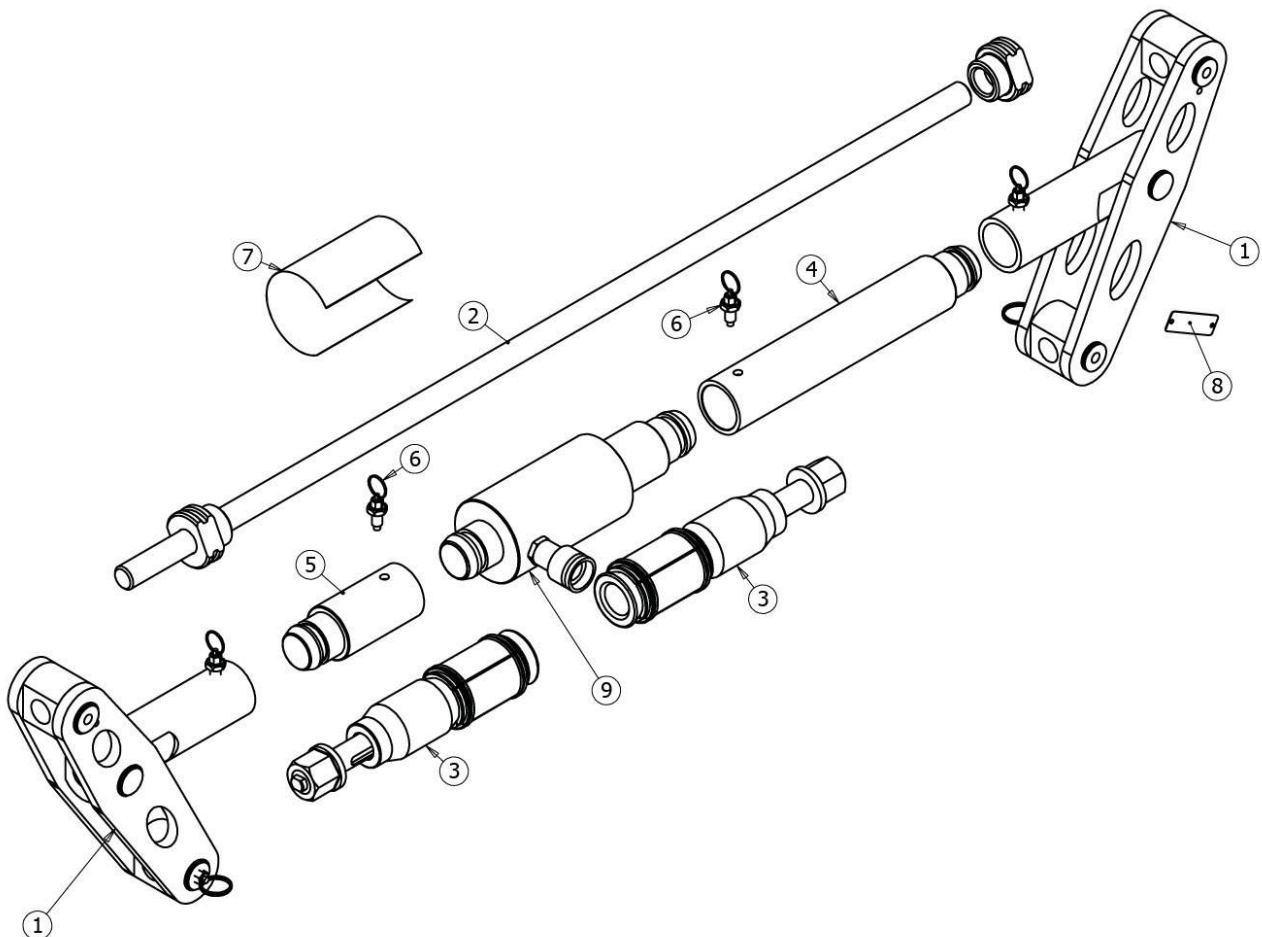

**VC10/18TE COLLET ASSEMBLY PARTS LIST**

ITEM NO.	PART NO	DESCRIPTION	QTY.
1	650901-01	COLLET NUT (M24)	1
2	860302-01	DRIVE CONE	1
3	860301-01	COLLET HOLDER	1
4	663401-01	M64 COLLET	OPTION
5	663001-01	M60 COLLET	OPTION
6	663601-01	M70 COLLET	OPTION

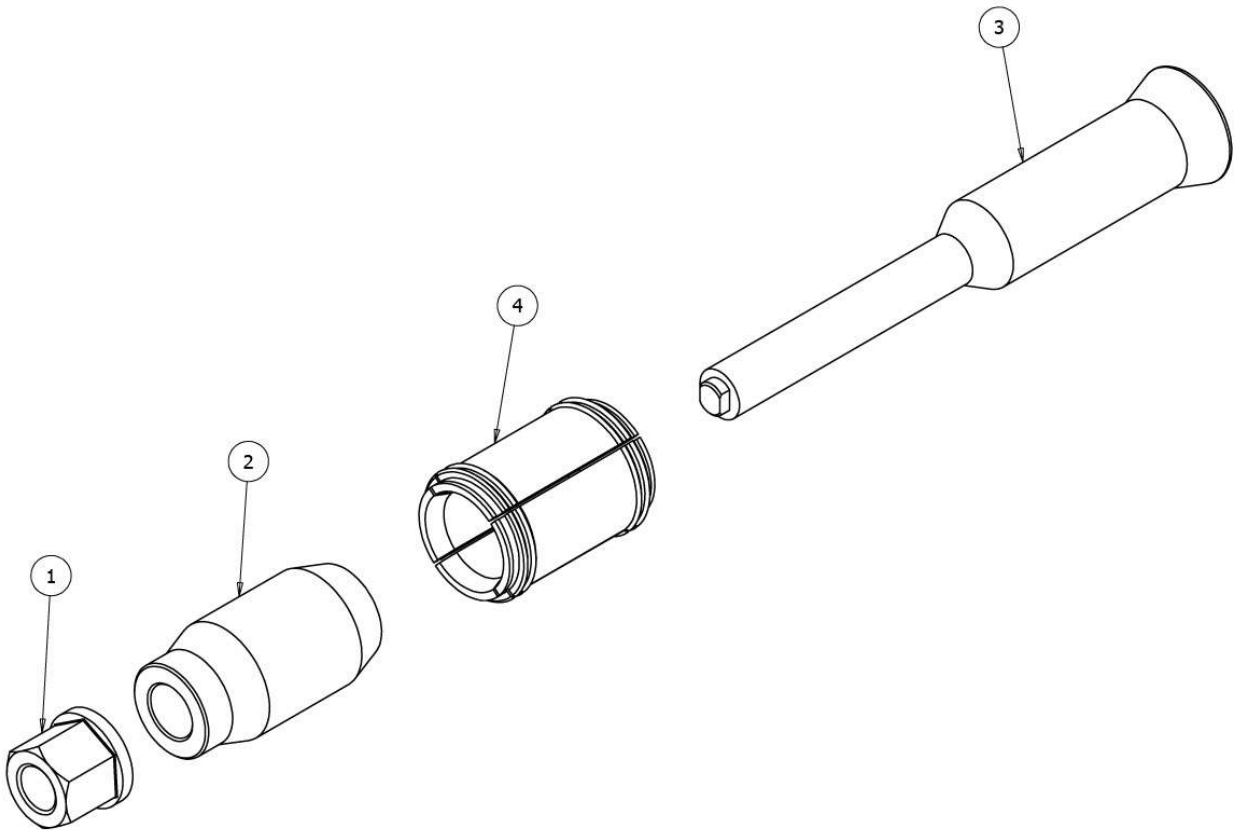

**VC10/15TE & 18TE & 25TE LEG ASSEMBLY PARTS LIST**

ITEM NO.	PART NO	DESCRIPTION	QTY.
1	650601-01	COLLET UNION	1
2	651901-01	ACTUATOR UNION	2
3	651401-01	ACTUATOR PIN	1
4	860101-01	VCIOTE LEG-MACHINED	2
5	641301-01	SPIROL RETAINING RING	6
6	900502-01	PULL PIN MIO	1
7	641001-01	M12 PLUNGER	1

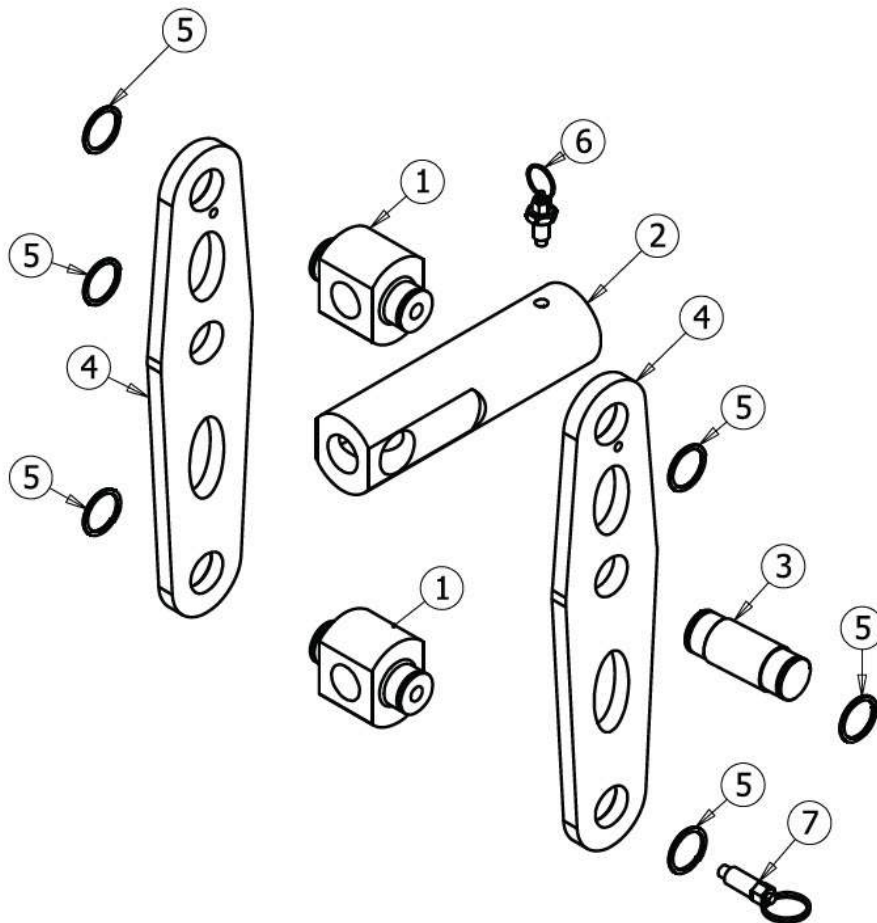

**VC10/25TE PARTS LIST**

ITEM NO.	PART NO	DESCRIPTION	QTY.
1	860100-01	LEG ASSEMBLY	2
2	860200-01	TENSION BAR ASSEMBLY	1
3	860500-01	ACTUATOR EXTENSION LONG	1
4	860400-01	ACTUATOR EXTENSION SHORT	1
5	644001-01	ACTUATOR	1
6	1200100-01	COLLET ASSEMBLY	2
7	900502-01	PULL PIN M10	2
8	1200001-01	ACTUATOR STICKER	1
9	1200002-01	SERIAL PLATE	1

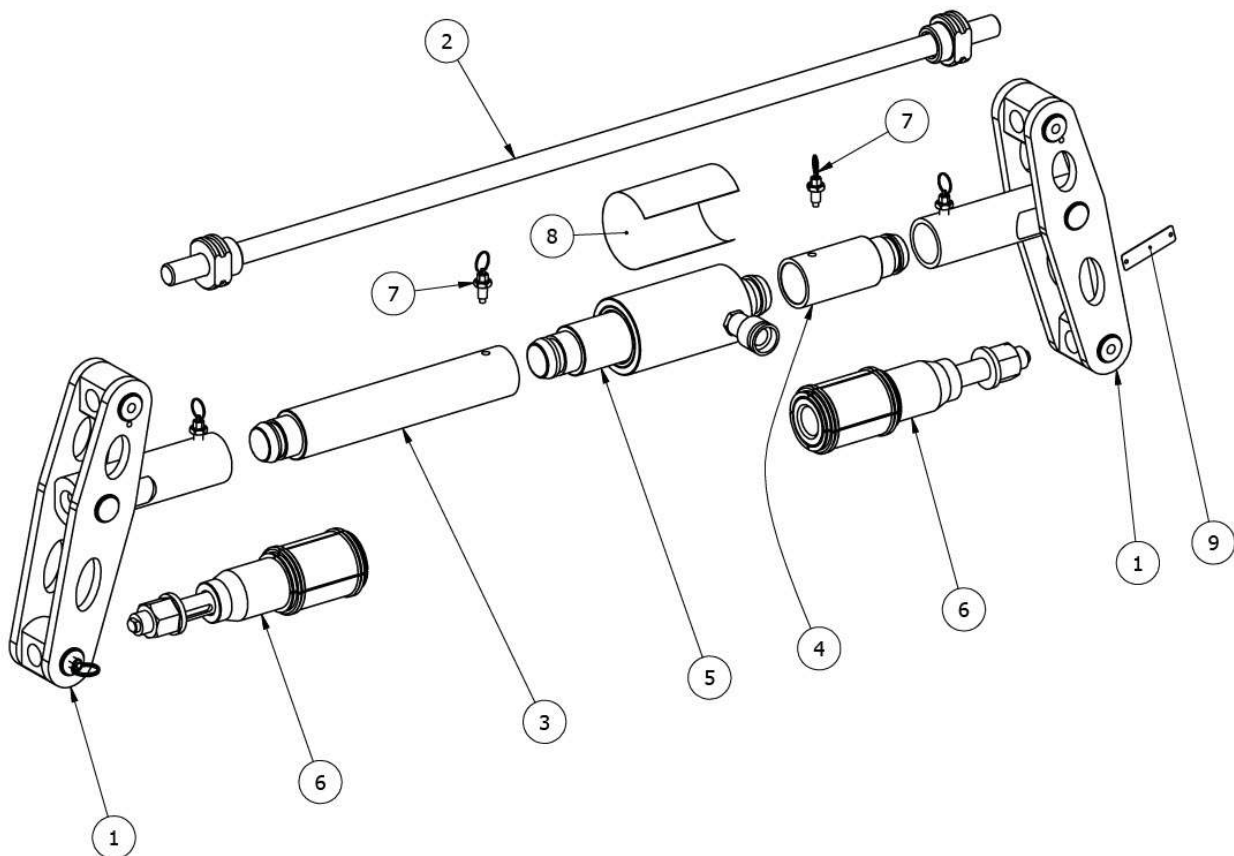

**VC10/25TE COLLET ASSEMBLY PARTS LIST**

ITEM NO.	PART NO	DESCRIPTION	QTY.
1	650901-01	COLLET NUT (M24)	1
2	860302-01	DRIVE CONE	1
3	860301-01	COLLET HOLDER	1
4	673601-01	M76 COLLET	OPTION
	673901-01	M80 COLLET	OPTION
	674501-01	M84 COLLET	OPTION
	674801-01	M90 COLLET	OPTION
	675101-01	M95 COLLET	OPTION
	675601-01	M100 COLLET	OPTION

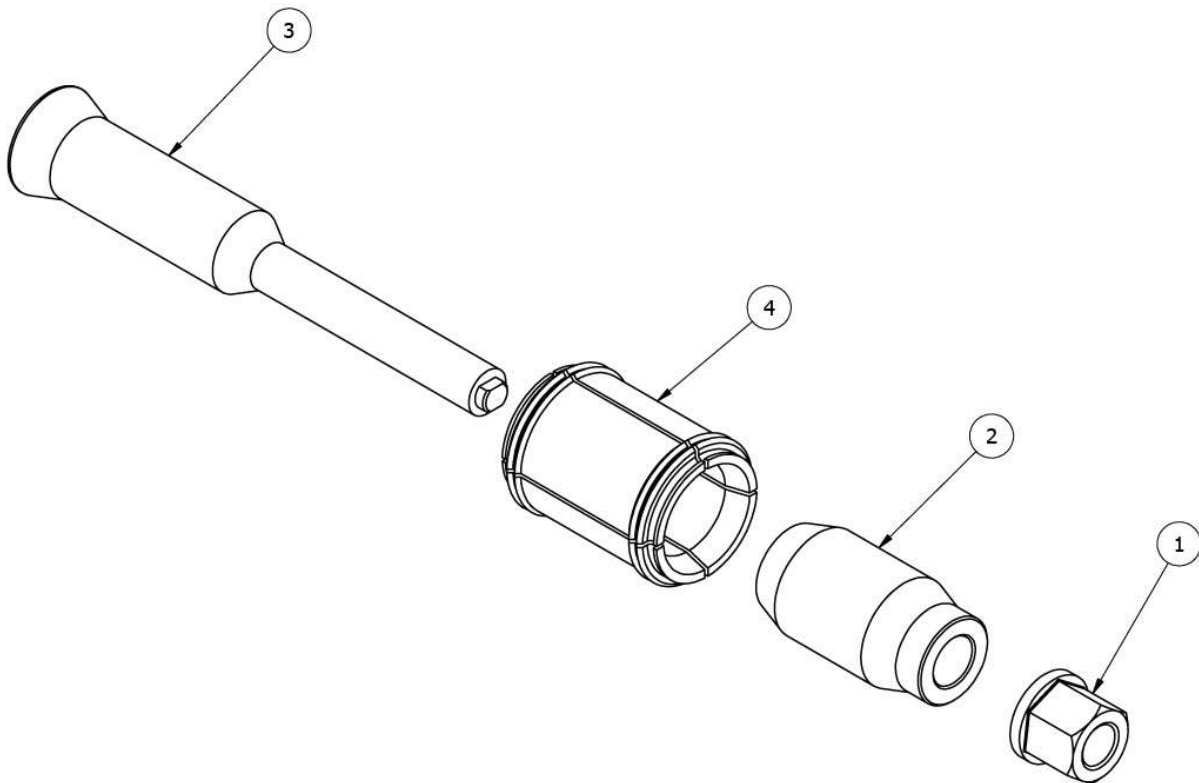

**TENSION BAR ASSEMBLY PARTS LIST**

ITEM NO.	PART NO	DESCRIPTION	QTY.
1	860201-01	TENSION BAR	1
2	860202-01	THUMB NUT	2

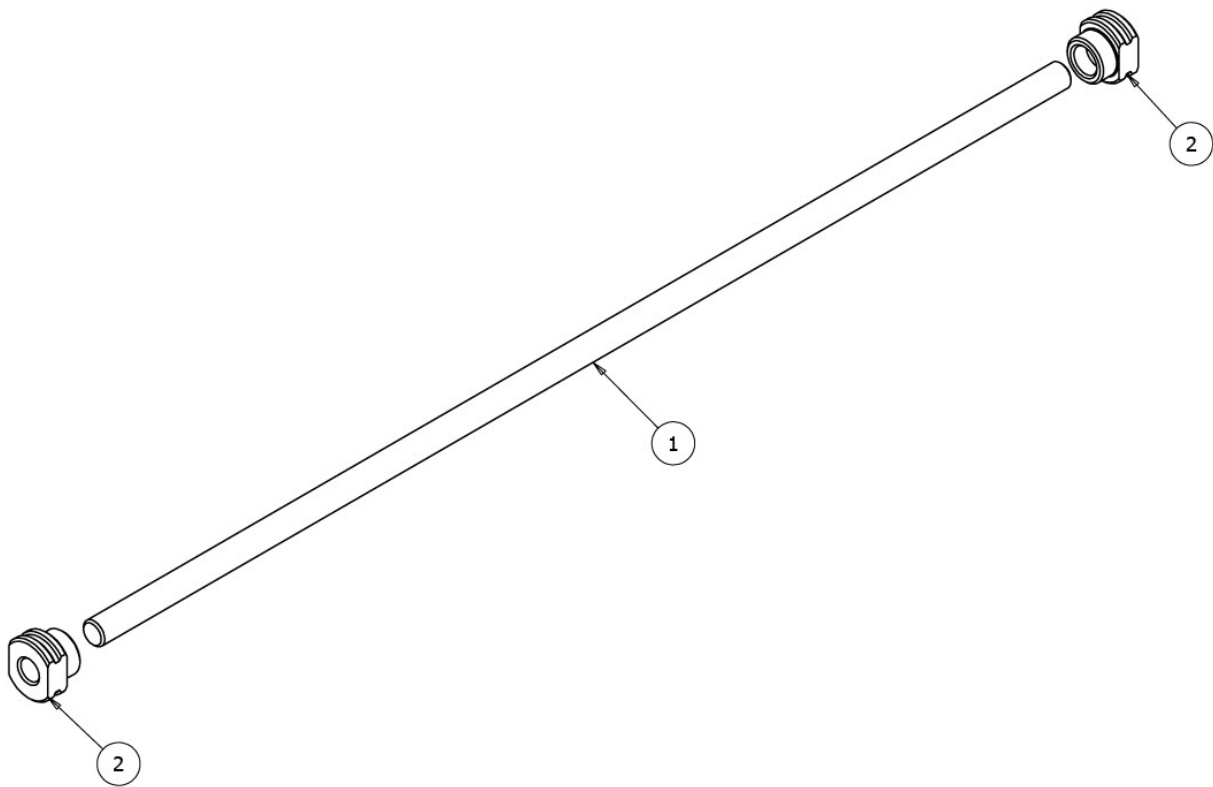



**EQUALIZER**<sup>TM</sup>  
AN ENERPAC BRAND



EQUALIZER INTERNATIONAL LTD.

Head Office  
Equalizer House  
Claymore Drive  
Aberdeen  
Scotland  
UK

AB23 8GD

t: +44 (0) 1224 701970

f: +44 (0) 1224 823791

[www.equalizerinternational.com](http://www.equalizerinternational.com)