

LPL-Series, Low-Height Lock Nut Cylinders



▼ LPL-Series, Low-Height Lock Nut Cylinders



- Lock nut provides mechanical load holding for a safe work environment
- Integrated tilt saddle allows for up to 5 degrees of misalignment
- Extreme low height for use in confined areas
- Side-load resistance 5-10% of maximum capacity
- Overflow port as stroke limiter to prevent plunger blow-out
- Single-acting, gravity-return.

▼ Only the extreme low-height LPL-cylinder fits in this confined area to lift the construction. The lock nut provides positive and safe mechanical load holding over a long period of time.



Torque and tension specialist



Integrated Tilt Saddles

All LPL-Series cylinders include integral tilt saddles with maximum tilt angles up to 5°.



The Summit Edition

Innovation is at the heart of the new Summit Edition of cylinders, delivering the high quality construction that you expect from Enerpac. The durability ensures your job gets done safely and reliably.

- Replaceable plunger support bearing adds support for eccentric loads *
- Nitrocarburization surface treatment for improved load and wear resistance and corrosion protection
- Low wear, high pressure seals provide longer service life.

* Eccentric load (or "side-load") is inevitable in heavy lifting. Our unique Summit Edition features provide the ultimate protection against side load. Increased bearing surface maintains stability and nitrocarburization treatment prevents scoring on the inside of the cylinder. Side-load poses a real problem.... our new cylinder features are the solution!

Page: 40

Cylinder Capacity	Stroke	Model Number	Maximum Cylinder Capacity at 700 bar ton (kN)	Side-load Resistance of Maximum Capacity	Cylinder Effective Area
ton	(mm)				(cm ²)
60	50	LPL-602	62 (606)	10%	86,6
100	50	LPL-1002	102 (1002)	10%	143,1
150	45	LPL-1602	162 (1589)	8%	227,0
200	45	LPL-2002	202 (1985)	8%	283,5
250	45	LPL-2502	259 (2541)	5%	363,1
400	45	LPL-4002	409 (4008)	5%	572,6
500	45	LPL-5002	522 (5114)	5%	730,6

Single-Acting, Low-Height Lock Nut Cylinders



IMPORTANT!

All LPL-Series cylinders require a solid lifting surface for correct support. The use of these cylinders on surfaces such as sand, mud or dirt, may result in cylinder damage.

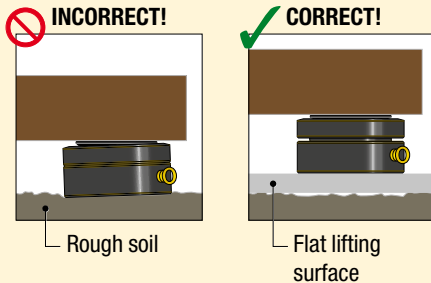

For more safety instructions see our 'Learning Center' on www.enerpac.com

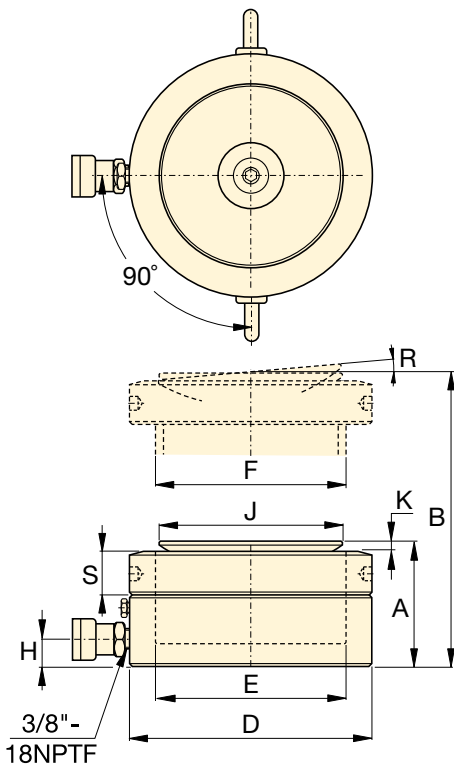

LPL Series



Capacity:

60 - 500 ton

Stroke:

45 - 50 mm

Maximum Operating Pressure:

700 bar



Longer Stroke Lock Nut Cylinders

For longer stroke applications **HCL and HCRL-Series** lock nut cylinders are the perfect choice.

Page: 42



Split-Flow Pumps

SFP-Series Pumps with multiple outlets with equal oil flow. For lifting and lowering applications on multiple points

these pumps are a far better alternative than using separately operated pumps.

Page: 240



Synchronous Lifting Systems

Pumps for multiple lift point capabilities. The economical **EVOB-Series** for basic applications and the multi-functional **EVO-Series** lifting system.

Page: 242

Oil Capacity	Collapsed Height	Extended Height	Outside Diameter	Cylinder Bore Diameter	Plunger Diameter	Base to Advance Port	Saddle Diameter	Saddle Protrusion from Plgr.	Saddle Max. Tilt Angle	Lock Nut Height	 (kg)	Model Number
(cm ³)	A (mm)	B (mm)	D (mm)	E (mm)	F (mm)	H (mm)	J (mm)	K (mm)	R	S (mm)		
433,0	126	176	140	105	Tr 105 x 4	19	96	7	5°	28	15	LPL-602
715,7	137	187	173	135	Tr 135 x 6	21	126	8	5°	31	25	LPL-1002
1021,4	148	193	220	170	Tr 170 x 6	27	160	9	5°	40	43	LPL-1602
1275,9	155	200	245	190	Tr 190 x 6	30	180	10	5°	43	55	LPL-2002
1633,7	159	204	275	215	Tr 215 x 6	32	200	12	5°	43	70	LPL-2502
2576,5	178	223	350	270	Tr 270 x 6	40	250	12	4°	55	129	LPL-4002
3287,8	192	237	400	305	Tr 305 x 6	49	290	10	3°	61,5	183	LPL-5002