

SCJ-SERIES SELF-LOCKING CUBE JACKS

INCREMENTAL LIFTING SYSTEM WITH AUTOMATED MECHANICAL LOCKING



▼ SCJ-50, Enerpac Self-Locking Cube Jack



Incremental lifting system with automated mechanical locking



Why use Self-Locking Cube Jacks?

The Self-Locking Cube Jack is a safer, more efficient alternative to the jack-and-pack method with wooden cribbing.

The Cube Jack is derived from the proven Enerpac Jack-up System. The Cube Jack has a small footprint and is useable in confined spaces, providing heavy lift contractors with a stable lift up to 2-3 metres. The cribbing blocks are lightweight and can be handled manually.

- System is automatically mechanically locked after the lifting or lowering stroke
- Self-aligning steel cribbing blocks save time, improve side load, and eliminate the need for wooden cribbing materials
- Jobs are completed more efficiently due to simplified operation sequence with 50% less cycles than climbing jacks
- End block with adjustable swivel saddle allows fine adjustment during set-up: 50 mm screw extension
- Can be operated with Enerpac's 700 bar hydraulic power units
- Maximum sideload 1,5% at full extension
- Lloyds witness tested to 125% of maximum working load.



Markets & Applications

Applications with a minimum starting height of 494 or 558 mm and requirement to lift up to 2067 or 3006 mm.

- Power Generation - transformer jacking
- Mining - equipment maintenance
- Heavy Transport - vehicle unloading
- Oil & Gas - module jacking
- Construction - bridge jacking
- Industrial Movers - lifting, lowering and levelling of heavy equipment.

▼ Typical set-up with 4 Self-Locking Cube Jacks and cribbing blocks to lift a transformer (hydraulic power pack and hoses not shown).





Self-Locking Cube Jack

Easy-to-use, compact and portable jacking system that utilizes base lifting frames and self-aligning, lightweight steel cribbing blocks, instead of wooden cribbing materials.

Operation is simple:

1. Connect the Cube Jacks to the Enerpac Split-Flow Pump and select lifting mode on each base lifting frame.
2. Insert a cribbing block and actuate the Cube Jack until the cribbing block engages the lock mechanism.
3. Retract the jack and repeat the process until the desired lifting height is reached. For the lowering operation select lowering mode on each base lifting frame and reverse the process.

The Cube Jack End Block is equipped with an adjustable saddle for initial alignment with the load. All controls except for the main directional valve, which is on the hydraulic power unit, are included on the Cube Jack.

Manual cribbing block insertion

Cribbing blocks are easily managed by hand and the Cube Jack includes integrated fork pockets and lifting rings for effortless positioning.

Synchronous Lifting & Lowering

If synchronization is required, the Cube Jack can accommodate stroke sensors and be used with any Enerpac Computer Controlled Synchronous Lifting System.

SCJ Series



Capacity Per Cube Jack:

500 - 1000 kN

Maximum Lifting Height:

2067 - 3006 mm

Maximum Operating Pressure:

700 bar

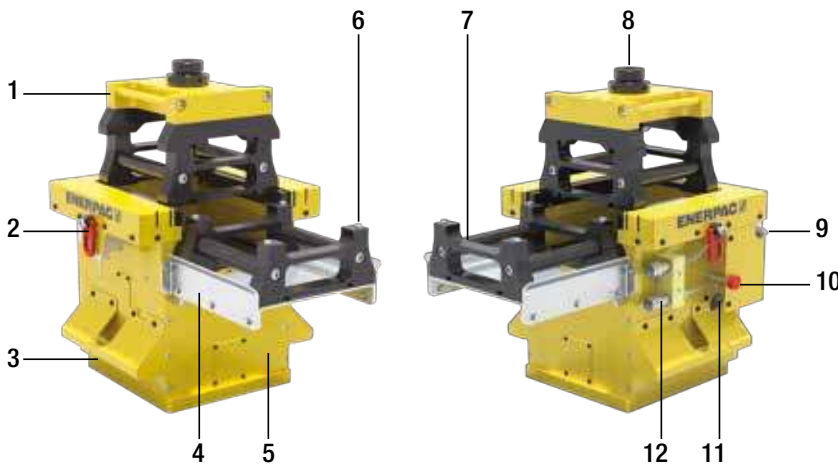

Self-Locking Cube Jack

- | | |
|---------------------------------|---|
| 1 End block with tilting saddle | 7 Steel cribbing blocks |
| 2 Eye-bolts for hoisting | 8 Adjustable tilting saddle |
| 3 Forklift tabs | 9 Flow control |
| 4 Removable insert table | 10 Mode locking pin |
| 5 Cube Jack base frame | 11 Mode selector lever |
| 6 Locating pins | 12 Hydraulic connections with CR-400 female half couplers (Advance / Retract) |



▲ Cube Jack close-up of lifting and lowering valving mode and lock handle.

▼ Optional wire stroke sensor can provide stroke feedback to pump control.



▼ SCJ-100, Enerpac Self-Locking Cube Jack



Included with the Cube Jack are:

- Cube Jack Basic Unit
- End Block with adjustable swivel saddle
- Multiple cribbing blocks: **11x on SCJ-50**
18x on SCJ-100
- Transportation Frame
- Cribbing blocks can be manually inserted into the Cube Jack by one person.

Incremental lifting system with automated mechanical locking



Transport Frame

Provided with purchase of each Cube Jack. Provides storage and transport for base unit, end block, and all included cribbing blocks.



Lightweight Cribbing Blocks

Provided with purchase of each Cube Jack. Cribbing blocks can be manually inserted into the Cube Jack by one person. Spare cribbing blocks can be ordered separately.

Description	Model Nr.
1x Cribbing Block, 50 ton	SCJ5B
1x Cribbing Block, 100 ton	SCJ10B



Split-Flow Pumps

Enerpac recommend to use the SFP-Series Pumps with multiple outlets with equal oil flow.

For lifting and lowering applications on multiple points, Split-Flow Pumps are a far better alternative than using separately operated pumps.

▼ Forklift tabs on Cube Jacks for easy transportation and positioning with a pallet truck. See dimensions D and I to select the right pallet truck size.



Self-Locking Cube Jacks

Lifting Capacity per Base Unit ton (kN)	Lifting Stroke (mm)	Model Number	Maximum Sideload at full extension	Oil Capacity per Base Unit (cm ³)	
				Advance	Retract
50 (500)	156	SCJ-50	1,5%	1229	623
100 (1000)	156	SCJ-100	1,5%	2500	1400

Self-Locking Cube Jacks and Accessories

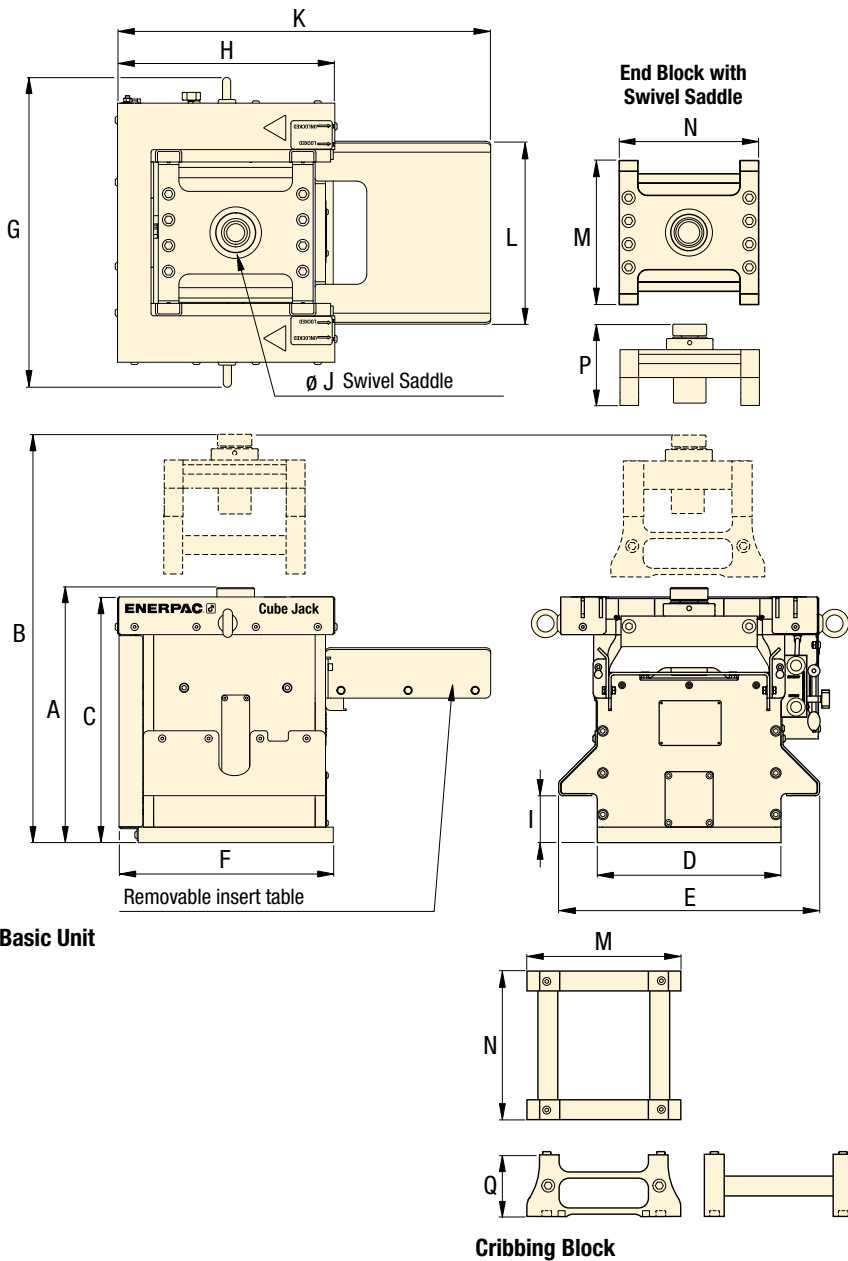

SCJ Series



Capacity Per Cube Jack:

500 - 1000 kN

Maximum Lifting Height:

2067 - 3006 mm

Maximum Operating Pressure:

700 bar

▼ SCJ-100 Self-Locking Cube Jack at maximum height of 3006 mm with 18 cribbing blocks.



Base Unit		End Block		Cribbing Block		Transport Frame *	
Model Number	(kg)	Model Number	(kg)	Model Number	(kg)	Model Number	(kg)
SCJ-50	360	SCJ5EB	40	SCJ5B	16	SCJ5F	110
SCJ-100	820	SCJ10EB	100	SCJ10B	23,5	SCJ10F	250

Dimensions (mm)																	Model Number
A	B	C	D	E	F	G	H	I	J	K	L	M	N	Min. P	Max. P	Q	
494	2067	476	356	505	443	556	428	91	125	726	351	300	310	175	225	125	SCJ-50
558	3006	526	506	655	636	772	598	101	170	1046	504	450	460	189	239	125	SCJ-100

* Dimensions Transport Frame L x W x H: **SCF5F:** 920 x 850 x 860 mm
SCF10F: 1600 x 1200 x 1500 mm

▼ Shown from left to right: SFP404SW and SFP613SW



- Smart valve technology allows both controlled lifting and lowering of multiple points
- 4, 6 or 8 split-flow outlets with equal oil flow
- Valve operation with advance/hold/retract function
- Remote pendant (24 V solenoid) control
- Oil flow per outlet from 0,45 to 1,30 l/min at 700 bar
- Pressure compensated flow control per circuit
- Adjustable pressure relief valve per circuit
- All models include pressure gauge per circuit.

▼ Typical set-up with 4 Self-Locking Cube Jacks and cribbing blocks to lift a transformer. Enerpac recommends to power the Cube Jack using SFP-Series Split-Flow Pump.



Multiple Outlets with Equal Oil Flow



Split-Flow Pumps

SFP-Series Pumps with multiple outlets with equal oil flow. For lifting and lowering applications on multiple points, Split-Flow Pumps are a far better alternative than using separately operated pumps.



Remote Control Pendant

Split-Flow pumps with solenoid valves include a remote pendant with selector switches for each individual outlet, allowing single or multiple cylinder operation.



Synchronous Lifting Systems

If synchronization is required, the Cube Jack can be used with any Enerpac Computer Controlled Synchronous Lifting System from the basic EVOB-Series up to 8 lifting points. For more than 8 lifting points Enerpac recommend the EVO-Series. See enerpac.com.

SFP-Series, Split-Flow Pumps

▼ HC-7206 Thermo-Plastic Hose



Thermo-Plastic Safety Hoses

- For demanding applications, featuring a 4:1 safety factor
- Max. working pressure 700 bar
- Outside jacket is polyurethane, to provide maximum abrasion resistance.

Thermo-Plastic Safety Hoses

Hose Internal Diameter (mm)	Hose End Assemblies with male half couplers		Hose Length (m)	Model Number	Weight (kg)
	End one	End two			
6,4	CH-604	CH-604	6,1	HC-7220C	3,1
			15,0	HC-7250C	7,0

SFP Series



Reservoir Capacity:

40 and 150 litres

Split-Flow Outlets:

4, 6 and 8 outlets

Flow at Rated Pressure:

0,45 to 1,30 l/min

Maximum Operating Pressure:

700 bar



Pump Cart

Easily tows pump around jobsite. Can be used with all models of Split-Flow pumps.

Dimensions (LxWxH): 1219 x 762 x 419 mm
Weight: 64 kg

Description	Model Nr.
Pump Cart	LHPC

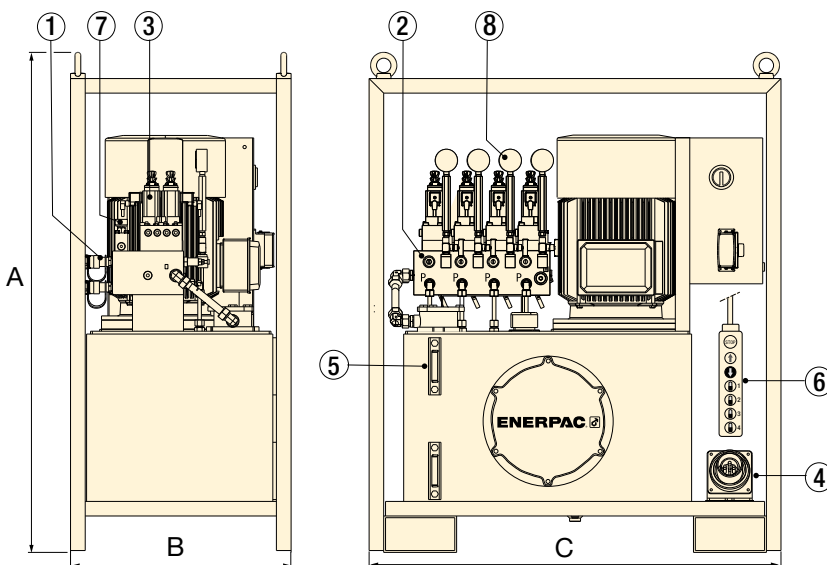

▲ SFP-Series with 150 litres reservoir (shown with 4 split-flow outlets)

- ① Manifold with split-flow outlets and CR-400 female half couplers
- ② Adjustable pressure relief valve per circuit
- ③ Solenoid 4/3 control valves (24 VDC)
- ④ Power receptacle
- ⑤ Oil sight gauge(s)
- ⑥ Remote control pendant with 5 m cord
- ⑦ Return flow control valve in each circuit
- ⑧ Hydraulic pressure gauge in each circuit

Split-Flow Pumps

Number of Split-Flow Outlets	Reservoir Size (litres)	Oil Flow per Outlet @ 700 bar (l/min)	Model Number * (400V, 3ph, 50Hz)	Motor Size (kW)	Dimensions (mm)			System Lifting Speed (m/hr)		
					A	B	C		(kg)	SCJ-50
4	40	0,45	SFP 404SW	5,5	1019	660	900	240	2,4	1,2
	150	0,90	SFP 409SW	5,5	1372	605	1130	476	4,5	2,2
6	40	0,45	SFP 604SW	5,5	1019	660	900	240	2,4	1,2
	150	1,30	SFP 613SW	11	1372	805	1200	551	6,0	3,0
8	150	1,30	SFP 813SW	15	1372	805	1200	591	6,0	3,0

* 4/3 Solenoid (24V) valve operation with Advance/Hold/Retract. With Remote Control Pendant.



LIFTING SYSTEMS

We design and manufacture heavy lifting equipment. For more than 60 years, we've combined high pressure hydraulics and controls to deliver intelligent and innovative solutions that maintain the highest level of quality, reliability and safety. We will be your supplier and partner; we will support you throughout the entire life of your project, your success is ours.

Heavy Lifting Technology



SFP-Series,
Split-Flow Pumps



EVOB-Series, Basic
Synchronous Lifting Systems



EVO-Series, Standard
Synchronous Lifting Systems



SCJ-Series,
Self-Locking Cube Jacks



JS-Series
Jack-Up Systems



SL, SBL-Series,
Telescopic Hydraulic Gantries



HSL-Series,
Strand Jack Systems



SHS, SHAS-Series,
Synchronous Hoisting Systems



LH, HSK-Series
Skidding Systems

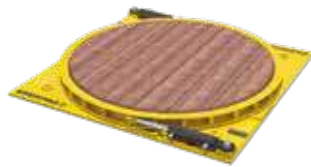

ETT-Series, Turntables



ETR-Series, Trolley Systems



SPMT-Series, Self-Propelled
Modular Trailers